

Supplement to

Specifications for Electrical Installations

Requirements for Parallel Generation Connected
to a National Grid owned EPS

Electric System Bulletin No. 756

December 2019, Version 5.0, 12/04/2019

(Supersedes all previous versions of ESB 756)



PREFACE

ESB 756-2018 references all requirements for parallel generation connected to National Grid facilities located in transmission jurisdictions in Upstate New York, Massachusetts, New Hampshire, Rhode Island, and Vermont and for distribution jurisdictions in Upstate New York, Massachusetts, and Rhode Island.

This supplement and its appendices are available on National Grid's website at <http://www.nationalgridus.com/electricalspecifications> and in printed form by contacting either of the National Grid Call Centers in Massachusetts or New York (see inside cover of ESB 750 for Customer Service Center telephone numbers). However, since printed copies may not reflect the latest updates, please refer to National Grid's website for the latest authorized versions.

TABLE of CONTENTS

SECTION	PAGE
TABLE of CONTENTS.....	3
1.0 INTRODUCTION	3
1.1 PURPOSE	3
1.2 SCOPE	3
1.3 GENERAL RULES, AND CODES, STANDARDS AND REFERENCES	3
1.4 DEFINITIONS.....	5
2.0 REVISION HISTORY.....	6
LIST OF APPENDICES TO ESB 756.....	6

1.0 INTRODUCTION

1.1 PURPOSE

The purpose of this National Grid Electric System Bulletin (ESB) is to:

1. Provide general requirements and recommendations for all generators connected in parallel with the electric power system (EPS) operated by National Grid (the “Company”). Stand-alone generators serving isolated load, which can never be connected in parallel with the Company’s EPS, are not subject to these requirements.
2. Ensure compliance with North American Reliability Corporation (NERC) Standard FAC-001-2 – Facility Interconnection Requirements, effective January 1, 2016. Along with all of the Company’s ESBs, the most current version of ESB 756 is available electronically at: www.nationalgridus.com/electricalspecifications.
3. Ensure that the electrical reliability and security of the Company’s EPS and the larger power system grid is maintained following connection of the parallel generator to the utility supply.
4. Refer Generator-Owners or Interconnection Customers (IC) to the applicable Federal Energy Regulatory Commission (FERC) or state-specific tariff regulations pertaining to parallel generators.

1.2 SCOPE

1. This ESB addresses FERC-jurisdictional interconnections, where the generator wishes to interconnect to:
 - A transmission system owned by National Grid that is administratively controlled by a regional independent system operator (“Regional ISO”);
 - A distribution or sub-transmission line owned by National Grid (which is presently interconnected to a third-party energy supplier or generating facility selling power into the wholesale market) for the purpose of selling power into the wholesale market.
2. This ESB also addresses state-specific requirements pertaining to parallel generators. These individual appendices are identified at the end of this document.

1.3 GENERAL RULES, AND CODES, STANDARDS AND REFERENCES

1. All new parallel generator installations require an interconnection study, performed by the Company at the customer’s expense, to determine site-specific requirements (*i.e.*, supply voltage, interconnection and service arrangement, location, and generation intent). Generation intent, in this context, refers to its end use being either: (1) total generator output energy for internal use, *i.e.*, peak shaving, (2) export sale, or (3) a combination. Additional

interconnection requirements for new generation connections to the 115 kV and above transmission system in New York, and 69 kV and above in transmission system in New England, shall conform with applicable requirements of the Regional ISO Tariffs, respectively. Note that the requirement to comply with such tariffs could apply at lower system voltage levels depending on whether the Generator-Owner or IC is selling power into the market.

2. For electrical specifications not covered by this document, the Customer shall refer to the Company's other ESBs, see www.nationalgridus.com/electricalspecifications.
3. Load Customers (end-user facilities) wishing to connect to the Company's transmission supply system should consult the Company's ESB 750 Series for Upstate New York, Massachusetts, New Hampshire and Rhode Island. In addition, the Company should be consulted for any questions not addressed by those documents.
4. Those wishing to establish "transmission facility interconnections" with National Grid's transmission supply system should consult the Company's Transmission Planning Department. Requirements for new transmission facility interconnections to the 115 kV and above transmission system in New York, and 69 kV and above transmission system in New England shall conform to applicable requirements of the NY or NE ISO Tariffs, respectively.
5. The Generator-Owner's or IC's facility shall conform to the latest revisions of all local, state and federal codes and national standards that apply; applicable Regional ISO; Northeast Power Coordinating Council, Inc. (NPCC), and NERC, FERC, or successor organizations associated with the operation of such systems or entities.
6. The Generator-Owner's or IC's facility shall also conform to any applicable requirements of state public utility regulatory commissions and any local, state, federal and/or other agencies from which a review, approval, or a permit is required.
7. These requirements govern the operation of generation in parallel with the Company's EPS. They concern only those points in which the Generator-Owner or IC and the Company have a mutual interest in the production facility's or premises' wiring service connection to ensure safety to the public and the Company's employees as well as satisfactory operation, compatibility, and reliability with the electrical supply to others served by the Company's EPS.
8. Regarding coordinated joint studies of new facilities and their impacts on the Company's interconnected transmission systems, the applicable Regional ISO, in accordance with the applicable sections of their respective tariffs, shall coordinate the conduct of any studies required to determine the impact of the Interconnection Request on Affected Systems with Affected Transmission Owners and, if possible, include those results (if available) in its applicable interconnection study within the time frame specified in these procedures. The Regional ISO will include such Affected Transmission Entities in all meetings held with the IC as specified in the applicable Regional ISO Tariffs. Notification of new or modified facilities by Generator-Owners or ICs to the Company and other parties responsible for the reliability of the interconnected transmission systems will occur as soon as feasible by the Regional ISO.
9. The voltage level, and MW and MVAR capacity or demand at the point of connection, shall be addressed in a System Impact Study to be performed by the Company, which shall:
 - a. Consist of a short circuit analysis; a stability analysis; a power flow analysis; voltage drop and flicker studies; protection and set point coordination studies; and grounding reviews, as necessary.
 - b. State the assumptions upon which it is based, state the results of the analyses, and provide the requirement or potential impediments to providing the requested interconnection service, including a preliminary indication of the cost and length of time

that would be necessary to correct any problems identified in those analyses and implement the interconnection.

- c. Provide a list of facilities that are required as a result of the Interconnection Request and non-binding good faith estimates of cost responsibility and time to construct.
10. Distribution System impact studies shall incorporate a distribution load flow study, an analysis of equipment interrupting ratings, protection coordination study, voltage drop and flicker studies, protection and set point coordination studies, grounding reviews, and the impact on electric system operation, as necessary.
11. Maintenance coordination and operational issues such as abnormal frequency and voltages shall be addressed by the applicable Regional ISO.
12. Inspection requirements for existing or new facilities, and communications and procedures during normal and emergency operating conditions, are addressed in ESB 755, "Operation and Maintenance Requirements For Services Above 600 Volts."
13. Any subsequent sale of generation ownership, which separates the generator from the remainder of a Customer's facility, requires the new Generator-Owner or IC to establish a separate interconnection for the generation.
14. Applicable national standards for parallel generator installations may include:
 - IEEE 519 "IEEE Recommended Practices and Requirements for Harmonic Control in Electrical Power Systems"
 - IEEE 1453 "IEEE Recommended Practice for the Analysis of Fluctuating Installations on Power Systems"
 - IEEE 1547 "IEEE Standard for Interconnection and Interoperability of Distributed Energy Resources with Associated Electric Power Systems Interfaces"
 - IEEE 1547.4 "IEEE Guide for Design, Operation, and Integration of Distributed Resource Island Systems with Electric Power Systems"
 - IEEE 2030.2 "IEEE Guide for the Interoperability of Energy Storage Systems Integrated with the Electric Power Infrastructure"
 - NFPA 850 "Recommended Practice for Fire Protection for Electrical Generating Plants and High Voltage Direct Current Converter Stations"
 - UL 1741 "Standard for Inverters, Converters, Controllers and Interconnection System Equipment for Use With Distributed Energy Resources"

1.4 DEFINITIONS

Company is National Grid

Company EPS refers to the electric power system owned, controlled, or operated by the Company and used to provide transmission or distribution services to its customers.

Generator interface point is the point of electrical connection of the parallel generator to the premise wiring.

Generator-Owner refers to any Non-Utility Generator even though they may also actually take electric service from the Company.

Interconnection Facility refers to those facilities necessary to effect the transfer of electricity from the parallel generator at the service point into the Company EPS.

Interconnection Point is where the interconnection facility connects to the Company EPS.

Interconnection System is the collection of all interconnection equipment and functions, taken as a group, used to interconnect a production facility to the Company EPS.

Islanding is generation serving utility load (or lines) without a synchronizing utility source connected.

ISO secured transmission system refers to delivery voltage systems as defined by the NPCC and controlled by a Regional ISO.

Parallel generator is defined as generation connected to a bus common with the Company EPS.

Production Facility refers to the Generator-Owners' or IC's (producers') parallel generator facilities. It shall include all facilities and equipment up to and including the Production Facility's high voltage side generator transformer disconnect or switches.

Wholesale Delivery Point shall mean the point on the Company EPS where the IC makes capacity and energy available, as indicated in the interconnection agreement entered into by the Company and the Generator-Owner or IC.

The terms Customer, distributed generator (DG), distributed resource (DR), distributed energy resource (DER), interconnection customer (IC), and isolation are defined in the Company's jurisdiction applicable tariffs.

2.0 REVISION HISTORY

Version	Date	Description of Revision
1.0	06/01/07	Initial version of new document superseding all previous revisions of ESB 756.
1.1	09/06/11	September 2010 ESB 750 Series Errata changes.
2.0	05/11/12	Revised ESB 756 Appendix C and added version numbers to appendices.
2.1	08/22/12	Revised ESB 756 Appendix D.
2.2	09/22/14	Editorial to ESB 756 Appendix A and Revised ESB 756 Appendix B.
2.3	09/08/15	Revised ESB 756 Appendix C.
3.0	08/03/17	June 2017 major revision of Appendices A – D and deletion of E.
3.1	12/18/17	October-December 2017 interim amendments in Appendices A – D.
3.2	02/09/18	January-February 2018 interim amendments in Appendices B – D.
4.0	06/29/18	June 2018 annual revision of Appendices A – D and for IEEE 1547-2018 and updated National Grid practices.
5.0	12/04/19	December 2019 revised for updated National Grid practices.

LIST OF APPENDICES TO ESB 756

APPENDIX A: Requirements For Parallel Generation Connected to National Grid Facilities in New York, Massachusetts, Rhode Island, New Hampshire, and Vermont Not Applicable to State Regulatory Distributed Generator Interconnection Requirements, version 3.0

APPENDIX B: Distributed Generation Connected To National Grid Distribution Facilities Per The New York Standardized Interconnection Requirements, version 5.0

APPENDIX C: Distributed Generation Connected To National Grid Distribution Facilities Per The Massachusetts Standard for Interconnecting Distributed Generation, version 5.0

APPENDIX D: Distributed Generation Connected To National Grid Distribution Facilities Per The Rhode Island Standards for Connecting Distributed Generation, version 4.0

Electric System Bulletin No. 756 Appendix A:

**Requirements For Parallel Generation
Connected to National Grid Facilities in New York,
Massachusetts, Rhode Island, New Hampshire, and
Vermont Not Applicable to State Regulatory
Distributed Generator Interconnection Requirements**

Version 4.0, 12/04/2019

ESB 756 Appendix A is part of the ESB 750 series

TABLE of CONTENTS

<u>SECTION</u>	<u>PAGE</u>
TABLE of CONTENTS.....	2
PURPOSE	3
SCOPE	3
1.0 GENERAL.....	4
1.1 PERMITTED CONNECTIONS	4
1.1.1 Secondary Grid and Spot Network Areas.....	4
1.1.2 Phase Balance and Voltage Tolerance	5
1.2 ACCESS AND CONTACTS	5
1.3 DESIGN REQUIREMENTS	5
1.3.1 General Electrical Issues	5
1.3.2 Specific Electrical Issues.....	6
1.4 TYPES OF GENERATORS OR OTHER PARALLEL SOURCES	9
1.4.1 Induction	9
1.4.2 Synchronous	9
1.4.3 Inverter Systems	10
1.4.4 Energy Storage System (ESS).....	10
1.4.5 Microgrids	11
1.5 LIMITATIONS	12
1.5.1 All Generation	12
1.5.2 Special Situations	13
2.0 PROJECT MANAGEMENT	14
2.1 RESPONSIBILITIES	14
2.1.1 Generator-Owner or IC	14
2.1.2 Required Interconnection Study for Projects less than 69kV	16
2.1.3 Required Interconnection Study for Projects 69kV and Above in NY and in New England.....	17
2.1.4 No Agreement for Power Sales.....	17
2.1.5 Purchase of Generator-Owner’s or IC’s Power.....	17
2.1.6 Interconnection Agreement	17
2.2 COOPERATION	18
2.2.1 Overall Project	18
2.2.2 Notification and Initial Documentation	18
2.3 DEVELOPMENT OF AN INTERCONNECTION ARRANGEMENT	20
2.3.1 Initial	20
2.3.2 Project Scheduling	21
2.3.3 Generation Scheduling.....	21
2.4 COMPLIANCE	21
3.0 SERVICE INSTALLATION.....	22
3.1 SERVICE EQUIPMENT	22
3.2 GROUNDING	22
3.3 METERING	22
3.3.1 Metering Requirements in MA, NH, RI, and VT Jurisdictions.....	22
3.3.2 Metering Requirements in Upstate NY Jurisdiction	22
3.3.3 General Parallel Generation Requirements for Company Metering.....	22
4.0 PLANT REQUIREMENTS	23
4.1 TELEMETERING	23
4.1.1 Telemetry Criteria.....	23
4.1.2 Telemetry Specifications for Company-provided RTU	24
4.1.3 Telephone Installation Specifications for Company-provided RTU	25

TABLE of CONTENTS

<u>SECTION</u>	<u>PAGE</u>
4.2 TELECOMMUNICATIONS STEPS AND REQUIREMENTS	25
4.3 POWER QUALITY	25
4.4 PERFORMANCE/DESIGN.....	25
4.4.1 Generator Criteria	25
4.4.2 Step-up Transformer Specification	27
4.5 PLANT PROTECTION	27
4.5.1 Plant Protection Criteria	27
4.5.2 Automatic Switching and Protective Devices.....	28
4.5.3 Relay Settings and Testing	31
5.0 OPERATING.....	32
5.1 MANUAL DISCONNECT SWITCH	32
5.2 DISCONNECTION BY THE COMPANY (ISOLATION)	32
5.3 OTHER.....	32
6.0 REVISION HISTORY.....	33

PURPOSE

1. Electric System Bulletin (ESB) 756 Appendix A covers requirements for interconnecting generation facilities in parallel with National Grid’s (the “Company”) transmission and distribution electric power systems (EPS) where owned and operated in New York, Massachusetts, Rhode Island, New Hampshire, and Vermont.
2. ESB 756 Appendix A does not cover the New York State Standardized Interconnection Requirements and Application Process For New Distributed Generators 5 MW or Less Connected in Parallel with Utility Distribution Systems (NY SIR), or Massachusetts Standards for Interconnecting Distributed Generation (MA SIDG), or Rhode Island Standards for Connecting Distributed Generation (RI SCDG); see ESB 756 Appendix B, or Appendix C, or Appendix D, respectively.
3. This ESB supplements the Company’s ESB 750, Specifications for Electrical Installations, and various technical federal and state transmission operator jurisdictional requirements (FERC (Federal Energy Regulatory Commission), NYISO (New York Independent System Operator), and ISO-NE (New England Independent System Operator)) to provide general requirements, recommendations, and assistance to customers (i.e., Generator-Owners or Interconnection Customers (IC)) regarding generator facility systems connected in parallel to the Company’s EPS.
4. ESB 756 and this Appendix A are available on the Company’s website at <http://www.nationalgridus.com/electricalspecifications> and in printed form by contacting either of the Company’s Call Centers in Massachusetts or New York (see inside cover of ESB 750 for Customer Service Center telephone numbers). However, since printed copies may not reflect the latest updates, please refer to the Company’s website for the latest authorized versions.

SCOPE

1. This Appendix A to ESB 756 is provided to assist a Generator-Owner or IC desiring to interconnect a generator facility to National Grid’s EPS to meet requirements of all generating interfacing equipment to be designed, installed, interconnected, tested, and operated in accordance with applicable government, industry, and Company standards.
2. These requirements are limited to only those points in which the Generator-Owner or IC and the Company have a mutual interest in the production facility’s or premises’ wiring service

connection to ensure safety to the public and the Company's employees as well as satisfactory operation, compatibility, and reliability with the electrical supply to others served by the Company's EPS. This includes, but is not limited to,

- the location of the service point and facilities under the Company's exclusive control, such as the Company's metering to be installed at any point on either side of the service point;
- service lateral;
- service equipment; and
- the Company's need to automatically isolate parallel sources of the generator facility from the EPS should there be an unacceptable disturbance, event, or condition within the facility.

Conditions of electric service are based on governmental laws or regulations that determine the Company's authority to provide electric service under their respective jurisdictional electricity tariffs. See 90.2(B)(5) in the National Electrical Code® (NEC) and the Company's ESB 750 for more information.

3. These requirements pertain to those types of parallel generation that include merchant power plants, independent power producers (IPP), on-site generators (OSG), and energy storage systems (ESS) including distributed generators (DG) or distributed energy resources (DER), ESS, and microgrids not covered by retail interconnection tariffs, and where DER providers, or DER providers through DER aggregators, sign onto the wholesale or retail tariff with the intent to sell energy or ancillary services to the wholesale or retail generation markets. For wholesale tariff requirements, please refer to the following regional independent system operator ("Regional ISO") websites for the applicable jurisdiction:

NY:

[http://www.nyiso.com/public/markets_operations/services/planning/documents/index.jsp?docs=int erconnection-studies/other-interconnection-documents](http://www.nyiso.com/public/markets_operations/services/planning/documents/index.jsp?docs=int%20erconnection-studies/other-interconnection-documents),

http://www.nyiso.com/public/markets_operations/documents/technical_bulletins/index.jsp, and

http://www.nyiso.com/public/markets_operations/documents/manuals_guides/index.jsp

MA, NH, RI, & VT: <https://www.iso-ne.com/system-planning/system-plans-studies> and

<https://www.iso-ne.com/participate/rules-procedures/operating-procedures/?load.more=1>

4. Where state jurisdictional requirements apply of the NY SIR, or MA SIDG, or RI SCDG, please refer to those retail tariff requirements at the Company's websites for the applicable jurisdiction:

NY: https://www9.nationalgridus.com/niagaramohawk/business/energyeff/4_app-pkg.asp

MA: https://www9.nationalgridus.com/masselectric/home/energyeff/4_interconnection-process.asp

RI: http://www9.nationalgridus.com/narragansett/business/energyeff/4_interconnection-process.asp

5. These requirements may also be applied, at the discretion of the Company, to other methods used to generate electricity in parallel with the Company's EPS not ordinarily encountered or are not covered by any other regulated requirements, including but not limited to stored energy, regenerative drives used in elevators, and component power inverters used in exercise equipment and any other micro scale type of energy recapture systems.

1.0 GENERAL

1.1 Permitted Connections

The Company may be able to eliminate the need for a specific study in instances of the basis of the available systems. The Company shall determine the suitability of a given generator connection and its interconnection voltage.

1.1.1 Secondary Grid and Spot Network Areas

For specific technical requirements of parallel generation in secondary grid and spot network distribution systems, see the Company's ESB 756 Appendices B, C, and D. Additionally, the

Company's jurisdictional websites for interconnecting generator facilities in each state provide area maps locating the Company's secondary network service areas to assist the Generator-Owner or IC in determining if the proposed location is served by a distribution secondary network system.

1.1.2 Phase Balance and Voltage Tolerance

The Generator-Owner's or IC's generator facility shall permit equal current in each phase conductor at the service point or point of common coupling (PCC). Voltage unbalance resulting from unbalanced currents shall not exceed 2% and shall not cause objectionable effects upon or interfere with the operation of the Company EPS facilities and service to others. This design and operating criterion shall be met with and without generation in the Generator-Owner's or IC's generator facility.

The interconnection of the Generator-Owner's or IC's generator facility shall not affect the Company's nominal voltage delivery at the PCC by greater than 3% unless directed by the Company's transmission system operator or Regional ISO. Generator-Owners or ICs proposing parallel generator facility installations must consider that the Company's distribution EPS in rural locations will likely have single-phase loads on feeders that inherently have some unbalance on the main three-phase lines. The Company will specify conditions where volt-VAR control will apply.

1.2 Access and Contacts

1. Authorized Company employees, equipment, and vehicles shall have access to the Generator-Owner or IC facilities and Company's metering equipment at any time without delay.
2. The Generator-Owner or IC shall provide information identifying their contact person(s), addresses and their associated telephone number(s) to the Company.
3. Changes to phone numbers, points of contact, etc., shall be communicated in advance of the actual change with the effective date of change so indicated.
4. The Company will provide the Generator-Owner or IC with phone numbers for the appropriate Company contact(s). (Typically the jurisdictional Customer Service Center for generator facilities interconnected on 15kV or less systems and the jurisdictional distribution system Control Center for large generator facilities interconnected on 15kV and less systems that are wholesale registered and all 1 MW or greater generator facilities interconnected on or above 15kV systems.) Note that 5 MW and above generator facilities in New England require registering information with the ISO-NE regardless of interconnecting voltage.
5. If the Generator-Owner or IC enters a generation market through a DER aggregator with the intent of being dispatched for energy or ancillary services, the Company shall be a party to day-ahead up to real-time dispatch communications to coordinate system interaction.

1.3 Design Requirements

1.3.1 General Electrical Issues

1. Parallel generator facilities connected to the EPS can cause a variety of system impacts including steady state and transient voltage changes, harmonic distortion, and increased fault current levels. Those located individually on higher capacity feeders or circuits may not cause very serious impacts whereas those located on weaker circuits, in aggregation or in special cases (such as lightly loaded networks) can significantly impact the Company's EPS. The interconnection of all parallel generator facilities requires safeguards for synchronization and back-feed situations. Further, from the electric system perspective, the challenges posed by any given parallel generator facility's connection do not diminish significantly with reduction in generator facility size. For this reason, each specific connection must be studied with respect to its size, its type, and the nature of the electric system at the

interconnection point. Typically, an interconnection study will be performed by the Company to determine if the proposed generation on the circuit results in any relay coordination, fault current, and/or voltage regulation problems. It is the intent of any Company study in accordance with jurisdictional regulatory requirements, when applicable, to avoid negative power system impacts by identifying the particular type of impact that will occur under normal and N-1 conditions and determining the required equipment upgrades that can be installed to mitigate the issue(s).

2. There is a wide range of potential issues associated with the interconnection of generator facilities to the Company's EPS including, but not limited to:
 - Impact on step voltage regulation equipment
 - Increased fault duty on the Company's EPS equipment¹
 - Interference with the operation of protection systems
 - Harmonic distortion contributions
 - Voltage flicker
 - Ground fault overvoltages
 - Risk of islanding
 - System restoration
 - Power system stability
 - System reinforcement
 - Metering
 - Arc flash
3. All parallel generation shall be designed to ensure:
 - Capability to synchronize with the Company's EPS,
 - Capability to separate from the Company's EPS upon loss of the Company source,
 - No degradation of the Company's EPS safety and reliability, and
 - All energy supplied to the Company's electrical system shall meet the Company's power quality and transmission system operator requirements.
4. The Generator-Owner or IC shall be responsible for on-going compliance with regulatory, code, and system design and operating changes pertaining to their installation. This work will be performed at the cost of the Generator-Owner or IC. The Company requires all electrical and physical design documents and submittals in this and related Company bulletins relative to interconnections above 600 volts to be prepared and sealed by a single State-licensed Professional Engineer in the state where the installation is made, who is retained by the Generator-Owner or IC for that purpose.

1.3.2 Specific Electrical Issues

The Company will determine the interconnect voltage and method of interconnection with the system as addressed in various portions of this ESB 756 and the Company's other published ESB's.

In general:

¹ *The Company's substations and circuit breakers are subject to fault duty limitations. Adding generation to the Company's EPS increases the amount of fault current imposed on substation(s) and equipment located on feeder(s). Exceeding fault duties of equipment and devices at substation(s) and on feeder(s) as a result of generator facilities will not be permitted and alternate methods of interconnection shall be explored or the replacement, at the expense of the Generator-Owner or IC, of "overduty" equipment and devices with those of appropriate ratings and in conformance with the Company's standard design where this limit has been reached (see also Section 3.2.2 in this ESB 756 Appendix A).*

1. The minimum interconnection required for all generation at or above 69kV in New York shall be a three-breaker ring bus, unless an exception is granted as noted below. Additional circuit breakers and alternate substation configurations may be required when interconnecting multiple generating units.

Generation interconnecting to facilities operated at 200kV or less, or to radial transmission lines greater than 200kV, may be granted an exception and allowed to connect with a single circuit breaker or circuit switcher. These exceptions shall be evaluated on a case-by-case basis and shall be granted only when the following conditions are met:

- Protection Engineering verifies that the transmission line and interconnection facilities can be protected adequately, while ensuring that transmission system protective relay coordination and relay sensitivity can be maintained
- Transmission Planning verifies that transmission reliability is not adversely impacted by assessing the Design Criteria listed in Section 5.2 pertaining to safety, planning and operating criteria, reliability, and maintainability
- As deemed necessary by Transmission Planning, provisions acceptable to National Grid are made to accommodate the future expansion of the interconnection to (at least) a three-breaker ring bus

2. For generators interconnecting to New England Pooled Transmission Facilities (PTF), which are under ISO-NE jurisdiction, the guidance in ISO-NE Planning Procedure 5-6 Appendix A shall be followed.

The minimum interconnection required for all generation shall be a three-breaker ring bus, unless an exception is granted for any of the conditions noted below. Additional circuit breakers and alternate substation configurations may be required when interconnecting multiple generating units.

Generation may be granted an exception, and allowed to connect with a single circuit breaker or circuit switcher, subject to acceptable evaluations noted below, for any of the following conditions:

- 1) Generation connected to a radial transmission line. A radial transmission line is defined as a transmission line that emanates from a single station with one or more breakers that are capable of switching the transmission line in and out of service. Note that a radial tap from a network transmission line is part of that network transmission line.
- 2) Generation connected to a tap from a radial transmission line
- 3) Generation no larger than 20 MW connected to:
 - a. A network transmission line
 - b. An existing tap from a network transmission line
 - c. A dedicated distribution circuit(s), tapped from a network transmission line via a step-up transformer, with no retail load served on the circuit(s).

Note regarding exception #3: Incremental generation additions at an existing substation (at either transmission or distribution voltage), which result in greater than a 20 MW total generation at that substation, with no retail load served on the circuit(s), shall trigger the minimum three-breaker ring bus requirement.

- 4) Generation connected to existing distribution circuits or systems serving existing load
These exceptions shall be evaluated on a case-by-case basis and shall be granted only when the following conditions are met:

- Protection Engineering verifies that the transmission line and interconnection facilities can be protected adequately, while ensuring that transmission system protective relay coordination and relay sensitivity can be maintained
- Transmission Planning verifies that transmission reliability is not adversely impacted by assessing the Design Criteria listed in Section 5.2 pertaining to safety, planning and operating criteria, reliability, and maintainability
- 3. As deemed necessary by Transmission Planning, provisions acceptable to National Grid are made to accommodate the future expansion of the interconnection to (at least) a three-breaker ring bus. The preferred interconnection at 23kV up to 46kV is a radial line(s) to a station. Other interconnection alternatives may require installation of a Company three-breaker station.
- 4. For 69kV and above systems upon written request of the Generator-Owner or IC and execution of a Study Agreement, the Company will investigate the feasibility of a tap only for small generator facilities defined in the FERC Small Generator Interconnection Procedures² (SGIP) in the course of conducting the Feasibility Study. This investigative effort will be added to the Feasibility Study and will proceed as follows:
 - 1) To adhere to regulatory timeline requirements, the Company will inform the Regional ISO and the Generator-Owner or IC at the scoping meeting that the three-breaker station will be assumed as the “initial” interconnection to be evaluated in the Feasibility Study’s power flow analyses.
 - 2) The Company will also indicate that as the Feasibility Study’s power flow analyses are underway, a protection engineering analysis will review the feasibility of a tap.
 - 3) If a tap is deemed feasible, the tap configuration will be adopted going forward in the System Reliability Impact Study (SRIS) and Facility Study.
 - 4) If a tap appears not to be feasible or when the Generator-Owner or IC waives a Feasibility Study to proceed directly to a SRIS and Facility Study, then the three-breaker station configuration will be used going forward in the SRIS and Facility Study.
 - 5) Engineering cost estimates will be provided for the system upgrade facilities (SUF) associated with either the tap or the three breaker station.
 - 6) The Generator-Owner or IC will be required to install an interrupting device (e.g. breaker or circuit switcher) at the high side of their generator facility’s generator step-up (GSU) transformer.
 - 7) The Study Agreement’s matrix scope may need to be modified to accommodate the need for a possible tap feasibility review prior to the Generator-Owner or IC and the Company executing either the Feasibility Study or SRIS and Facility Study to begin.
- 5. The Company transmission system required to accommodate the generation interconnection shall be designed and installed to the Company’s standards and practices, under the review and approval of the Company.
- 6. Regardless of interconnection voltage, protection schemes and connection arrangements shall be designed to prevent islanding of the generation with a portion of the Company’s supply to other customers.
- 7. The Company reserves the right to review and approve the ratings and parameters of major electrical equipment supplied by the Generator-Owner or IC, such as, but not limited to: GSU transformers, interrupting devices, relays, and the generator facility with its associated systems. For the purposes of this ESB Appendix A, any reference to generator ratings herein refers to the nameplate rating of the generator facility.

² See <https://energy.gov/savings/interconnection-standards-small-generators> and for descriptions of the named studies and agreements.

- For inverter-based generation, this shall refer to the nameplate rating of the inverter(s). De-rating of inverter-based generators shall only be considered if the equipment is provided by the Generator-Owner's or IC's manufacturer with a permanent means of reducing the rated output, and so marked with an equipment nameplate stating the de-rated output.
 - For rotating machines, this shall refer to the nameplate rating of the generator (as opposed to the nameplate rating of the generator-set). De-rating of rotating machine generators by their prime mover capabilities shall not be permitted.
 - Equipment nameplates shall meet American National Standards Institute (ANSI) standards. De-rating of generator facility equipment shall be evaluated on a case-by-case basis, with consideration given to specific project conditions, and may be accepted at the sole discretion of the Company.
8. The Generator-Owner or IC is solely responsible for the protection of their plant equipment. The Generator-Owner or IC is required to provide electrical equipment and relays with ranges and ratings that will allow proper Generator-Owner or IC relay system coordination with the Company's protective relay systems. Coordination margins and parameters will be determined by the Company.
9. The Generator-Owner or IC is responsible for the coordination of any Generator-Owner or IC applied over and under frequency or over and under voltage generator tripping with Company specified requirements. The generator facility is expected to remain on line and fully operational following a system excursion within specified parameters. The correct performance of the generator facility's frequency protection relays is critical to system security. Consequently each Generator-Owner or IC will be required to both recalibrate their frequency protection and provide the Company this relay performance documentation. Maintenance coordination and operational issues such as abnormal frequency and voltages shall be addressed by the applicable Regional ISO.

1.4 Types of Generators or Other Parallel Sources

1.4.1 Induction

1. Reactive power supply for induction generators poses difficult design problems, depending on the generator size.
2. Induction generation over 50kVA require capacitors to be installed by the Generator-Owner or IC. The determination of the size and location of the capacitors shall be proposed by the Generator-Owner or IC and reviewed for acceptance by the Company as part of the System Impact Study. The installation of capacitors at or near an induction generator can cause it to become self-excited, if disconnected from the Company EPS. The additional expense for special protective equipment may favor the use synchronous machines.
3. Starting or rapid load fluctuations on induction generators can adversely impact the Company's EPS voltage. Corrective step-switched capacitors or other techniques may be necessary. These measures can, in turn, cause ferroresonance. Across the line starting of induction motors/generators will be permitted only where inrush current and voltage will not exceed allowable motor start inrush limits and the Company's flicker criteria.
4. Otherwise, protection for induction generation is similar to synchronous generation. Although, doubly-fed induction generators have a different protection scheme a squirrel cage induction generation may be treated as synchronous generator. Synchronizing relays may not be required, but a contact-making tachometer set at synchronous speed may be required.

1.4.2 Synchronous

For synchronous generators, sufficient generator reactive power capability shall be provided to withstand normal voltage changes on the Company EPS. The generator voltage-VAR schedule, voltage regulator, and transformer ratio settings will be jointly determined by the

Company and the Generator-Owner or IC to ensure proper coordination of voltages and regulator action. For North American Reliability Corporation (NERC) Standard VAR-001 requirements applicable to a Generator-Owner's or IC's generator facility, the Company will direct the Generator-Owner or IC to have an Automatic Voltage Regulator and Control system to operate in automatic voltage control mode, which will be at a voltage set point provided by the Company to maintain EPS voltages.

1.4.3 Inverter Systems

Direct current generators can only be paralleled with the Company EPS using a synchronous inverter. The design shall be such as to remove this synchronous inverter upon a utility system interruption. Proper harmonic filtering is necessary for inverter systems to minimize harmonic distortion from being introduced into the EPS. Normally these filters are inside the inverters. DG Customers proposing inverter systems shall demonstrate compliance with the Institute of Electrical and Electronics Engineers (IEEE) Standard 1547 with the proposed inverter system being certified and listed as having been successfully tested by a Nationally Recognized Testing Laboratory utilizing Underwriters Laboratories (UL) Standard 1741. Systems that do not utilize such listed inverters shall be required to provide alternate protective relaying systems which provide utility system fault detection and disconnection subject to the Company's review and acceptance.

1.4.4 Energy Storage System (ESS)

Various types of ESS may be considered that connect in parallel to the Company's EPS.

Battery storage is common for DER applications where the primary benefit enables DG sources to be dispatched / adjusted upon request behind the meter (BTM). In these cases, the ESS is charged by the DG system to be available later to dispatch the stored energy when the DG facility is not generating. Customers may apply battery storage where there is no DG facility to take electricity from the Company's EPS as a load during off-peak times when rates are lower, store the electricity, and then use the BTM stored electricity during peak times when rates are higher.

ESS clearly has the potential for significant effect on the load flow of the area EPS and the overall dispatch characteristics of the network. An ESS can be complemented by "smart inverter" technology at the PCC, which could also affect the EPS. Under such circumstances, it is critical to understand the operating characteristics of the ESS, including import and export times, as well as equipment power ratings and capabilities. Additional information may be required at the time of application for interconnection such as:

- Method of ESS connection whether: (1) ESS directly connected to the Company's EPS; (2) DG and ESS DC coupled; (3) DG and ESS AC coupled; (4) ESS on utility line side of service point and revenue meter; and (5) ESS on load side of service point and utility revenue meter with the premises load, as applicable to the proposal.
- Sequence of operation for the charging and discharging capabilities of the ESS and the maximum ramp rate in Watts/second.
- Non-UL 1741 listed inverters will require a utility grade intertie relay with the appropriate IEEE 1547 functions, settings, and islanding protection according to the Company's [ESB 756](#) jurisdictional requirements.
- Service configuration and revenue metering provisions shall meet the Company's [ESB 750](#) and its applicable supplements.

1.4.5 Microgrids

Various types of microgrids³ may be considered that connect in parallel to the Company's EPS. The U.S. Department of Energy (DOE) defines a microgrid as "[a] group of interconnected loads and distributed energy resources (DER) with clearly defined electrical boundaries that acts as a single controllable entity with respect to the grid [and can] connect and disconnect from the grid to enable it to operate in both grid connected and island mode."⁴ Microgrids may be particularly appropriate to address resiliency and reliability (*i.e.*, ability to island in the event of an EPS outage). The Company's position⁵ is that when a community microgrid serves multiple customers (in contrast to a facility or campus-style microgrid serving a single customer such as a university or a hospital), including residential customers, and operates within the surrounding electric distribution infrastructure, the Company is in the best position to own and properly operate electric distribution facilities within the community microgrid for the public interest in terms of safety, reliability, and resiliency.⁶

Facility or Campus-style Microgrid PCC to EPS

Facility or campus-style microgrids have certain characteristics described here, all of which fall under the DOE definition. Such microgrids consist of one or more buildings and the relationship with the connection to the Company's EPS is characterized as either a single customer-of-record or a single operating entity on one property. These can take several forms such as:

- 1) A single building under a common property owner with a common customer account. The microgrid has generation resources that can operate in parallel with the electric grid or in island mode.
- 2) A single building under a common property owner/customer, with multiple direct-metered accounts. The microgrid is configured so that all customers within the building can share the benefits of DER.
- 3) Multiple buildings owned by a common property owner where microgrid loads and DER are tied with common electric distribution facilities generally not owned by the Company.

These facility or campus-style microgrids are premises wiring systems governed by the NEC as adopted by the local jurisdictional authority.⁷

Community Microgrid PCC to EPS

A "community microgrid" is one that involves a combination of customers from large commercial and industrial to single residential customers with the following characteristics where the Company exclusively controls the electric distribution facilities within the community microgrid.

- 1) Consist of more than one building and more than one customer on multiple properties in relationship with the service from the Company and containing generation resources that operate in parallel with the Company's EPS during normal operation but are designed to

³ See IEEE 1547.4-2011, Guide for Design, Operation, and Integration of Distributed Resource Island Systems with Electric Power Systems, at Section 4.3, for examples of electrical configurations of microgrids; available at http://grouper.ieee.org/groups/scc21/1547.4/1547.4_index.html.

⁴ See Case 14-M-0101, Proceeding on Motion of the Commission in Regard to Reforming the Energy Vision ("REV Proceeding"), Order Adopting Regulatory Policy Framework and Implementation Plan (issued February 26, 2015) ("REV Track One Order"), p. 109, where the Commission adopts the DOE definition for its purposes as well.

⁵ The Company shares the same position with other utilities in New York ("New York Joint Utilities" or "NY JU").

⁶ See REV Proceeding, Joint Utilities' Response to Notice Soliciting Comments on Microgrids (filed May 1, 2015), p. 6.

⁷ See NFPA 70-2017, NEC, for installation requirements of premises wiring systems related to microgrids.

operate detached from the Company's EPS in "island mode" whether the source of power during islanding is DER or qualifying facilities ("QFs"), or a combination of DER and QFs.⁸

- 2) The multiple buildings and multiple customers on multiple properties are connected only through the Company's electric distribution facilities. This means there are no common customer-owned electric distribution facilities or common property ownership.

The Company emphasizes the importance of the compliance of all microgrids with the safety requirements of applicable codes. The utility electric distribution facilities connecting participants and users in community microgrids are delivery systems governed by the National Electrical Safety Code® (NESC)⁹ as adopted by the local jurisdictional authority. The individual customers connected to the community microgrid through the utility's electric distribution facilities have premises wiring systems that are governed by both the NEC, as adopted by the local jurisdictional authority, and the Company's own electric service rules for the safety of users from the hazards of electricity.

The Company must be able to control the isolation of a community microgrid at each PCC if the Company is to be held accountable for the safety and reliability of service within such a microgrid. This isolation can be achieved by visible break disconnect switches, interrupting devices or a combination thereof which can be manually or remotely operated by the Company. DER and QFs, if any, may be permitted to automatically trip a microgrid PCC isolation device in order to island the community microgrid; however, they should be blocked from closing such a device until authorized to do so by the Company's control center. The control scheme that will disconnect and reconnect the community microgrid from the Company's EPS must be reviewed and approved by the Company through an interconnection study (and subsequently memorialized in an interconnection agreement among the parties) and may be subject to witness testing and/or periodic testing as necessary. Other scenarios that may be permitted will each have their own complexities. As such, each community microgrid will require that specific protocols be developed to ensure that customer safety and the overall EPS safety and reliability are not in any way compromised.

Variations of proposed community microgrids from these described in this ESB 756 Appendix A will require prior regulatory and Company review.

Common Microgrid PCC Requirements

DER interconnection equipment, protective systems and microgrid controllers at the PCC to the Company's EPS are to be designed and operated according to the Company's requirements and specifications as well as to applicable codes and industry standards. These assets may be owned and operated by customers or third parties. Individual DER facility interconnections subject to specific jurisdiction-applicable electricity tariffs shall comply with those requirements for connecting to the Company's EPS in a microgrid.

1.5 Limitations

1.5.1 All Generation

1. The Company permits the operation of generating facilities in parallel with the Company's EPS, whenever this can be done without adverse effects on the general public, the Company's personnel, and the Company's equipment, in accordance with all applicable laws and regulations. Certain protective devices (relays, circuit breakers, etc.) where

⁸ See IEEE 1547.4-2011, *supra* n. 7 where community microgrids will only operate in island mode for reliability purposes during system emergencies (e.g., storm outages) or to address a temporary electric grid supply deficit. If the community microgrid is otherwise intended, allowed or encouraged to operate in an island mode for other reasons (e.g., economic), such scenarios should be taken into consideration both when designing the community microgrid, particularly given the complexities of resulting controls schemes, and when drafting the transactional agreements among participants.

⁹ See ANSI/IEEE C2-2017, NESC, for installation requirements of utility supply and generation systems related to microgrids.

specified by the Company shall be installed at any location where the Generator-Owner or IC desires to operate generation facilities in parallel with the Company's EPS. These devices promptly disconnect the Generator-Owner's or IC's generation facilities from the Company's EPS whenever faults or abnormal conditions occur.

2. For DER 50 kW or above (standalone or in aggregate), the Company may limit the operation, or disconnect, or require the disconnection of the DER from a distribution or transmission EPS at any time, with or without notice, in the event of real or predicted abnormal operating conditions, so that the safety and reliability of the EPS is preserved. For planned and scheduled maintenance events, prior notice (typically 48 hours in advance) will be provided by the Company whenever possible.
3. In order to maintain a safe and reliable system, the utility needs to be informed of the current and forecasted operating status of a DER. DER sized 50 kW or greater (standalone or an aggregate) shall notify the utility when disconnecting/reconnecting to the distribution system, regardless of enrollment in any Regional ISO-administered wholesale generation markets. The following are some of the issues considered before accepting generation:
 - 1) Proximity to the Company's circuits.
 - 2) Generation capacity and the load on the Company's circuits during light load conditions.
 - 3) Review of voltage profiles and system thermal limitations provided by the Company's system electric studies.
 - 4) System protection coordination with the proposed generation and prevention of the generator from "islanding."
 - 5) Impact of prime mover.
 - 6) Generator-Owner's or IC's facility ratio of generation to light load.
 - 7) DG saturation on distribution circuits (see ESB 756 Appendices B, C, and D).
4. From the above, the Company will determine the voltage, interrupting ratings, type of equipment and controls needed for proper protection coordination. The Company reserves the right to determine the Generator-Owner's or IC's interconnection voltage.
5. The Company reserves the right to have the Generator-Owner or IC remove their generation from the EPS at any time upon the Company's request. Normally, such requests result from the need to facilitate maintenance, testing, repairs, and emergency restoration or safety concerns related to the Company's EPS.

1.5.2 Special Situations

Under this bulletin, the Company restricts Generator-Owner or IC connection to the following situations.

1.5.2.1 Net Generation Output

The Company reserves the right to limit generation to its facilities operating to that level which will not compromise safety, reliability, or protection margins. Due to the many variable parameters involved, special requirements for any proposed net generation levels will be determined by the Company on a site specific basis. Export of surplus energy will require a power purchase agreement (PPA) between the Generator-Owner or IC and the Company in accordance with the applicable tariff provisions depending on whether such export is FERC jurisdictional or state jurisdictional.

1.5.2.2 Peak Shaving Generation

1. Arrangements for standby or supplemental energy needs are addressed by the Company's filed jurisdictional tariffs and shall be made prior to actual need to ensure its availability.
2. Peak shaving generation is customer-owned generator facilities operated in parallel with the Company's EPS to reduce a customer's electrical demand.

- Peak shaving parallel generator installations, if not authorized under BTM Regional ISO programs, shall not be allowed to supply any net generation into the Company's EPS and will require the installation of protection devices (e.g., reverse power relays) to limit such power export onto the Company's EPS. The Company's revenue metering shall be detented in this case to prevent reverse billing meter registration. Where the Company is requested to supply demand pulse information (either analog or digital), its use is not intended for generator control.
- Where PPAs, net energy metering (NEM), or BTM services apply, a peak shaving generator facility may be permitted to export into the Company's EPS under the requirements of this ESB 756 Appendix A.

2.0 PROJECT MANAGEMENT

2.1 Responsibilities

2.1.1 Generator-Owner or IC

1. No generation, no matter its intent, shall be installed or operated in parallel with the Company's EPS without prior notification to and approval by the Company.
2. This responsibility applies to an initial generator facility, as well as to subsequent additions and/or modifications of Generator-Owner or IC equipment. Any subsequent sale of any generator facility covered by the requirements of the jurisdiction-applicable tariff will require the new owner to establish a separate interconnection agreement for the generation with the Company and comply with current parallel generation requirements. The Generator-Owner or IC is responsible for modifying their system to comply with any future mandate of the Company, Regional ISO, NERC (NPCC), and NERC or successor organizations including costs incurred.
3. If the Generator-Owner or IC makes significant changes in the design or scheduling of the generator facility, then any previous information furnished by the Company to the Generator-Owner or IC shall be subject to review and possible change. Failure to communicate such changes to the Company may result in delay of interconnection service or termination of interconnection service by the Company.
4. The Generator-Owner or IC is responsible for performing all operating functions associated with their equipment and for maintaining all equipment under their ownership. The Generator-Owner or IC shall arrange to have trained personnel available for the proper and safe operation of their equipment. The Generator-Owner or IC shall follow the Company's specified switching protocol upon commissioning, synchronizing, and return-to-service situations with the Company's transmission or distribution system operator; see ESB 755 for more information.
5. The Generator-Owner or IC shall provide proper and continuous maintenance of all plant facilities; refer to ESB 755 and National Fire Protection Association (NFPA) 70B (and NFPA 73 where applicable) and other nationally recognized industry standards for guidance on electric equipment maintenance.
6. The Company will specify telecommunication services as required for the installation. See Section 4.2 for data submittal to the local telephone company.
7. For the Company-owned RTU installation in NY, the Generator-Owner or IC shall arrange to provide the necessary telecommunication service as specified by the Company. As this process typically takes several months, the Generator-Owner or IC is responsible for submitting the information to their local telephone company, see Section 4.2, in a timely fashion. The Company will not be liable for the results of any delays.
8. The Generator-Owner's or IC's telephone number(s) shall allow for 24-hour per day contact of either a staffed control room or delegated operating agent.

9. If the Generator-Owner or IC is in part or whole selling energy or ancillary service directly to a wholesale generation market or aggregator, all dispatch signals shall be communicated to the Company's Control Center (day ahead up to and including real time). The communication of these dispatch signals shall be compatible with Company communication systems.
10. The Generator-Owner's or IC's backup service requirements from the Company's EPS shall be requested using the prescribed forms in the Company's jurisdictional tariffs.
11. Application Process:
 1. Parallel operation of a generator facility becomes integrated with the Company's EPS whereby the Generator-Owner or IC and the Company have a mutual interest in ensuring that the interconnection meets the required electrical reliability and security of the Company's EPS. This is necessary to ensure safety to the public and to Company employees and satisfactory operation, compatibility, and reliability with the electrical supply to other customers. The steps and timing requirements of the application process are identified within the jurisdiction-applicable regulatory requirements; see Scope section at the beginning of this document. The time required to complete the application process, however, may depend on the characteristics of the generator facility's system, the size class, its intended operating modes, and the characteristics of the Company's EPS at the point of interconnection (POI).
 2. For new electric service or modifications to the electric service connection to accommodate the Generator-Owner's or IC's parallel generator facility, refer to the Company's latest revision of ESB No. 750, Specifications for Electrical Installations and its applicable supplements. The Generator-Owner or IC will be responsible for any permitting and conformance to the latest revision of all local, state and federal codes and national standards that apply. The Generator-Owner or IC will also be responsible for any additional costs associated with work completed by another entity (such as telephone company pole sets) and should be aware that project construction schedules can be significantly impacted by this other work.
 3. When considering a new or modified generator facility interconnection arrangement, the jurisdiction-applicable tariff forms are required to be submitted to the Company.
 4. The application process and attendant services are offered by the Company on a non-discriminatory basis to any Generator-Owner or IC and as a part, the Company may identify the need for detailed engineering studies, EPS upgrades, and additional protection requirements. As allowed by the jurisdiction-applicable electricity tariff, the costs of the detailed study and upgrades are the responsibility of the Generator-Owner or IC. If the Generator-Owner or IC makes significant changes in the design or installation scheduling of their generator and interconnection facilities, then any previous information furnished by the Company to the Generator-Owner or IC is subject to review and possible change, which may cause a delay in service.
 5. Notice to the Company to install parallel generation shall be an application form from the jurisdiction-applicable electricity tariff, signed by the Company and the Generator-Owner or IC. This form shall include:
 - 1) Complete generator data sheets,
 - 2) The generation's intended purpose (*i.e.*, peak shaving or sale),
 - 3) Geographic location,
 - 4) Service point location (*i.e.*, circuit name and number, pole number, etc.),
 - 5) Contact information, name and telephone number of individual to be contacted regarding generator operation, and

- 6) A provision stating that it is the responsibility of the Generator-Owner or IC to notify the Company, in writing, to obtain and complete a new application form whenever information changes.
6. A Letter of Commitment shall accompany the completed application form and including:
 - 1) Result(s) of the Company's electric study,
 - 2) Written authorization from the Generator-Owner or IC for the Company to proceed with engineering and construction of the interconnection including initial payment.

12. Contributions

1. All costs incurred by the Company as a result of a Generator-Owner's or IC's facility, over the life of that facility, shall be reimbursed to the Company by the Generator-Owner or IC. The Company will advise the Generator-Owner or IC concerning any charges and payment schedules required.
2. All costs incurred by the Company for supply system changes, metering upgrades, and telemetering circuit changes associated with the Generator-Owner's or IC's installation shall be reimbursed to the Company by the Generator-Owner or IC. These costs also include initial engineering evaluations, purchase and installation of additional switching, transmission and distribution equipment at Company's facilities, additional safety provisions, engineering, and administration. The Company will notify the Generator-Owner or IC when these situations arise along with their associated charges and execute terms and conditions for payment. These costs shall be paid in full by the Generator-Owner or IC prior to commencement of service in accordance with the jurisdiction-applicable electricity tariff.

2.1.2 Required Interconnection Study for Projects less than 69kV

This study identifies the items of major cost to the interconnection. The scope of work is dependent upon the size and electrical location of the project. The study's primary function is to assess the impact the proposed project has upon the operation of the existing EPS and addresses the following principle areas:

2.1.2.1 Thermal margins

An assessment is made to ensure that the proposed project will not overload lines or impose operational constraints on the existing system.

2.1.2.2 Voltage performance

An assessment is made to ensure the proposed project can operate within voltage guidelines. For voltages less than 69kV, the guidelines are +5/-10% of nominal.

2.1.2.3 Stability

An assessment is made to ensure that local clearing times are such that unit stability is maintained and regional stability is not negatively impacted. Power system stabilizers shall be installed when such controls are required to dampen system oscillations.

2.1.2.4 Short Circuit Studies

A study is performed to ensure that circuit breaker duties remain within nameplate ratings with the addition of the project.

2.1.2.5 Protection

In this study phase an initial assessment is made to define required changes to local protection.

2.1.2.6 Risk of Islanding

Where required, a study is made to determine if the generator facility may island the local EPS under certain minimum load to generation match conditions and to define required changes to local EPS protection.

2.1.2.7 REGIONAL ISO/NPCC/NERC

Compliance with the planning standards of Regional ISO/NPCC/NERC will be required for Regional ISO-controlled interconnections.

2.1.3 Required Interconnection Study for Projects 69kV and Above in NY and in New England

For 69kV in NY or in New England and above connections, the Generator-Owner or IC shall contact and obtain from the Regional ISO the requirements for an approved interconnection study. In this study phase an assessment will be made to ensure generation connected to the state jurisdictional secured transmission system complies with Regional ISO/NPCC/NERC or successor organization's planning standards in force at the time of energization of the Generator-Owner's or IC's facilities. Note that this could apply at lower system voltage levels if the Generator-Owner or IC is selling power into the generation market.

2.1.4 No Agreement for Power Sales

Generator-Owners or ICs who generate in parallel for the purpose of reducing their energy and demand utilization from the Company EPS (*i.e.*, peak shaving generation) are not required to have a power purchase agreement with the Company. However, they still shall comply with the requirements of this ESB Appendix A and the Company's jurisdiction-applicable electricity tariff, as determined by the Company. The Company on a case-by-case basis shall determine additional protective devices. The Generator-Owner or IC is required to complete all Company jurisdiction-applicable tariff forms relating to generators. The Company will advise the Generator-Owner or IC of any change of service class.

2.1.5 Purchase of Generator-Owner's or IC's Power

1. Company's Retail Tariff Service Option: The Company will advise the Generator-Owner or IC concerning a retail Service Class contract (*e.g.*, PPA) for any power purchased from the Generator-Owner or IC by the Company in accordance with the Company's jurisdiction-applicable filed electricity tariffs.
2. Wholesale Option - Direct Sale to the Regional ISO: The Generator-Owner or IC shall enter into an agreement with a Regional ISO for the sale of energy. This arrangement requires a separate agreement with the Company for the interconnection of the generating facility. Where the Generator-Owner's or IC's facility is a DER, they may commit the output to a third party DER aggregator in order to sell in the Regional ISO generation market (*i.e.*, direct sale or transacting with a third party engaged in sales to the Regional ISO). Under the aggregation model, the Generator-Owner or IC or DER Aggregator shall consult the Regional ISO for the applicable interconnection rules as well as FERC for any required filings.

2.1.6 Interconnection Agreement

1. A signed Interconnection Agreement along with any other completed generator-related jurisdictional tariff form(s) is required between a Generator-Owner or IC and the Company, and, if necessary, the Regional ISO. For generator facilities connected to distribution systems under Company jurisdiction-applicable electricity retail tariffs, see ESB 756 Appendices B, C, and D.
2. In general, the Interconnection Agreement will address the mutual acceptance of an interconnection study, which outlines any required electric system modifications and overall project capabilities, specifically:
 - 1) The amount of the generation, by unit and/or in total,
 - 2) The interconnection point voltage,
 - 3) The generator facility's intended purpose (*i.e.*, peak shaving or sale),
 - 4) Its geographic and electrical location, including feeder location where applicable.
 - 5) Electrical arrangement and protection requirements,

- 6) Electric study results of project generation impact,
 - 7) Estimated cost, funding schedule, and timeline required to implement any needed modifications to the Company's EPS to accept generation from the Generator-Owner or IC,
 - 8) Reimbursement to the Company for the operation and maintenance to be performed by the Company on the interconnection facility,
 - 9) Additional agreements deemed necessary for project acceptance,
 - 10) Contact information, name and telephone number of individual to be contacted regarding generator facility's operation, and
 - 11) Responsibility of the Generator-Owner or IC to notify the Company in writing whenever any change in the above information is contemplated, changes are subject to the approval of the Company.
3. A signed Interconnection Agreement is required between the Generator-Owner or IC and the Company before the Company will order major equipment or proceed with interconnecting the generator facility.

2.2 Cooperation

2.2.1 Overall Project

1. Any generator facility intending to operate with an interconnection to the Company's EPS shall have the approval of the Company. Generator connections for the purpose of selling to the system require approval of the appropriate Regional Independent System Operator. This approval shall be in the form of a signed Interconnection Agreement. An Interconnection Agreement will not only identify changes to the existing EPS, but will specify Generator-Owner or IC plant performance requirements that may impact the specification major electrical components within the generator facility itself.
2. If the Generator-Owner or IC enters into an agreement with a DER Aggregator, the Company will require a separate agreement with the DER Aggregator to ensure the aggregated generator facilities' operation are within the Company's requirements.
3. The Company will own, operate and maintain all electric lines and stations to the service point or POI where applicable. There will be many occasions where the close cooperation between the Company and the Generator-Owner or IC during the design, license, right-of-way acquisition, and/or construction of Company facilities will be necessary. See the Company's **ESB 751** "General Requirements Above 600-volt Service" for more information.

2.2.2 Notification and Initial Documentation

1. The Generator-Owner or IC shall contact the Company regarding their desire to operate generation in parallel with the Company EPS and negotiate necessary agreement(s). In some cases, the Company will meet with the Generator-Owner or IC to mutually establish the arrangement and location of the proposed facilities.
2. Upon notification by a Generator-Owner or IC of their intention to operate generation in parallel with the Company EPS, in writing, the Generator-Owner or IC shall define their vision of the proposed project; providing the proposed site location, overall plant capabilities, the number, and size of equipment proposed, and proposed timing of project milestones. The Generator-Owner or IC shall develop and provide a functional single-line diagram, complete with voltage and current interrupting ratings, type of equipment proposed, and all controls, complete with trip schemes, required by system protection parameters for proper protection and coordination with the EPS for Company acceptance. In addition, the specific project documentation indicated in this bulletin is also required. Three copies of each document, stamped by a State-registered professional engineer, are required unless noted otherwise.

3. Subsequent to this notification, the Company will review the project proposal and provide to the Generator-Owner or IC the estimated cost and time table for delivering the results of an electric study. The Company will respond with review comments on the concepts of the service arrangement, protective relaying, metering, and any special requirements that may be needed for an electric study (see Sections 4 and 5 herein). Data requirements for an interconnection study of generator facility projects are:

2.2.2.1 Study Phase:

Three copies of the following are necessary to begin the Company's study:

- (1) Exact physical location of the plant identified on USGS maps.

A site plan shall be submitted that is stamped and signed by a professional engineer licensed in the state where the project will be installed. The site plan shall show the location of major customer equipment, the Company equipment to be installed on site, and site details that will be helpful to define accessibility of the site. The Generator-Owner or IC shall submit a scaled site plan with location of below equipment:

- Interfacing transformer(s).
- Interrupting device(s).
- PCC.
- Mainline extension to site and from nearest PCC.
- Existing and proposed access road including, at a minimum, road material, surface loading criteria, and dimensions to confirm Company personnel and equipment access requirements are met.
- Generator location.
- Certified Scaled Site Plan and Assessor Survey Map with Wetlands.

Note that site plans shall be to scale with approximate distances indicated. In addition to site plan, the Company may ask for an assessor survey map to determine property lines, wetlands, and easements.

- (2) Overall operational output (in MW) of the generator facility.
- (3) Proposed single-line diagram of the generator facility's station showing the interconnection of major electrical components within the plant itself. This single-line diagram indicating proposed equipment ratings clearly needs to indicate:
- (i) Number, individual ratings & type of units comprising the above rating,
 - (ii) Number and size of GSU transformers, and
 - (iii) General high voltage bus configuration and relay functions.
- (4) The Company reserves the right to request additional information as needed specific to the interconnection of the generator facility's equipment including, but not limited to, three-line diagrams, control diagrams, equipment test reports and other information; see the Company's ESB 751.

Control Diagrams for < 600V Generator Facility: The Generator-Owner or IC shall submit all control diagrams (i.e., DC control schematics) of the equipment associated with the interconnection protective system. Control diagrams depict all logic used to control the interconnection protective devices. If programmable logic controllers are used for these functions, a copy of the ladder logic and reference table(s) must be included.

- (5) General operational constraints such as the ability to run various combinations of units.
- (6) The following is a list of Electrical Data Requirements:

- (i) Proposed GSU transformer MVA ratings, impedances, tap settings and winding voltage ratings.
 - (ii) Proposed machine or inverter electrical parameters noted on technical data sheets which include:
 - (iii) Machine nameplate data and reactive capability curves.
 - (iv) Impedances:
 - Direct axis and quadrature axis synchronous reactance;
 - Transient and subtransient components of positive sequence reactance data;
 - Negative sequence and zero sequence values.
 - (v) Time constants for both field open circuit and short circuit and armature short circuit quantities.
 - (vi) Turbine inertia constant.
 - (vii) Generator inertia constant: Appropriate IEEE system model including block diagram and parameter values for excitation and governor systems.
 - (viii) Inverter type and characteristics with manufacturer name and model number.
- (7) The proposed location and arrangement of Company metering equipment will be furnished by the Company and shall be included on the Generator-Owner's or IC's drawings when submitted for acceptance.

2.2.2.2 Equipment Procurement Phase:

Either before an order is placed for electrical equipment or while in equipment manufacture scheduling prior to delivery, six (6) copies of equipment specifications, Protective Relay Device List, and a Bill of Material List shall be furnished to the Company for review and acceptance. Review and acceptance by the Company shall not be construed to be an approval of the Generator-Owner's or IC's installation in regard to its overall safety or adequacy, but shall simply signify that the proposed arrangement and equipment meets the Company's interconnection requirements for connection to the Company's EPS.

2.2.2.3 Final Design Start Phase:

The documents needed to be submitted to the Company prior to beginning the final design shall include a proposed time schedule to be mutually agreed upon, a plot plan and functional single line diagram showing protection, a protective relaying scheme and revenue metering. The relay types selected to provide these functions must be acceptable to the Company. The Company will respond with the review comments on the concepts of protective relaying, metering and telemetry. This single-line diagram must be approved before final design is undertaken.

2.3 Development of an Interconnection Arrangement

2.3.1 Initial

Parallel generation will be accepted on the Company EPS at various voltage levels depending upon the generation installed and the capability of the circuit(s) to accept the electric power generated. The system will be studied in each case.

2.3.1.1 Funding:

Generator-Owners or ICs are required to establish an account with the Company. This account shall hold sufficient funds to cover the Company's estimated cost of the development of an interconnection arrangement and, upon its acceptance, scheduled payments for project installation in accordance with jurisdictional tariffs. Once sufficient funds and required data have been received, the Company will start work on the interconnection arrangement as directed by the Regional ISO.

2.3.1.2 Presentation:

A meeting will be scheduled with the Generator-Owner or IC to formally convey, explain, and answer questions regarding its content. This meeting also provides an opportunity to update information, if necessary, for the installation phase of the project.

2.3.1.3 Acceptance:

The Generator-Owner or IC shall signify acceptance of the interconnection arrangement by providing a signed Interconnection Agreement and any necessary completed generator-related Company jurisdiction-applicable tariff forms and payment of any scheduled funding. The Company will not proceed with any work until these items are received.

2.3.2 Project Scheduling

Upon acceptance of the interconnection arrangement, the Generator-Owner or IC shall submit their project schedule. This schedule and subsequent changes will be mutually agreed upon.

2.3.3 Generation Scheduling

1. Generator-Owners or ICs selling into a Regional ISO generation market will submit bids as required by that ISO. Testing and outages will also be scheduled per the Regional ISO requirements.
 - 1) In addition, for generation 10,000 kVA and larger:
 - (1) To report the expected duration of a forced outage within 48 hours.
 - (2) To report non-scheduled maintenance or forced outages upon occurrence.
 - (3) To report 3-year planned maintenance outage requirements (expected duration, desired date and time) quarterly or as changed. The Generator-Owner or IC shall agree to an overall coordinated schedule to be provided by the Company.
 - 2) The Company, at its discretion, may extend the above requirements to installations of smaller size than indicated.
2. The Generator-Owner or IC shall be required to supply reactive power support when directed by the Company's transmission system operator or Regional ISO up to the agreed specified limit.
3. All generator facilities interconnected to the distribution system and participating in the wholesale generation markets hourly or real-time dispatch, will require communication of day-ahead up to real-time dispatch signals to the Company.
4. The Company is currently providing, and will continue to provide, reactive power (*i.e.*, VAR) support to the distribution EPS. In the future, as technology and market evolution occurs, DER may also provide VAR support on a dynamic basis as requested by the Company. For advanced technologies that can provide VAR support, such as smart inverters, the Company will require manufacturer information specific to the technology to fully understand its functionality and ascertain monitoring and control requirements prior to the technology's application for VAR support.

2.4 Compliance

The Company's rights to confirm and verify the compliance of the generator installation are described in ESB 750 or 752 as applicable, ESB 751, and ESB 755. This includes energization and synchronization prerequisites, periodic checks and tests, and as-built documentation. In addition, an executed interconnection agreement shall be submitted four weeks in advance of energization.

3.0 SERVICE INSTALLATION

3.1 Service Equipment

The Generator-Owner or IC shall provide service entrance equipment as a part of their installation. The Generator-Owner's or IC's service equipment shall be rated, at a minimum, for the maximum fault current available from the Company EPS and their own contribution from the generator(s), motors, etc.

3.2 Grounding

As a minimum, the Generator-Owner's or IC's generator facility equipment shall be grounded in accordance with the latest requirements of the NEC or the NESC where the Generator-Owner or IC is under state utility regulation status. For specific installations, refer to the applicable sections of this document and the Company's ESB 750 and its applicable supplements. For neutral stabilization and ground fault requirements on distribution systems, see ESB 756 Appendices B, C, and D.

3.3 Metering

The Company reserves the right to determine that all metering schemes allow for the proper administration of all contracts and rates (whether retail or wholesale). Additional Company metering requirements are specified in the appropriate sections of this ESB 756 Appendix A and the Company's various jurisdiction-applicable electricity tariffs, as filed and Regional ISO requirements, as applicable within the process.

3.3.1 Metering Requirements in MA, NH, RI, and VT Jurisdictions

1. For Distribution Metering requirements under the Company's jurisdiction-applicable retail electricity tariffs in MA and RI, refer to the Company's ESB 750 and ESB 756 Appendices C and D at <http://www.nationalgridus.com/electricalspecifications>.
2. For Transmission Interconnectors' metering and communication requirements in MA, NH, RI, and VT, refer to ISO-NE OP-18 and all appendices at https://www.iso-ne.com/static-assets/documents/rules_proceeds/operating/isone/op18/op18_rto_final.pdf.

3.3.2 Metering Requirements in Upstate NY Jurisdiction

1. For Distribution Metering requirements under the Company's jurisdiction-applicable retail electricity tariff in NY, refer to the Company's ESB 750 and ESB 756 Appendix B at <http://www.nationalgridus.com/electricalspecifications>.
2. For Transmission Interconnectors' metering and communication requirements in NY, refer to NYISO "Revenue Metering Requirements Manual", No. 25 at http://www.nyiso.com/public/webdocs/markets_operations/documents/Manuals_and_Guides/Manuals/Administrative/rev_mtr_req_mnl.pdf.

3.3.3 General Parallel Generation Requirements for Company Metering

1. Details of the installation requirements are covered in ESB 750 and its appropriate Supplement. For generator facilities connected to distribution systems, see also ESB 756 Appendices B, C, and D.
2. Where energy will be sold to the Company, a directional revenue metering system will be installed.
3. Normally, for installations with directional revenue metering the connection of the Company's metering instrument transformers must have a potential transformer (PT) connected on the generator side of the current transformer (CT). The instantaneous relative polarity of metering instrument transformers is critical to proper operation. CTs must be positioned such that the polarity dot or marking is on the Company side.

4. Revenue meters will either be equipped with detent functionality, or will be capable of bi-directional measurement. "Detented metering" measures and registers power flow in a single direction by either mechanical or electronic means.
5. A directional revenue metering system will be installed to capture bi-directional kilowatt-hours (kWH). Depending on magnitude of load/generation, kilowatt demand (kW) and kilovar-hour (kVARH) quantities will also be captured. For those installations having a "Buy All-Sell All" purchase agreement contract, an additional interval based kWH meter will also be installed on the output of the generator(s).
6. Where NEM does not apply or for peak shaving generator applications excluded from BTM or excess sales arrangements, there is no obligation for the Company to accept surplus power and in those cases, the Company's revenue metering will be detented.
7. In NY at the Generator-Owner's or IC's request and cost, the Company will furnish equipment for energy pulse signals. These signals will be at the point of the metering and will represent the kWH energy for operation of their equipment. These signals are for information only and the Company shall not be liable for distorted or missing pulses.
8. Where applicable under the Company's jurisdiction-applicable tariff, Non-Residential Customers with OSG are subject to billing adjustments, for example primary served/secondary metered customers. Additional metering will be installed at the Generator-Owner's or IC's expense in order to measure the appropriate adjustment.
9. The Company will make the final determination of telecommunications service requirements for Company-owned revenue metering.
10. The Generator-Owner or IC is responsible for arranging for installation and payment of all costs associated with the telecommunication service to each Company-owned revenue meter board; see Section 4.2. They are also responsible for all maintenance costs and recurring telecommunication charges.

4.0 PLANT REQUIREMENTS

4.1 Telemetry

4.1.1 Telemetry Criteria

1. The Company reserves the right to determine all telemetry and supervisory control data acquisition (SCADA) schemes to allow reliable operation of the electric system and for the proper administration of all contracts.
2. For all installations 1,000 kW or larger, telemetry of data, control and/or status of devices as specified by the Company is required (see ESB 756 Appendices B-D for distribution parallel connected DER, ESS, and generators). The Company also reserves the right to extend the need for telemetry to less than 1,000 kW generators or where Merchant Plants desire this equipment for their Regional ISO requirements. This information is for the Company's Energy or Distribution Management Systems (EMS or DMS) and will require the installation of Remote Terminal Unit (RTU) equipment in the Generator-Owner's or IC's facilities. *Exception: Where the Company supplies a PCC recloser, SCADA provisions may be sufficient for the EMS reporting requirements and a generator facility EMS-RTU is not required for status and control (see ESB Appendices B-D for more information).*
3. Subject to the jurisdictional applicable tariff, the Company or the Generator-Owner or IC will furnish the telemetry RTU for the installation. The Company will specify the communication protocol, polling frequency, transducers, sensors or other components that the Generator-Owner or IC will purchase and acquire. Where equipment is furnished by the Company under the Company's jurisdiction-applicable tariff, it will remain Company property and will be maintained by the Company.
4. All dispatch signals whether from the Regional ISO or DER aggregator will be transmitted to the Company utilizing Company-specified communication system protocols.

4.1.2 Telemetry Specifications for Company-provided RTU

1. The RTU cabinet is typically 42" H x 30" W x 26" D shall be wall-mounted with the bottom edge 36" above the floor. A 5-foot clear working space shall be maintained in front of the mounting panel.
2. A dedicated 20A, 120VAC, single phase 60 hertz power circuit is required for the RTU cabinet. All conduit and wiring (minimum of No. 10 AWG copper) to the telemetry cabinet for this circuit shall enter the cabinet from the bottom. A three (3) foot length of all conductors shall be provided for final Company connection.
3. A dedicated 10A, 48VDC or 125VDC input is required to the RTU directly from the station battery.
4. The Generator-Owner or IC will be responsible for mounting this equipment in their installation, subject to Company approval. The Generator-Owner or IC will provide space, power and all input connections for this package, in the same area with the metering equipment (see ESB No. 752).
5. The following guidelines shall be adhered to:
 - 1) The RTU shall be located indoors within 15 feet of the billing meters to facilitate testing and calibration.
 - 2) The RTU shall be remote from heavy traffic areas, work areas and loading areas.
 - 3) The RTU shall be remote from heat producing or high electrostatic or electromagnetic field producing equipment.
 - 4) The RTU shall be remote from station batteries.
 - 5) The analog inputs to the RTU shall be provided by DNP3 protocol communication. Where DNP3 communication is unavailable, the analog inputs shall be +1.0mA DC at rated input, +2ma DC maximum. The analog metered inputs required as metered at delivery point are as follows:
 - Net kW (+) - To the Company EPS
 - Net kW (-) - From the Company EPS
 - Net kVAR (+) - To the Company EPS
 - Net kVAR (-) - From the Company EPS
6. Where the Generator-Owner's or IC's system includes generation and plant load, the metered values shall be the net sum of power from the Company's EPS, and the generation minus any internal plant load, which may be connected to the generator output circuits.
7. The Accumulator inputs to the RTU shall be:
 - Net kWh (+) - To the Company EPS
 - Net kWh (-) - From the Company EPS
8. The bi-directional metering equipment for telemetry shall be capable of providing instantaneous power and a pulse output that is proportional to integrated energy.
9. Additional inputs that normally will be required are:
 - Phase Voltage (kV) and Current (Amps) - measured at the interconnection bus (service voltage)
 - Circuit breaker(s) control and/or status
 - Motor operated disconnect(s) status
 - Instantaneous value of frequency (Hz) - if so specified
 - Ring bus station voltage, current, active and reactive power at several locations.

Note: The Company will provide an EMS-RTU point list for inputs required at the Generator-Owner's or IC's facility.

4.1.3 Telephone Installation Specifications for Company-provided RTU

1. A plywood panel 3/4" x 48" x 48" is required for the telephone equipment. A four (4) foot clear working space shall be maintained in front of this panel. The Generator-Owner or IC will install terminal blocks directly adjacent to the telephone equipment for interconnection of the Company's EMS-RTU.
2. A dedicated 20A, 120VAC, 60 hertz power circuit is required for the telephone equipment. The Generator-Owner or IC shall provide all conduit and wiring for the circuit and install one 20A, 120VAC, single phase convenience receptacle at the telephone equipment location.
3. Refer to Section 4.2 herein for telecommunication provider steps and requirements.

4.2 Telecommunications Steps and Requirements

1. The local serving telephone company's facilities demarcation and equipment shall be located as close to the RTU cabinet and protection relays, as feasible, relative to the Generator-Owner's or IC's mutually agreed upon location.
2. The Generator-Owner or IC is responsible for arranging the installation and paying all costs associated with required telecommunication line(s) for all RTU and tele-protection circuits (e.g., DTT) including maintenance and recurring telephone company charges as documented in the interconnection study or interconnection agreement.
3. The Generator-Owner or IC shall be responsible for all telephone company coordination, installation, final connections, and commissioning of all required telecommunication circuits.
4. The Generator-Owner or IC is responsible to complete their telephone company's high voltage protection (HVP) form when arranging for the telecommunication service. The technical information normally provided includes, but not limited to: total square footage area of Ground Grid/Mat, Grid Impedance (in Ohms) to Remote Earth, total expected Fault Current (line-to-ground) in Amps RMS (or Amps Peak), Earth Return Current (as % of Total Fault Current), X/R Ratio, and Soil Resistivity (layer depth information in feet).
5. The Generator-Owner or IC is responsible to comply and coordinate with their telephone company's commissioning process of telecommunications circuits required with the Company.

4.3 Power Quality

Utility lines are subject to many natural and man-made hazards. The Company does not assume any responsibility for protection of generation or other electrical equipment. The Generator-Owner or IC is fully responsible for protecting all of their equipment from damage due to faults and other disturbances, irrespective of the condition of the Company's EPS. The Generator-Owner or IC shall not impact the Company's EPS power quality characteristics.

4.4 Performance/Design

4.4.1 Generator Criteria

1. The Generator-Owner or IC shall provide generator controls to maintain proper voltage, frequency, and line current balance and permit synchronizing with the Company EPS. The generator facility's electrical output shall meet the performance requirements of the latest IEEE Standard 519 and ANSI C84.1 at the time it goes into service.
2. All generation projects operating in parallel with the Company's EPS shall not adversely impact the existing system operation. Transmission lines shall remain within thermal ratings for normal and contingency conditions and the proposed project shall be capable of operation at full output over the range of system operating voltages. This range includes the normal nominal voltage range of 1.05p.u. to 0.95p.u. and the emergency range, which can extend to 0.90p.u. for short periods of time.
3. Projects utilizing synchronous and doubly-fed asynchronous machines are required to have excitation systems capable of automatic terminal voltage control. In general, long term

operation with constant excitation (manual mode) is not acceptable. If power factor control is available it must be automatically disabled following a system disturbance to ensure sustained reactive support after an event. Power factor control and automatic voltage control schemes shall be mutually agreed between the Generator-Owner or IC and the Company. These requirements may typically lead to operational power factors at the Wholesale Delivery Point ranging between 0.9 lagging (VARs to the power system) and 0.95 leading (VARs from the power system). (Retail electric load customers with on-site generation shall provide reactive power support such that the retail load power factor is not degraded at the Retail Delivery Point.)

4. Projects utilizing induction machines will be required to utilize switched shunt compensation within their facility to minimize system voltage impacts over a wide range of the entire power output. Local power system requirements may lead to operational power factors at the Wholesale Delivery Point or Retail Delivery Point ranging between 0.9 lagging (VARs to the power system) and unity. These facilities will also be required to meet the latest Regional ISO, NPCC, or local regional planning criteria. The overall project power factor requirements shall be mutually agreed between the Generator-Owner or IC and the Company.

5. Voltage and Frequency Control:

Plant equipment is required to remain on line and fully operational throughout this recovery period. Voltage and frequency ride through and trip points for generation connected to the Company's EPS shall meet two standards, IEEE 1547 and/or NERC PRC-024-2¹⁰ depending on the size and type of the generator facility and where Regional ISO voltage and frequency requirements apply. Where a wholesale generator is proposed for a distribution system and the Regional ISO voltage and frequency requirements do not apply, the IC shall refer to the Company's ESB 756 jurisdiction applicable Appendices B, C, or D and IEEE 1547.

- 1) Inverter-based generators connected to distribution systems shall be in compliance with the latest version of IEEE 1547 and shall refer to ESB 756 Appendices B, C, and D.
- 2) Generator plants including small distributed generators shall conform to the latest version of IEEE 1547 for their voltage and frequency settings where connected to distribution systems.
 - No distributed generators shall have an under-frequency trip setting higher than 58.9 Hz, as to not conflict with the under-frequency load shedding schemes in the Company's EPS.
 - The "adjustable" under frequency setting shall not fall within the prohibited region of NERC PRC-024-2.
- 3) Generator facilities that have aggregate generation greater than 20MVA and connected through a GSU transformer to a transmission line that is greater or equal to 100kV shall conform to the current NERC PRC standards including NERC PRC-024-2. These generators are considered part of the "Bulk Electric System" ("BES").
 - Power plant auxiliary equipment shall not trip or stall for momentary under voltage or over voltage excursions anticipated by planning criteria.

Note that consistent with IEEE 1547, the pickups are exact set points and the time delays are maximum total clearing times (including relay and device interruption time). In PRC-024-2, the pickups and time delays are the algorithm for a "prohibited region." The Generator-Owner's or IC's settings do not need to be exactly on the lines for this prohibited region, they just cannot be within the region that the lines envelop. IEEE 1547 focuses toward

¹⁰ See <https://www.nerc.com/pa/Stand/Pages/ReliabilityStandards.aspx> and <https://www.nerc.com/pa/stand/Pages/ReliabilityStandardsUnitedStates.aspx?jurisdiction=United%20States>.

maintaining power quality and safety, since a majority of the systems it applies to are on the distribution EPS, close to customer loads and more susceptible to faults. The PRC rules focuses on maintaining the reliability of the BES, and preventing system collapses. For more information, see:

- Institute of Electrical and Electronics Engineers (IEEE) Std. 1547 “Standard for Interconnection and Interoperability of Distributed Energy Resources with Associated Electric Power Systems Interfaces”
- NPCC reliability criteria: <https://www.npcc.org/Standards/Directories/Forms/Public%20List.aspx>
- NPCC Directory 12 Curve, Figure 1 for the adjustable underfrequency set point (Eastern interconnection):
<https://www.npcc.org/Standards/Directories/Directory12%20Full%20Member%20clean%2020150330%20GJD.pdf>
- PRC-024-2 (Eastern interconnection):
http://www.nerc.com/_layouts/PrintStandard.aspx?standardnumber=PRC-024-2&title=Generator%20Frequency%20and%20Voltage%20Protective%20Relay%20Settings&jurisdiction=United%20States

4.4.2 Step-up Transformer Specification

1. GSU transformer connections and winding configurations shall be reviewed and approved by the Company before procurement by the Generator-Owner or IC. Acceptable equipment parameters are often determined by the location on the electrical system. The winding arrangement shall be such that the Company’s EPS remains effectively grounded. For generator facilities connected to distribution systems, see ESB 756 Appendices B, C, and D.
2. GSU transformer and auxiliary transformers shall have no-load tap settings and impedances coordinated with power system voltage control requirements and unit capabilities.

4.5 Plant Protection

4.5.1 Plant Protection Criteria

1. Excitation equipment shall have an over excitation limiter coordinated with the thermal capability of the generator field winding. Longer over excitation time shall allow less overcurrent. The over excitation limiter shall also be coordinated with over excitation protection so that over excitation protection only operates for failure of the voltage regulator/limiter. Return to automatic voltage control after an over excitation event shall be automatic.
2. Under excitation limiters shall coordinate with generator capability (stator end-region heating) and power system stability limits. These settings shall also coordinate with loss of excitation protection.
3. Volts/hertz limiter equipment shall coordinate with volts/hertz protection.
4. Prime mover control (governors) shall operate freely to regulate frequency. Droop setting shall be in accordance with Regional ISO/NPCC/NERC standards. Prime movers operated with main valves or gates wide open shall control for over speed/over frequency. Boiler or nuclear reactor control and protection shall coordinate to meet the economic and safety requirements of the plant while maintaining the capability of the generator to aid in the control of system frequency during a power system disturbance.
5. Prime mover over speed controls shall be designed and adjusted to prevent boiler upsets and trips during partial load rejection characterized by abnormally high system frequency.
6. Recording of performance during disturbances shall include generator terminal voltage and real and reactive power. Monitoring of other quantities such as field voltage and current, power system stability (PSS) output frequency or speed is best practice. These event recorders shall have adequate resolution and bandwidth to fully capture dynamic response of the generator.

7. Protection shall allow temporary excursions in speed and system frequency anticipated by planning models without tripping. Such protection shall include over/under frequency relays as well as boiler safeguards. Under frequency protection shall be coordinated with the Regional ISO/NPCC/NERC under frequency load shedding program.
8. Generator protection shall allow temporary voltage excursions anticipated by planning models without tripping. This protection shall include volts per hertz relays, generator auxiliary equipment under voltage relays, loss of excitation relays, backup distance relays, generator and transformer overcurrent relays, and out-of-step relays. These protection characteristics and settings shall be available to the Company upon request.
9. For parallel generation interconnected greater than 15kV, frequency protection employed on all rotating apparatus shall allow the system time to recover by keeping units on-line during short term frequency excursions. With reference to NERC PRC-024-2 above, a region is indicated during which the system frequency is recovering. Generation shall remain on line during this period. The lower bound is established by Regional ISO/NPCC/NERC criteria. The upper bound is for uniformity among projects taking into consideration equipment capabilities and the characteristics of the system response. All generation shall be capable of operating within this region.

4.5.2 Automatic Switching and Protective Devices

1. The generator facility shall employ the use of a properly applied interrupting device capable of automatic operation to interrupt the generation facility from the Company's EPS. The device to be used shall be reviewed and approved by the Company before procurement by the Generator-Owner or IC. The Generator-Owner or IC shall provide protection as determined by the Company on a site-specific basis.
2. The Company shall review and approve the protective relay devices provided by the Generator-Owner or IC for protection schemes required by the Company to protect its system. The use of utility grade relays and relay redundancy is a normal Company requirement. See Exhibit 1 for a reference list of most device nomenclature.
3. For interconnections on the Company's transmission system, frequency relays, where used, shall have ranges to meet the requirements of the Plant Abnormal Frequency Requirements Curve, see NERC PRC-024-2 referenced above. Voltage relays, where used, shall have ranges to meet the Company's transmission planning criteria of $\pm 5\%$ from nominal voltage and -10% for emergencies and those in NERC PRC-024-2.
4. Protective relay devices provided by the Generator-Owner or IC for Company-required protection schemes shall meet Company test device requirements.
5. Exclusion of Current Transformer Selector Switches: Meter selector switches shall not be connected into the secondary circuits of current transformers used with protective relays specified by the Company. Metering shall not be connected in protective relay circuits.
6. It is Company practice to automatically reclose line circuit breakers, without employing synchronism check protection, within a few seconds after they have automatically been opened. For specific distribution EPS reclosing, see ESB 756 Appendices B, C, and D.
7. Anti-islanding: Following a DER generator disconnection as a result of Company distribution source loss, the generation shall remain disconnected until such time as the Company source has recovered to Company acceptable voltage and frequency limits for a minimum of five (5) minutes. For merchant power plants, reconnection to the Company's transmission source shall be made through mutually agreed operating procedures and switching protocol with the Company's Transmission Control Center. There are severe safety and potential equipment damage issues associated with feeding power into a de-energized EPS. Any Generator-Owner's or IC's installation's protection system shall be designed with interlocks and proper protective functions to ensure that there is proper voltage, frequency and phase angle conditions between the Company's EPS before the generator facility is permitted to parallel. Therefore, anti-islanding protection control is

required for parallel generation on the Company's EPS. If the Company determines that an active anti-islanding protection scheme is required to mitigate the risk of a formation of an island in addition to the generator facility's own anti-islanding control scheme then the Generator-Owner or IC may propose alternative methods of anti-islanding protection of their own generation facility that can see and trip for faults on the utility EPS and any upstream device opening. It is the Generator-Owner's or IC's responsibility to demonstrate comprehensively the validity of such methods and the Company reserves the right to make the final determination as to which anti-islanding protection method is suitable to meet the EPS safety and reliability requirements. The use of direct transfer trip (DTT) is a definitive protection means for anti-islanding protection under good utility practice. DTT typically requires utility substation modifications to send a signal to trip the Generator-Owner's or IC's facility offline when the substation breaker opens. This also typically requires the Generator-Owner or IC to lease a communication medium between the substation and the production facility, as well as install a receiver and tripping device in their equipment. DTT has inherent high costs and physical limitations associated with equipment installation due to the typical leased telecommunication line requirement at the EPS source and at the generator(s), as well as required utility substation modifications. The initial and recurring costs for DTT are at the expense of the interconnecting customer.

Note: A Customer wishing to use a generation system as a stand-by or emergency generator shall submit details regarding an interlocking scheme or transfer switch to prevent the energization of a de-energized Company circuit that complies with National Grid ESB 750, Section 11.

8. **Transmission Ground Fault Detection:** The addition of generation sources to distribution feeders can result in the backfeeding of the substation transformers, effectively turning a station designed for load into a generation step-up transformer. The Company's most common distribution substation transformer has a delta connection on the transmission side and a wye-grounded connection on the distribution side. Due to the transformer's configuration,¹¹ it cannot contribute zero sequence ground fault current to single line to ground faults on a transmission line, and the voltage on the unfaulted phases rises significantly and rapidly. These overvoltages have the potential to exceed insulation levels of the station and transmission line equipment, and maximum continuous operating voltage of surge arresters. This situation can also leave transmission ground faults energized by the distribution-connected production facilities (e.g., DER and DG). Zero sequence voltage protection (commonly referred to as "3V₀") on the primary side of the transformer is required in order to detect these overvoltage conditions. This 3V₀ protection will disconnect the generation from the substation transformer, and stop the generation and transformer from contributing to the transmission-side overvoltage condition.

If the Company determines there is a likelihood of a zero sequence overvoltage event, transmission ground fault detection equipment and substation modifications may be required. Three voltage sensors (typically coupling capacitor voltage transformers (CCVT), are connected to the transmission side of the utility substation transformer. These voltage sensors are wired to a 59N relay (3V₀ function), which trips the Generator-Owner's or IC's facility offline via utility breakers in the substation. This helps de-energize the ground fault from all sources. Some substations may require protection for detecting transmission ground faults other than 3V₀. Customers should be aware that these modifications to the Company's substations require significant cost and time to install. The cost and time requirements are provided in the interconnection studies according to the applicable jurisdictional state or Regional ISO tariffs when performed for the Generator-Owner or IC.

¹¹ There may be other transformer configurations for which zero sequence continuity is broken and/or the production facility is unable to reliably detect and trip offline for transmission ground faults. The Company determines when and which type of transmission ground fault detection is required based on the substation configuration on a case-by-case basis.

9. For specific technical requirements of parallel generation to the **Company** distribution **EPS**, see ESB 756 Appendices B, C, and D.

EXHIBIT 1: REFERENCE LIST OF STANDARD DEVICE NUMBERS

(See latest edition of ANSI C 37.2)

<u>Device Number</u>	<u>Function</u>
25	Synchronizing Device
27	Undervoltage Relay
32	Directional Power Relay
46	Negative Sequence Voltage
50	Instantaneous Overcurrent Relay
51	Phase Overcurrent Relay
51C	Voltage Controlled Overcurrent Relay
51N	Neutral Overcurrent Relay
51V	Overcurrent Relay, voltage restraint
52	Breaker
52R	Recloser
59	Overvoltage Relay
59G	Neutral Voltage Relay
59N	Zero Sequence Voltage Relay
62	Time-delay Stopping or Opening Relay
64	Ground Protective Relay
81	Over and Under Frequency Relay
86	Locking - Out Relay
87	Differential Relay

(Refer to latest editions of NFPA 70B or IEEE Standard 141 for typical electrical single-line diagram development.)

4.5.3 Relay Settings and Testing

1. Protection shall be provided by the Generator-Owner or IC such that abnormal conditions on the Company's EPS will not cause damage to generator facility equipment. Protection also shall be provided by the Generator-Owner or IC such that abnormal conditions in the generator facility equipment will not cause equipment damage or abnormal conditions on the Company's system.
2. Company-designated Relays and Generator-Owner or IC Settings: The Company will review for acceptance the Generator-Owner's or IC's settings and the calibration and test results of those relays that the Company's Protection Engineering Department designates as being required to satisfy the Company's protection practices. In addition, the Company may require the relaying summary and logic diagrams depending on the complexity of the installation. Any relay setting issued by the Company shall not be changed or modified at any time without the prior written consent of the Company.
3. Company Verification of Relay Testing: Upon initial installation or modification, the Company requires a letter from the Generator-Owner or IC stipulating that all Company-designated protective devices shall have:
 - control wiring verified against the accepted design drawings, and
 - the calibration test performed satisfactorily according to the relay setting document of the accepted design.

The Company reserves the right to witness the Generator-Owner's or IC's functional test of the required devices, *i.e.*, trip tests. This activity will normally be performed on a mutually accepted schedule. At the Company's sole discretion, the calibration and test by a third party with Company approval of results may be an option. Refer to ESB 755 for additional details on the Company's policy regarding maintenance.

4. **Generator-Owner or IC Supplied Relay Settings and Testing:** The Generator-Owner or IC shall be responsible to specify the settings, calibrate, test, and maintain the balance of their equipment.
5. The NPCC has established criteria for periodically testing under frequency relays and reporting their performance used for load shedding critical to system security. Details of schedules, testing and reporting methods will be made available prior to synchronization.

5.0 OPERATING

5.1 Manual Disconnect Switch

The Generator-Owner or IC shall furnish and install an electrical load break disconnect switch accessible at all times to the Company. For disconnect switch requirements of generator facilities connected to distribution systems, see ESB 756 Appendices B, C, and D. This disconnect shall be connected between the Generator-Owner's or IC's facility and the connection point to the Company EPS. The visible disconnecting means may consist of a group-operated load air break switch and fuse, or group operated air break switch and circuit breaker. It shall be capable of being locked in the open position and have provisions for both Company and Generator-Owner or IC padlocks. This disconnect device shall be identified by a permanent sign as designated by the Company. Operation of this switch for any change in its status shall be immediately reported to the Company.

5.2 Disconnection by the Company (Isolation)

- 5.2.1 The Company reserves the right to open or order open the connection to the Generator-Owner or IC via circuit breaker, switches, etc., to isolate the Generator-Owner's or IC's equipment without prior notice for the following reasons:
 - 5.2.1.1 Emergency conditions on the transmission system that need to be relieved immediately requiring such action. Emergencies include but are not limited to:
 - Voltage excursions in excess of $\pm 5\%$ of nominal.
 - Transmission system elements subjected to loading (pre- or post-contingency) in excess of thermal ratings where disconnection alleviates the problem.
 - Situations involving restoration of service.
 - Excess generation on the Company's EPS.

Note: When reduced generation output alleviates the problem, it may be ordered by the Company.
 - 5.2.1.2 When the Company's periodic check of Generator-Owner's or IC's equipment reveals a hazardous condition, a lack of necessary maintenance, or a lack of maintenance records for equipment necessary to protect the Company's EPS.
 - 5.2.1.3 When generating equipment interferes with other generator facilities, other customers, or with the operation of the Company's equipment. See Section 4.4.1 herein for Generation Criteria.
 - 5.2.1.4 When required protective relaying and/or tele-protection is altered, inoperable, or missing.
 - 5.2.1.5 When required special equipment necessary for operating control (e.g., telemetering/SCADA) on the Company's EPS is inoperable or missing.
- 5.2.2 Only the Company may permit the Generator-Owner or IC to energize a de-energized Company circuit for system restoration.

5.3 Other

1. In some instances, it may be required for Company operation of circuit protective devices and switches integral to the Company EPS within the Generator-Owner's or IC's facility.

2. Sequence of events recorders shall be installed to log events such as limiter operation and protective trips (target logs) and generator performance during severe disturbances.
3. The Company or Regional ISO may, during emergency situations, implement voltage reduction as a load relief measure. The Generator-Owner or IC is responsible for any additional equipment necessary to remain on-line during such voltage reductions, refer to Section 4.0 herein.
4. Should the Generator-Owner's or IC's generator facility experience unexpected tripping of their interrupting device, the Generator-Owner or IC shall first perform their own extensive analysis of all possible causes for trips of their own system before attempting to resolve those issues through the Company.
5. Refer to Section 2.1.1 herein and ESB 755 for other Generator-Owner or IC operating responsibilities.

6.0 REVISION HISTORY

Version	Date	Description of Revision
1.0	06/01/07	Initial version of new document superseding all previous revisions of ESB 756.
1.1	09/06/11	Permit study of DG on area networks in Section 1.1, no other technical changes, only formatting and general editing based on September 2010 ESB 750 Series Errata changes.
1.2	09/22/14	Added reference in Section 2.2.1.2 to ESB 751 released in June 2014. Editorial correction to Table header in Section 4.5.2.8.5.
2.0	08/03/17	June 2017 major revision incorporating NY, MA, RI, NH, and VT jurisdictions and good utility practice changes.
2.1	12/15/17	October-December 2017 interim amendments to Sections 4.1.1.2 and 4.4.1.5.
3.0	06/29/18	June 2018 revised for IEEE 1547-2018 and updated National Grid practices.
4.0	12/04/19	December 2019 revised for updated National Grid practices.

Electric System Bulletin No. 756 Appendix B:

Distributed Generation Connected To National Grid Distribution Facilities Per The New York State Standardized Interconnection Requirements

Version 6.0 12/04/2019

ESB 756 Appendix B is part of the ESB 750 series

TABLE of CONTENTS

SECTION	PAGE
TABLE of CONTENTS.....	2
1.0 Purpose	4
2.0 Scope.....	4
3.0 Applicable Codes, Standards, and Guidelines.....	5
4.0 Definitions	6
5.0 Interconnection Customer Interface Procedures.....	7
5.1 APPLICATION PROCESS OVERVIEW	7
5.1.1 Interconnection Customer Technical Data Submission	8
5.1.1.1 Control Diagrams	8
5.1.1.2 Interconnection Facility Equipment Data Sheets	8
5.1.1.3 Site Plan	8
5.1.1.4 Data Required for Energy Storage System Applications	8
5.1.1.5 Data Required for Facility or Campus-style Microgrid Applications.....	9
5.2 INTERCONNECTION PROCESS – NON EXPEDITED	9
5.3 OBJECTIVES IN THE APPLICATION PROCESS	9
5.4 SPECIAL SYSTEM CONSIDERATIONS	11
5.4.1 Secondary Grid and Spot Network Areas.....	11
5.5 INTERCONNECTION CHARGES.....	12
Table 5.5-1: DER Projects Not Eligible for the Expedited Process where no EPS upgrades are expected.....	13
Table 5.5-2: DER Projects Not Eligible for the Expedited Process (Complex)	13
6.0 Potential Issues Related to Interconnection.....	13
6.1 GENERAL CONSIDERATIONS.....	13
Illustration 6.1.5-1: Typical DG Installation Areas on Radial Distribution Feeders.....	14
6.2 SIGNIFICANT EPS CONSIDERATIONS	15
6.2.1 Direct Transfer Trip	15
6.2.2 Transmission Ground Fault Detection	16
Illustration 6.2.2-1: Simple One Line for Transmission Ground Faults for Typical Substation Transformer Configuration.....	16
7.0 General Design and Operating Requirements	17
7.1 GENERAL CRITERIA	18
7.1.1 Delivery Voltage.....	18
7.1.2 Single Phase.....	18
7.1.3 Three Phase	18
7.1.4 Phase Balance and Voltage Tolerance	18
7.1.5 Neutral Stabilization, Ground Fault, and Grounding	18
7.2 SERVICE EQUIPMENT AND REVENUE METERING	19
7.2.1 Service Equipment Requirements.....	19
7.2.2 Company Revenue Metering Requirements.....	20
7.2.2.1 ESS paired with DG	21
7.2.3 Company Revenue Metering Requirements for VDER of Paired ESS plus Renewable DG.....	21
7.3 TRANSFORMER.....	21
7.3.1 Secondary Served Customers.....	21
7.3.2 Primary and Higher Voltage Served Customers	21
7.3.2.1 Effectively Grounded, Four-wire Multi-grounded 3-phase Wye EPS:.....	21
7.3.2.2 Not Effectively Grounded, Three-wire 3-phase EPS:.....	22
7.4 MANUAL GENERATOR DISCONNECTING MEANS.....	22
7.5 GENERATOR INTERRUPTING DEVICE REQUIREMENTS.....	24
7.5.1 General.....	24
7.5.2 Local Power Supply Requirements	24
7.6 PROTECTION AND PROTECTIVE EQUIPMENT REQUIREMENTS.....	25

TABLE of CONTENTS

<u>SECTION</u>	<u>PAGE</u>
7.6.1 Type Tested (Certified) Equipment.....	26
7.6.2 Non-Type Tested Equipment	26
7.6.3 Number of Relays Required	26
7.6.3.1 Certified Inverter-based Energy Resource Protection Requirements.....	26
7.6.3.2 Non-Certified Energy Resource Protection Requirements.....	27
7.6.4 Instrument Transformers for Protective Device Relays.....	27
7.6.4.1 Current Transformers (CT).....	27
7.6.4.2 Voltage Transformers (VT) and Connections	27
7.6.5 Protective Relay and Trip Circuit Hard-Wire Requirements	27
7.6.6 Protective Relay Test Switch Requirements.....	27
7.6.7 Voltage Relay Devices	28
7.6.8 Frequency Relay Devices	28
7.6.9 Synchronizing Devices.....	28
7.6.10 Overcurrent Relay Devices	28
7.6.11 Utility Grade Relay and Protective Device Settings and Verification.....	28
7.6.11.1 Default Voltage and Frequency Set points for all types of Energy Resources	28
Table 7.6.11.1-1 Utility Grade Relay and Parallel Generation Default Voltage & Frequency Set points	29
7.6.11.2 Synchronism Check Setting Requirements for all types of Generation.....	29
Table 7.6.11.2-1 Relay Settings to Parallel with the Company EPS	29
7.6.11.3 Company-designated Relays and Interconnection Customer Settings	29
7.6.11.4 Company Verification of Relay Testing.....	29
7.6.12 Unintentional Islanding Protection for DER.....	30
7.6.12.1 General.....	30
7.6.12.2 Islanding risk mitigation methods required	31
7.6.12.3 Certified DER	31
7.6.12.4 Non-certified & voltage or frequency regulating inverters, induction & synchronous machines	32
7.7 MONITORING AND CONTROL (M&C) AT DER FACILITY	32
Table 7.7-1 Monitoring and Control Requirements by Size for DER (1).....	32
7.8 VOLTAGE AND FREQUENCY RIDE THROUGH AND CONTROL REQUIREMENTS.....	35
7.8.1 Voltage and Frequency Ride Through.....	35
7.8.2 Voltage and Frequency Control.....	35
Table 7.8.2.2-1: Default Mode Settings for Inverter-based Utility Interactive DER	35
7.8.3 Return to Service	35
Table 7.8.3-1: Return to Service Parameters for DER.....	35
8.0 Testing and Commissioning.....	36
9.0 Operating.....	36
10.0 Power Quality Monitoring	37
10.1 POWER QUALITY COMPLIANCE VERIFICATION	37
10.2 POWER QUALITY DISTURBANCE AND MITIGATION.....	37
10.3 TRANSIENT OVERVOLTAGE/LOAD REJECTION OVERVOLTAGE (LROV).....	37
11.0 Facility Audit	37
12.0 Disconnection by the Company (Isolation)	37
13.0 REVISION HISTORY	38
EXHIBITS ATTACHED.....	38
EXHIBIT 1: COMPANY REQUIREMENTS FOR DER SYSTEMS NOT ELIGIBLE FOR THE EXPEDITED PROCESS.....	39
EXHIBIT 2: REFERENCE MAPS OF NATIONAL GRID UPSTATE NY SECONDARY NETWORK EPS AREAS.....	40
EXHIBIT 3: DISTRIBUTION SECONDARY GRID AND SPOT NETWORK DESCRIPTION	41

TABLE of CONTENTS

<u>SECTION</u>	<u>PAGE</u>
EXHIBIT 4: RECOMMENDED GUIDELINES FOR RESIDENTIAL AND COMMERCIAL SINGLE-LINE DIAGRAM SUBMITTALS	42
FIGURE 1: SAMPLE DISTRIBUTED GENERATOR ONE-LINE DIAGRAM	43
FIGURE 2: TYPICAL SYMBOLOGY FOR ELECTRICAL DRAWINGS	44
EXHIBIT 5: RECOMMENDED GUIDELINES FOR FUNCTIONAL SINGLE-LINE DIAGRAM SUBMITTALS	45
FIGURE 3: SAMPLE FUNCTIONAL SINGLE-LINE DIAGRAM	46
FIGURE 4: TYPICAL 3V ₀ REQUIREMENTS FOR LOCAL EPS GROUND FAULT DETECTION	47
FIGURE 5: TYPICAL OVERHEAD SINGLE PRIMARY SERVICE CONFIGURATION IN NY FOR LARGE DER INSTALLATIONS	48
EXHIBIT 6: NET METERING COMPLIANCE VERIFICATION CHECKLIST	49

1.0 Purpose

1. Electric System Bulletin (ESB) 756 Appendix B covers requirements for interconnecting customers proposing to install a distributed energy resource (DER) system (“Interconnection Customer” or “Customer”) to National Grid’s (the “Company”) upstate NY electric power system (EPS) for State jurisdictional projects.
2. ESB 756 Appendix B does not cover the technical state and federal transmission operator jurisdictional requirements (New York Independent System Operator (NY ISO) and Federal Energy Regulatory Commission (FERC)) for connection to the Company’s transmission EPS, community microgrids, and parallel operated DER systems and on-site generators (OSG) larger than 5 MW that are covered by the Company’s ESB 756 Appendix A.¹
3. This ESB supplements **ESB 750** and the New York State Standardized Interconnection Requirements and Application Process For New Distributed Generators 5 MW or Less Connected in Parallel with Utility Distribution Systems (**NY SIR**) covered in Rule 53 of the Company’s P.S.C.² No. 220 Electricity Tariff and provides general technical requirements, recommendations, and assistance to customers regarding DER systems, having an aggregate nameplate rating of 5 MW or less, connected in parallel to the Company’s distribution EPS. The NY SIR does not apply to DER systems larger than 5 MW. Each DER interconnection project will be individually evaluated relative to its unique technical and engineering parameters. As such, the Company reserves the right to amend or revise the technical requirements of this document, should it be justified by a project’s unique circumstances.
4. ESB 756 and this Appendix B are available on the Company’s website at <http://www.nationalgridus.com/electricalspecifications> and in printed form by contacting the Call Center in New York (see inside cover of ESB 750 for Customer Service Center telephone numbers). However, since printed copies may not reflect the latest updates, please refer to the Company’s website for the latest authorized versions.

2.0 Scope

1. This Appendix B to ESB 756 is provided to assist an Interconnection Customer (IC) desiring to interconnect a generator facility to National Grid’s EPS to meet requirements for all

¹ For wholesale (i.e., FERC jurisdictional) tariff requirements, please refer to the following New York Independent System Operator (“NYISO”) websites: http://www.nyiso.com/public/markets_operations/services/planning/documents/index.jsp?doc_s=interconnection-studies/other-interconnection-documents, http://www.nyiso.com/public/markets_operations/documents/technical_bulletins/index.jsp, and http://www.nyiso.com/public/markets_operations/documents/manuals_guides/index.jsp.

² New York State Public Service Commission (PSC or N.Y.P.S.C.).

generating interfacing equipment to be designed, installed, interconnected, tested, and operated in accordance with applicable government, industry, and Company standards.

2. These requirements are limited and apply to only those types of parallel generation and energy storage systems covered by the NY SIR connected to the Company's EPS with a nameplate rating of 5 MW or less including other distributed energy resources (DER) such as facility or campus-style microgrids, and where DER owners, or DER owners as clients of registered aggregators, sign onto a retail tariff with the intent to sell energy or ancillary services to the retail market. For FERC jurisdictional projects connected to the Company's distribution EPS, the technical provisions of this document also apply in conjunction with ESB 756 Appendix A. Where conflicts arise, the technical provisions of ESB 756 Appendix B take precedence.
3. These requirements apply only to those points in which the IC and the Company have a mutual interest in the DER facility's or premises' wiring service connection to ensure safety to the public and the Company employees as well as satisfactory operation, compatibility, and reliability with the electrical supply to others served by the Company's EPS. This includes, but is not limited to,
 - the location of the service point and facilities under the Company's exclusive control, such as the Company's metering to be installed at any point on either side of the service point;
 - service lateral;
 - service equipment; and
 - the Company's need to automatically isolate parallel sources of the DER facility from the EPS should there be an unacceptable disturbance, event, or condition within the facility.

Conditions of electric service are based on governmental laws or regulations that determine the Company's authority to provide electric service under their respective jurisdictional electricity tariffs. See 90.2(B)(5) in the National Electrical Code® and the Company's ESB 750 for more information.

4. For the Company's interconnection process requirements of the NY SIR, please refer to the retail tariff requirements at the following Company website:
NY: https://www9.nationalgridus.com/niagaramohawk/business/energyeff/4_app-pkg.asp
5. These requirements may also be applied, at the discretion of the Company, to other methods used to generate electricity in parallel with the Company's EPS not covered by the NYS Renewable Portfolio Standard (NYS RPS) and Clean Energy Standard (NYS CES), including but not limited to energy storage system (ESS) facilities, regenerative drives used in elevators, and component power inverters used in exercise equipment and any other micro scale type energy recapture systems.

3.0 Applicable Codes, Standards, and Guidelines

1. The IC's DER system shall conform to the latest revision of all local, state and federal codes and national standards that apply; including issued amendments unless the Company has taken exception to such standard. Specific codes and standards applicable to this bulletin include, but are not limited to:
 - Institute of Electrical and Electronics Engineers (IEEE) Std. 1547 "Standard for Interconnection and Interoperability of Distributed Energy Resources with Associated Electric Power Systems Interfaces"
 - Underwriters Laboratories (UL) Std. 1741 "Standard for Inverters, Converters, Controllers and Interconnection System Equipment for Use With Distributed Energy Resources"
 - ANSI/IEEE C2 "National Electrical Safety Code®" (NESC)
 - NFPA 70 "National Electrical Code®" (NEC)
 - NFPA 70B "Recommended Practice for Electrical Equipment Maintenance"

- NFPA 70E “Standard for Electrical Safety in the Workplace”
 - NETA-MTS "Maintenance Testing Specifications for Electrical Power Distribution Equipment and Systems"
2. The IC’s DER system shall also conform to any applicable requirements of the N.Y.P.S.C. or NYS Department of Public Service Staff (DPS) and any local, state, federal and/or other agencies from which a review, approval, or a permit is required.
- The minimum “fall zone” clearance of wind turbine generators (WTG) shall be in accordance with the local governmental authority having jurisdiction (AHJ) and in any case, shall not be less than 125% of maximum WTG height measured horizontally to the Company’s EPS equipment.
 - Refer to ESB 750 for additional information regarding specifications for electrical installations. The Interconnection Customer is responsible for securing and coordinating all required easements and permits for installation of equipment on the proposed site.
3. The IC shall comply with the latest revision of the appropriate Company ESB or Electricity Tariff requirements, which cover details for the customer’s electric service installation. These include:
- **ESB 750** - Specifications for Electrical Installations
 - **ESB 751** - General Requirements Above 600-volt Service³
 - **ESB 752** - Service Above 15,000 volts
 - **ESB 753** - Primary Meter Pole
 - **ESB 754** - Outdoor Pad Mounted or Vault Enclosed Single and Three Phase Transformer
 - **ESB 755** - Operation & Maintenance Requirements for Services Above 600 Volts
 - **ESB 758** - Primary Service to Metal Enclosed Gear
 - **P.S.C. No. 220** – Niagara Mohawk Power Corporation’s Electricity Rate Tariff (Electricity Tariff)
 - **P.S.C. No. 220, Rule 53** - Standard Interconnection Requirements and Application Process for New Distributed Generators 5 MW or Less Connected in Parallel to Utility Distribution Systems

Refer to **Exhibits 4** and **5** and **Figures 1** through **4** for information when submitting single-line diagrams to the Company’s electronic mail address at DistributedGenerationServices-NY@nationalgrid.com.

4.0 Definitions

See ESB 750, ESB 756, Rule 53 of the [Electricity Tariff](#), and the NY SIR for definitions of special terms. The following terms are defined for the purposes of this document.

1. **Certified:** Equipment that is approved by examination for safety; see NEC Articles 90 and 110.
2. **Certified DER:** A UL 1741 certified inverter.
3. **Distributed Energy Resource:** An energy source, either distributed generation, storage, or a combination of both, parallel connected to an area EPS
4. **Generator:** Equipment that produces power.
5. **Generator Set** or **Genset:** The singular assembly of an electrical generator and a prime mover.
6. **Line section:** Any EPS circuit segment that can be isolated via an automatic interrupting device such as a sectionalizer, recloser, or circuit breaker on three phase circuits; fuses and cut-out mounted reclosers on single phase grounded circuits.
7. **Non-certified DER:** Any induction or synchronous DER, or non-UL 1741 inverter.

³ ESB 751 Applies regardless of service voltage for DER systems.

8. **Prime Mover:** The equipment that drives the generator to output power. For example, in a typical motor operated generator, i.e., M-G set, the motor would be considered the prime mover, or for photovoltaic installations the DC panel arrays on a solar facility would be considered the prime mover.
9. **Recloser:** A line protective device having automatic interruption and controlled reclosing characteristics.
10. **Utility Grade:** Refers to protective device equipment complying with ANSI/IEEE C37.90, ANSI/IEEE C37.90.1 and ANSI/IEEE C37.90.2.

The terms Customer, distributed generator (DG), distributed resource (DR), distributed energy resource (DER), interconnection customer (IC), and isolated are defined in the **NY SIR**.

5.0 Interconnection Customer Interface Procedures

5.1 Application Process Overview

This section outlines the process for an IC to receive Company approval to interconnect DER systems to the Company's distribution EPS.⁴ This process is intended for the following:

1. New DER systems with a nameplate rating of 5 MW or less, as aggregated on the customer side of the point of common coupling (PCC), that are eligible under the NY SIR process and;
2. Review of any modifications affecting the Company's distribution EPS and service connection interface at the PCC of existing IC DER systems that:
 - (i) Have a nameplate rating of 5 MW or less as aggregated on the customer side of the PCC;
 - (ii) Are eligible under the NY SIR process; and
 - (iii) Have been connected to the Company's EPS where an existing interconnection agreement and/or power purchase agreement between the IC and the Company is in place.

This application process and its requirements do not apply to generation equipment that will never be allowed to operate in parallel with the Company's EPS. For example, this process does not apply to emergency standby generators with break-before-make transfer switches and any other generation sources that operate independently of any connection to the Company's EPS and have no provision for such connection (even for a short period of time).

Prior to applying, an IC or their agent should review National Grid's collection of maps to identify potential DG project sites. This collection of maps and information is accessible via the [National Grid System Data Portal](#).⁵ Each tab provides unique information regarding distribution level electrical circuits in National Grid's Upstate New York service territory. Users of the portal can utilize the provided information to gain insight into the current state of National Grid's electrical system in New York and get a better idea of locations that are most accommodating to the interconnection of DG. The Hosting Capacity map is one such tab that helps to identify the best locations for these types of projects. In addition, the pre-application process in the NY SIR is another tool to gather information about the utility system when considering a proposed DG site. Note that the portal and maps are not a guarantee that an IC can connect at any time and place. Several factors drive the ability and cost of interconnecting DG to the area EPS and actual interconnection requirements and costs will be determined following the NY SIR process. Studies will consider the specific project location, operating characteristics, and timing. Additionally, environmental and other required permits are independent of National Grid's interconnection process and may limit the suitability of a site.

⁴ If the Company approves an application to interconnect a DER facility to the Company's distribution EPS, the terms and conditions of that approval will be set forth in an Interconnection Agreement, which is a legally binding document that can only be changed by a written document signed by both parties. See Appendices A and H in the NY SIR.

⁵ See <https://ngrid.apps.esri.com/NGSysDataPortal/NY/index.html>.

5.1.1 Interconnection Customer Technical Data Submission

The IC shall submit, at the time of application, all relevant technical documentation as specified in the [NY SIR](#). The Company reserves the right to request additional information as needed specific to the interconnection of IC equipment including, but not limited to, three-line diagrams, control diagrams, equipment test reports and other information; see the Company's ESB 750 & 751. The Customer shall provide proof of land ownership or rights to land use.

5.1.1.1 Control Diagrams

The IC shall submit to the Company all control diagrams ("DC control schematics") of the equipment associated with the interconnection protective system. Control diagrams depict all logic used to control the interconnection protective devices. Relay logic diagrams shall be provided for utility-grade relay functions meeting utility requirements.

5.1.1.2 Interconnection Facility Equipment Data Sheets

The IC shall submit to the Company all technical data associated with the specific distribution, protection, and generation equipment included in the project. Submitted documentation shall highlight product numbers and information for the specific equipment/devices that will be installed as part of the project. Examples of required documentation specific to DERs include but are not limited to:

- Rotating machine impedance parameters for modeling
- Inverter-based system models and validation test data
- Inverter islanding detection information, including brief description of islanding detection method, parameters monitored, parameters perturbed (for active islanding methods), and whether positive feedback-based methods are to be used

5.1.1.3 Site Plan

A site plan shall be submitted showing the location of major customer equipment, the Company equipment to be installed on site, and site details that will be helpful to define accessibility of the site. The site plan shall show the following equipment at minimum:

1. Interfacing transformer(s)
2. Interrupting device(s)
3. Isolation devices(s) (e.g. generator disconnect)
4. Point of common coupling (PCC)
5. Company pole number nearest to the proposed PCC
6. Company line extension to site and from nearest Point of Interconnection
7. Existing and proposed access road(s) including, at a minimum, road material, and dimensions to confirm Company personnel and equipment access requirements are met.
8. Restricted accesses, fences, gates and access controls.
9. Generator location(s)
10. Existing service(s)

Site plans shall be to scale with approximate distances indicated, north arrow and scale bar. In addition to site plan, the Company may request an assessor survey map to determine property lines, wetlands, and easements. The customer's site plan shall indicate proposed Utility equipment or pole locations for coordination. Locations of company equipment shall be noted as: "For informational purposes only. Final location determined by Utility". Final location of Company equipment is typically determined during the design and construction phase.

5.1.1.4 Data Required for Energy Storage System Applications

For applications having ESS facilities proposed, additional information may be required at the time of application for interconnection such as but not limited to:

- Method of ESS connection whether: (1) ESS directly connected to utility EPS; (2) Distributed Generator (DG) and ESS DC coupled; (3) DG and ESS AC coupled; and (4) ESS on load side of service point and utility revenue meter with the premises load, as applicable to the proposal.
- Sequence of operation for the charging and discharging capabilities of the ESS and the maximum ramp rate in Watts/second.

Non-UL 1741 listed inverters will require a utility intertie relay with the appropriate IEEE 1547 functions, settings, and islanding protection according to the Company's [ESB 756](#) jurisdictional requirements.

5.1.1.5 Data Required for Facility or Campus-style Microgrid Applications

Additional information may be required at the time of application for interconnection specific to the facility or campus-style microgrid proposed operation. Facility or campus-style microgrid applications have certain characteristics described here, all of which fall under the U.S. Department of Energy (DOE) definition.⁶

Such microgrids consist of one or more buildings and the relationship with the connection to the Company's EPS is characterized as either a single customer-of-record or a single operating entity on one property. These can take several forms such as:

1. A single building under a common property owner with a common customer account. The microgrid has generation resources that can operate in parallel with the electric grid or in island mode.
2. A single building under a common property owner/customer, with multiple direct-metered accounts. The microgrid is configured so that all customers within the building can share the benefits of DER.
3. Multiple buildings owned by a common property owner where microgrid loads and DER are tied with common electric distribution facilities generally not owned by the Company.

These facility or campus-style microgrids are premises wiring systems governed by the NEC as adopted by the local jurisdictional authority.⁷

5.2 Interconnection Process – Non Expedited

The process for installation of those facilities the Company deems necessary for interconnection of the DER system will be specified by the Company in response to the IC's application in accordance with the [NY SIR](#). See **Exhibit 1** for Company Requirements for Projects Not Eligible for the Expedited Process.

5.3 Objectives in the Application Process

1. Parallel operation of a generator becomes integrated with the Company's EPS, in which the IC and the Company have a mutual interest. The interconnection must preserve the safety, reliability, security, power quality, and operational efficiency needs of the Company's EPS. This is necessary to ensure safety to the public and to Company employees and satisfactory operation and compatibility with the electrical supply to others. The steps and timing requirements of the application process are identified within the NY SIR.
2. Additional site-specific requirements may be indicated once the supply voltage, service arrangement, location, and generation purpose are determined, where such Customer proposed purpose can be either:

⁶ The U.S. DOE defines a microgrid as "[a] group of interconnected loads and distributed energy resources (DER) with clearly defined electrical boundaries that acts as a single controllable entity with respect to the grid [and can] connect and disconnect from the grid to enable it to operate in both grid connected and island mode."

⁷ See *NFPA 70-2017, NEC for installation requirements of premises wiring systems related to microgrids.*

- peak shaving,⁸
 - NEM, remote NEM (RNM),
 - Value Stack hourly consumption metering (e.g., eligible RNM, large on-site, and community distributed generation (CDG) projects that do not qualify for NEM or Phase One NEM, and ESS paired with an eligible generation technology), or
 - export of energy with an agreement for sales⁹ all according to the Company's Electricity Tariff provisions.
3. For new electric service or modifications to the electric service connection to accommodate the Customer's DER system, refer to the Company's latest revision of ESB No. 750, Specifications for Electrical Installations. The IC will be responsible for any permitting and conformance to the latest revision of all local, state and federal codes and national standards that apply. For example:
- Under NY Building Code requirements, the IC will need to provide evidence of electrical inspection approval from their local code enforcement agency for their premises wiring installation.
 - The IC will also be responsible for any additional costs associated with work completed by another entity (such as telephone company pole sets). The IC should be aware that project construction schedules can be severely impacted by this other work.
4. When considering a new or modified DER interconnection arrangement, the following forms in the Company's [Electricity Tariff](#) are required to be submitted to the Company as applicable:
- "Form "K" Appendix A Niagara Mohawk Power Corporation d/b/a National Grid New York State Standardized Contract for Interconnection of New Distributed Generation Units with Capacity of 5 MW or Less Connected in Parallel with Utility Distribution Systems."
 - For applications not eligible under Phase One NEM including Value Stack such as ineligible technologies or projects > 5 MW, "General Information for Connection of On-Site Generators Application for Electric Standby Service Form "G"."
5. Any subsequent sale of an On-Site Generator (OSG) facility covered by the requirements of the NY SIR will require the new owner to establish a separate interconnection agreement (Form K) for the generation with the Company and comply with these parallel generation requirements.
6. Refer to:
- The steps to install DER systems in New York as specified in the [NY SIR](#),
 - The Company's [Electricity Tariff](#),
 - The Company's Distributed Generation Services **electronic mail address** for general inquiries: DistributedGenerationServices-NY@nationalgrid.com, and
 - The Company's Distributed Generation's web site when making an application with the Company to interconnect a DER system with additional information and specific forms as follows: <https://ngus.force.com/s/>
7. The application process and attendant services are offered by the Company on a non-discriminatory basis to any IC. As part of the process, the Company may identify the need for detailed engineering studies (Coordinated Electric System Interconnection Review or

⁸ Peak shaving generation is customer-owned generation operated in parallel with the Company's EPS to reduce a customer's electrical demand. Unlike net metering, peak shaving generation, if not authorized under "behind the meter" NY ISO programs (see ESB 756 Appendix A), is not permitted to flow into the utility supply system upstream of the billing meter and will require the installation of protection devices (e.g., reverse power relays) to limit such power export onto the Company's EPS. The Company's revenue metering is detented in this case to prevent reverse billing meter registration.

⁹ An Agreement for Sales of Export Energy under a NY SIR application may be made per the Company's [Electricity Tariff](#), Service Classification No. 6, and is a Power Purchase Agreement (PPA).

CESIR), EPS upgrades and additional protection requirements. As allowed by the NY SIR and the Company's [Electricity Tariff](#), the costs of the detailed study and upgrades are the responsibility of the IC. If the IC makes significant changes in the design or installation scheduling of their DER system, then any previous information furnished by the Company to the IC is subject to review and possible change, which may cause a delay in service.

8. A CESIR presents the analysis results of the Company's interconnection study based on the proposed interconnection and service plan submission from the Interconnection Customer. The intent of the CESIR is to assess the project's feasibility, determine its impact on the utility's EPS, determine interconnection scope and installation requirements, and determine costs associated with interconnecting the Interconnection Customer's generation to the Company's EPS.
9. In accordance with the current NY SIR document, the Company will review and study the proposed Interconnection Customer's DG or ESS facility or hybrid facility project to determine:
 - if the project meets the applicable criteria considered in the CESIR process,
 - if the addition of the DG or ESS facility or hybrid facility to the Company's EPS results in any system impacts, such as relay coordination issues, changes in fault current that affect equipment ratings, voltage regulation problems, or changes to electric system operation,
 - if the DG and/or ESS facility or hybrid facility, as proposed, presents any potential to "island" existing load presently being served from the Company's EPS,
 - if the DG and/or ESS facility or hybrid facility, as proposed, can effectively re-synchronize after an outage to either the Company EPS, or an outage to the generator,
 - a good faith, detailed estimate of the total cost of completion of the interconnection of the proposed system, and the Customer's cost responsibility for the required interconnection equipment.
10. The **CESIR** does not address the Company's future operations and maintenance (O&M) associated with the Company's EPS according to the Interconnection Customer responsibilities under the NY SIR.

5.4 Special System Considerations

The Company will identify in the DER impact study any systems that may require special considerations including but not limited to those in this section.

5.4.1 Secondary Grid and Spot Network Areas

1. When applying for a DER system to be interconnected within the Company's secondary area network and secondary spot network EPS located in the downtown districts of Albany, Buffalo, Cortland, Glens Falls, Niagara Falls, Schenectady, Syracuse, Troy, Utica, or Watertown, DER system installations on distribution secondary network systems may require a study to be undertaken by the Company regardless of size, type or complexity to ensure that the DER system does not degrade the reliability, power quality, safety, or operation of the Company's network system. Therefore, customers in the downtown districts of Albany, Buffalo, Cortland, Glens Falls, Niagara Falls, Schenectady, Syracuse, Troy, Utica, or Watertown **should contact the Company at DistributedGenerationServices-NY@nationalgrid.com** to determine if the proposed location is served by a distribution secondary network system. This should be done while the DER system is still in the planning stage, and certainly before purchasing equipment or beginning installation. The Company will review the IC's plans and discuss options with the customer. Refer to attached **Exhibit 2** for area maps locating the Company's secondary network service area and the following link for more specific information

<https://ngus.force.com/s/article/ka10W00000wnRaQAI/Upstate-NY-Secondary-Area-Network-and-Secondary-Spot-Network-Maps>

2. Unlike radial distribution systems that deliver power to each customer in a single path from source to load, underground secondary area network systems deliver power to each customer through a complex and integrated system of multiple transformers and underground cables that are connected and operate in parallel; refer to attached **Exhibit 3** for more information.
 1. Connecting customer DER to the low voltage secondary networks can cause the power flow on network feeders to shift (i.e., reverse) causing network protectors within the network system to trip open. The Company's network system protection is designed without time delay. Synchronous generators are not permitted to interconnect to the Company's secondary voltage network systems. Small induction and inverter-based generators are considered on the secondary voltage network systems on a case-by-case basis.
 2. Spot networks are similar to area networks except they serve a single premise. Connection of DER systems on the spot networks are only permitted if the secondary bus is energized by more than 50% of the number of installed network protectors as required by the current version of the IEEE Std. 1547.
 3. As a result, the connection of customer DER systems on networks **(i)** poses some issues for the Company to maintain adequate voltage and worker safety and **(ii)** has the potential to cause the reverse power flow on network feeders affecting network protector operation within the network grid. Therefore, to ensure network safety and reliability additional information will be required for the Company's engineering analysis such as:
 - Customer's existing¹⁰ or proposed electric demand profile showing minimum load during peak generation time,
 - IC's expected generation profile shown for a 24-hour period and typical seven (7)-day duration based on nameplate generation rating, and
 - IC's complete electric service single-line diagram showing the configuration of the proposed generation and other metered tenants, if any, up to the service point supplied by the Company's secondary network EPS.

5.5 Interconnection Charges

ICs shall be subject to charges for interconnection costs. To permit interconnected operations with an IC, the Company may incur costs which are in excess of those it would have incurred had the customer taken standard load service. These incremental costs are directly related to the installation of those facilities the Company deems necessary for the interconnection of the DER system. They include initial engineering evaluations, purchase and installation of additional switching, transmission and distribution equipment at Company's facilities, additional safety provisions, engineering and administration. These costs shall be paid in full by the IC prior to commencement of service in accordance with the Company's [Electricity Tariff](#), and the NY SIR. For typical Company interconnection cost items expected to support those proposed DER systems not eligible for the Expedited Process as defined in the NY SIR that will be defined in a CESIR, see tables 5.5-1 and 5.5-2 which are not intended to be all inclusive. Costs will be determined according to the Company's [Electricity Tariff](#) and the NY SIR.

¹⁰ In addition, the Company may need to install recording equipment at all metered electricity users to determine the total demand of the building's network service when obtaining the service connection's electric demand profile. The cost to the Customer-Generator will be according to the Company's electric customer load survey flat rate and charged in accordance with the terms of the Company's [Electricity Tariff](#) and NY SIR.

1. Payment requirements of the CESIR estimate are outlined in the NY SIR. The Company will reconcile all charges to reflect actual cost responsibilities upon project completion. In the event final charges are greater than the CESIR estimate, the Interconnection Customer will be responsible for all final charges. In the event the final charges are lesser than the CESIR estimate, the Company will reimburse excess charges.
2. The Company's Customer Energy Integration (CEI) department shall be consulted for the Interconnection Customer's payments in accordance with the Company's Electricity Tariff.

Table 5.5-1: DER Projects Not Eligible for the Expedited Process where no EPS upgrades are expected

Item No.	Typical Company Support Activities Attributed to Interconnection Customer's Project (Requiring Charges to the Customer)	Electricity Tariff Rule References
1	Engineering acceptance review of Interconnection Customer's construction design submittals where the Company has mutual interest such as service connection facilities, meter mounting provisions, Company-designated protective devices and control schemes according to the Company's ESB 750 series.	24, 36, 37, 53
2	Revenue metering equipment changes/additions.	25, 36, 37, 53
3	Field audit of Interconnection Customer's installation to accepted design.	24, 36, 37, 53
4	Field compliance verification - witness tests of IC's protective devices coordinating with the Company's Distribution EPS.	24, 36, 37, 53
5	Project Management	53

Table 5.5-2: DER Projects Not Eligible for the Expedited Process (Complex)

Item No.	Typical Company Support Activities Attributed to Interconnection Customer's Project (Requiring Charges to the Customer)	Electricity Tariff Rule References
1	Distribution EPS upgrades (e.g., Current Limiting Fuses, Primary Conductors, Line Reclosers, Switches, Voltage Regulators, Capacitors, etc.) as a result of DER system impact.	15-18, 28, 36, 37, 53
2	Where Local EPS anti-islanding protection is required, Direct Transfer Trip (DTT) transmit addition to Distribution EPS substation feeder breaker (and/or Line Recloser) for DER system impact on distribution feeder.	28, 36, 37, 53
3	Where Company-provided Radio Communications can be applied, additions to support DTT equipment at Distribution EPS substation feeder breaker (and/or Line Recloser) for DER system impact on distribution feeder.	28, 36, 37, 53
4	Where Local EPS feeder selectivity may require prompt control measures for DER system impact on distribution feeder operations, Energy Management System Remote Terminal Unit (EMS-RTU) for status & control addition at the IC system's facility.	28, 36, 37, 53
5	Service Connection modifications and additions for DER system impact on the Company's Distribution EPS.	19-23, 28, 36, 37, 53
6	Engineering acceptance review of IC's construction design submittals where the Company has mutual interest such as service connection facilities, meter mounting provisions, Company-designated protective devices and control schemes (e.g., DTT receive package installation at DER system) according to the Company's ESB 750 series.	24, 28, 36, 37, 53
7	Revenue metering equipment changes/additions.	25, 28, 36, 37, 53
8	Field audit of IC's installation to accepted design.	24, 28, 36, 37, 53
9	Field compliance verification - witness tests of IC's protective devices coordinating with the Company's Distribution EPS.	24, 28, 36, 37, 53
10	Project Management	28, 53

6.0 Potential Issues Related to Interconnection

6.1 General Considerations

1. Customer generation connected to the distribution system can cause a variety of system impacts including steady state and transient voltage changes, harmonic distortion, and increased fault current levels. Parallel generation systems of 5 MW or less located individually on higher capacity feeders may not cause very serious impacts whereas

- those located on weaker circuits, in aggregation or in special cases (such as lightly loaded networks), can significantly impact the Company's distribution EPS.
2. A CESIR in some cases is needed to identify the severity of system impacts and the upgrades needed to avoid problems on the Company's EPS. Typically, a CESIR will be performed by the Company to determine if the proposed generation on the circuit results in any relay coordination, fault current, and/or voltage regulation problems.
 3. There is a wide range of potential issues associated with the interconnection of DER systems to the Company's EPS including, but not limited to:
 - a. Impact on step voltage regulation equipment
 - b. Increased fault duty on Company and Customer protective devices and equipment
 - c. Interference with the operation of protection systems
 - d. Harmonic distortion contributions
 - e. Voltage flicker
 - f. Ground fault over voltages
 - g. Risk of islanding
 - h. System restoration
 - i. Power system stability
 - j. System reinforcement
 - k. Metering
 - l. Arc flash
 4. It is important to scrutinize the interconnection of Customer DER facilities to the Company's EPS so that any negative impacts to the Company's EPS performance can be avoided without degradation of EPS safety and reliability. It is the intent of any Company study in accordance with the NY SIR requirements, when applicable, to avoid negative power system impacts by identifying the type of impact that will occur and determining the required equipment upgrades that can be installed to mitigate the issue(s).
 5. In general, DG facilities connected to various locations on the EPS (see Illustration 6.1.5-1) are initially evaluated for the maximum possible DER capacity under ideal situations that can be installed on the Company's EPS through technical screens in the NY SIR. Where initial technical screens identify concerns on the Company's EPS, site specific system studies (e.g., available short circuit current contributions, minimum network loading in light loading seasons, voltage regulator interactions, etc.) will be required according to the NY SIR and will identify the interconnection requirements.

Illustration 6.1.5-1: Typical DG Installation Areas on Radial Distribution Feeders

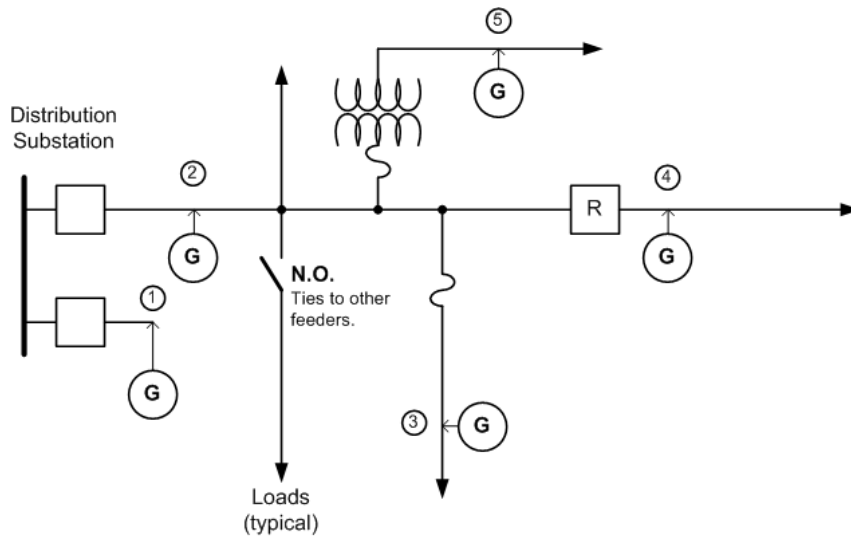

“O” - DG Interconnection Location Point on Feeder

1. Express (dedicated) radial feeder
 2. Feeder Main
 3. Feeder Branch protected by fuse
 4. Sectionalized Feeder Main
 5. Feeder Branch protected by fuse with ratio transformer
6. DER saturation, such that it becomes technically infeasible to operate on the distribution feeder or line section becomes problematic when multiple proposed projects or additional proposed projects are submitted in excess of major EPS infrastructure. The Company will identify DER saturation in preliminary screening reviews and in the results of impact studies for DER applications. Studies will be more complex and accommodating interconnections will likely require more involved infrastructure development, costs, and duration to construct.
 1. On single-phase radial distribution systems, generator interconnections with aggregate generator nameplate ratings over 50 kVA may require three-phase service and will be determined by the Company on a case-by-case basis.
 2. The EPS substation bus voltage regulation, transformer capacity, and high voltage side protection may be impacted by large DER systems and the Company may specify interconnection to a higher voltage EPS.
 7. The Company's substations are subject to fault duty limitations. Adding generation to the Company's EPS increases the amount of fault current imposed on the substations and equipment located on the feeder(s). Exceeding the fault duties of equipment and devices at the substation(s) and on the feeder(s) as a result of DER systems will not be permitted and alternate methods of interconnection shall be explored or the replacement at the expense of the IC of "overduty" equipment and devices with the appropriate ratings and of the Company's standard design where this limit has been reached.
 8. Normally, one service is provided to the customer according to the Company's Electricity Tariff, N.Y.P.S.C. No. 220. However, under specified conditions, multiple service facilities may be supplied to the Customer from a Company Distribution EPS. The interconnection of multiple services shall be specified by the Company within the Company's operating practices and electric service requirements.¹¹

6.2 Significant EPS Considerations

6.2.1 Direct Transfer Trip

¹¹ See Section 3 in the Company's ESB 750 for more information on multiple service requests.

IEEE 1547 requires any DER on a distribution feeder to detect and be tripped offline within two (2) seconds upon formation of an island from the area EPS. *An island is a condition in which a portion of an area EPS is energized solely by one or more Local DERs while it is electrically separated from the rest of the area EPS.* There are some cases where a DER's on-site equipment (such as voltage and frequency relaying or islanding detection) cannot reliably detect utility islands. Where the Company determines that a significant risk of islanding exists, DTT may be required. DTT typically requires utility substation modifications to send a signal to trip the DER facility offline when the substation breaker opens. This also typically requires the Customer to lease a communication medium between the substation and the DER facility, as well as install a receiver and tripping device in their facility. DTT has inherent high costs and physical limitations associated with equipment installation due to the typical leased telecommunication line requirement at the EPS source and at the generator(s), as well as required utility substation modifications. The initial and recurring costs for DTT are at the expense of the Interconnection Customer. See section 7.6.12 for more detail on when DTT may be required, which includes but is not limited to islanding

6.2.2 Transmission Ground Fault Detection

The addition of generation sources to distribution feeders can result in the backfeeding of the substation transformers, effectively turning a station originally designed for load into a generation step-up transformer. The Company's most common distribution substation transformer is ungrounded on the transmission side. Due to the transformer's configuration,¹² it cannot contribute zero sequence ground fault current to single line to ground faults on a transmission line, and the voltage on the unfaulted phases rises significantly and rapidly. These over voltages have the potential to exceed insulation levels of the station and transmission line equipment, and maximum continuous operating voltage of surge arresters. This situation can also leave transmission ground faults energized by the distribution-connected DER. Zero sequence voltage protection (commonly referred to as "3V₀") on the primary side of the transformer is required to detect these overvoltage conditions. This 3V₀ protection will disconnect the generation from the substation transformer and stop the generation and transformer from contributing to the transmission-side overvoltage condition.

If the Company determines there is a likelihood of a zero sequence overvoltage event, transmission ground fault detection equipment and substation modifications may be required.

Illustration 6.2.2-1: Simple One Line for Transmission Ground Faults for Typical Substation Transformer Configuration

¹² A common substation transformer configuration is delta on the transmission side and wye-grounded on the distribution side. There are other transformer configurations for which zero sequence continuity is broken and/or the DER is unable to reliably detect and trip offline for transmission ground faults. The Company determines when and which type of transmission ground fault detection is required based on the substation configuration on a case-by-case basis.

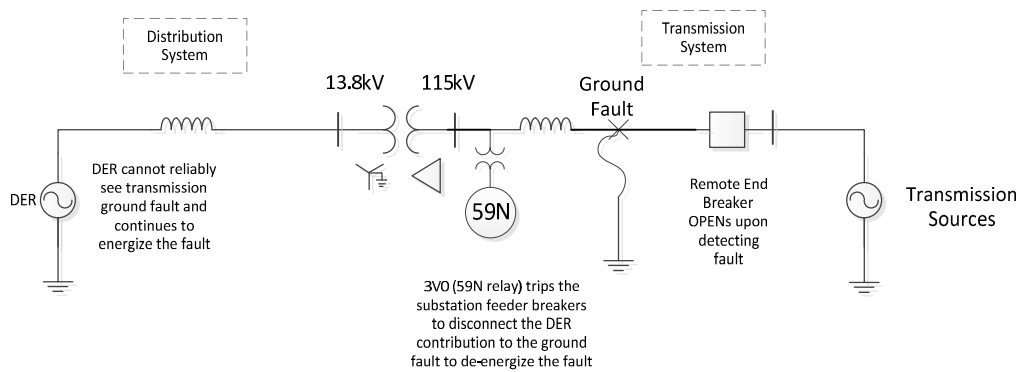

Illustration 6.2.2-1 shows an example transformer configuration for which it is difficult for distribution-connected DERs to detect and trip for transmission ground faults. Where the DER can contribute to this condition without tripping on the 88% undervoltage trip point, $3V_0$ may be required to be installed at the substation. Three voltage sensors (typically coupling capacitor voltage transformers (CCVT), are connected to the transmission side of the utility substation transformer. These voltage sensors are wired to a 59N relay (“ $3V_0$ ” or “zero sequence overvoltage” function), which trips the DER offline via utility breakers in the substation. This helps de-energize the ground fault from all sources. (Not all details or configurations are shown. Some substations may require protection for detecting transmission ground faults other than $3V_0$, such as scheme modifications, transformer replacement, or teleprotection systems). Customers should be aware that these modifications to the Company’s substations require significant cost and time to install. The cost and time requirements are provided in the CESIR according to the NY SIR and the Company’s Electricity Tariff when performed for the Interconnection Customer.

7.0 General Design and Operating Requirements

From the perspective of interconnection, there are three main types of customer generation systems that interface to the EPS. These include:

- Induction Generators
- Static Power Converters (inverter-based)
- Synchronous Generators

Each type has its own specific characteristics regarding synchronization equipment, protective functions, starting practices, and electrical operating behavior. There may also be additional specific requirements that may be identified as part of any CESIR that is performed for a specific DER system and/or location. For the purposes of this bulletin, any reference to DER ratings herein refers to the nameplate rating of the generation facility.

- For inverter-based generation, this shall refer to the nameplate rating of the inverter(s). De-rating of inverter-based DER shall only be considered if the equipment is provided by the IC’s manufacturer with a permanent means of reducing the rated output, and so marked with an equipment nameplate stating the de-rated output.
- For rotating machines, this shall refer to the nameplate rating of the electric generator (as opposed to the nameplate rating of the generator-set or prime mover). De-rating of rotating machine generators by their prime mover capabilities shall not be permitted.
- Equipment nameplates shall meet ANSI standards. De-rating of DER facility equipment shall be evaluated on a case-by-case basis, with consideration given to specific project conditions, and will be accepted at the sole discretion of the Company.

For facility or campus-style microgrid connections, DER interconnection equipment, protective systems and microgrid controllers connected at the PCC to the Company’s EPS are to be designed and operated according to the Company’s requirements and specifications as well as

to applicable codes and industry standards. Facility or campus-style microgrids may be permitted to automatically trip their PCC isolation device to island and serve the premises load; however, this device is required to be blocked from closing until authorized to do so by the Company. The control scheme that will disconnect and reconnect the facility or campus-style microgrid from the Company's EPS must be reviewed and approved by the Company through the NY SIR process and is subject to witness testing and/or periodic testing as necessary. These situations will require that specific operating protocols to ensure that customer safety and the overall EPS safety and reliability are not in any way compromised.

7.1 General Criteria

The interconnection of all DER systems in parallel with the Company's EPS requires safeguards for synchronization and back feed situations in accordance with the NY SIR. Each specific connection must be studied with respect to size, type, and the nature of the EPS at the interconnection point. Only the results of a specific study can indicate the suitability of a given DER system connection to the Company's EPS and its possible economic viability. See Rule 53 of the [Electricity Tariff](#) and the [NY SIR](#) for detailed requirements.

7.1.1 Delivery Voltage

The Company will designate the type of service and delivery voltage based on the location of the Customer and the size and characteristics of its proposed DER.

7.1.2 Single Phase

Single-phase DER system connections to the Company's EPS under 600 volts present power quality and phase balance challenges. Single-phase connections shall have these minimum characteristics:

- Nameplate rating of a single generator or group of generators equal to or less than 50 kVA unless otherwise specified by the Company on a case-by-case basis.
- Configured as a three-wire, line-to-line with neutral, or line-to-neutral with adequate load balance.
- A dedicated service lateral with a dedicated transformer, when required by the Company.

7.1.3 Three Phase

Other than permissible single-phase connections, three-phase connections are required. The aggregated nameplate rating of all DER systems operating in parallel with the Company's EPS on the premise shall not exceed 5 MW per the requirements of the NY SIR. For greater than 5 MW and networked subtransmission and transmission applications, refer to ESB 756 Appendix A.

7.1.4 Phase Balance and Voltage Tolerance

1. The IC's DER facility shall permit equal current in each phase conductor at the service point or PCC. Voltage unbalance resulting from unbalanced currents shall not exceed 2% and shall not cause objectionable effects upon or interfere with the operation of the Company's facilities and service to others. This criterion shall be met with and without generation.
2. The interconnection of the DER facility shall not affect the Company's nominal voltage delivery at the PCC by greater than 3%.

7.1.5 Neutral Stabilization, Ground Fault, and Grounding

It is the Customer's responsibility to detect and trip the facility for ground faults on the Company's distribution EPS

1. An effectively grounded system with respect to the Company's EPS must be provided to ensure neutral stability, facilitate ground fault detection, and avoid distribution circuit over voltage during accidental isolation of the Company's area EPS from the Company's main system. This may require an additional ground source (see Section 7.3 for acceptable effective grounding options).

2. Contributing to ground faults on the Company's distribution EPS can desensitize the relays at the Company's substation. The effects of such grounding on the Company's ground-relay sensitivity shall be limited. The Company requires ground fault protection on any system that can be a generation source and to protect transformers that can be paralleled and supplied from two sources. When generator tripping is needed to sense ground faults on the Company's distribution EPS:
 - The winding arrangement of the Customer's generation facility transformer and the generator winding shall be such that the Company's system remains effectively grounded (see Section 7.3).
 - The Company may require that grounding impedance be limited to the highest value suitable for neutral stabilization, or to limit generator ground fault contributions. Contribution to the faults on the Company's distribution EPS can desensitize the relays upstream of the IC's interconnection. For that reason, it is required that the IC provide a means to install a grounding reactor/resistor within their facility to limit the ground fault current. Where possible, the ground fault current shall be limited to three times the generator rating and limit the rise of ground fault current at the point on the high voltage (primary) level nearest the proposed service point by no more than 10%. The grounding reactor/resistor shall not violate the effectively grounded system requirements. The impedance of the grounding reactor/resistor will be specified by the Company. If the 10% criterion is not met with the grounding impedance, other methods, upon Company acceptance may be required by the IC to mitigate the increase in fault current.
3. Distribution circuits may have unbalanced loads (i.e. single-phase loads) which result in neutral currents on equipment connected to multi-grounded circuits. Customers installing grounding equipment (i.e. grounding reactors, grounding transformers) are encouraged to consider this unbalance current when designing neutral-connected equipment where there is no transformer isolation from the Company's EPS. The Company recommends the Customer consider a minimum 100A continuous current rating (or the actual unbalance current, whichever is greater) for 15kV class-connected grounding reactors, and similar equipment parameters for other voltages.

Non-effectively grounded area EPS:

Where the IC is permitted to interconnect through an un-grounded source, a 59N (3V₀) scheme may be required on the primary (utility) side of the accepted ungrounded source (ungrounded transformer serving the DER system, or generator as applicable) (see Figure 4) to detect utility-side ground faults. supplying the DER system. Refer to Section 7.3.1 for further discussion on service transformer requirements.

7.2 Service Equipment and Revenue Metering

7.2.1 Service Equipment Requirements

1. The IC shall provide service entrance equipment as a part of their installation; see the Company's ESB 750. The IC's service equipment shall be rated, at a minimum, for the maximum fault current available from the Company's EPS and their own contribution from the generator(s), motors, etc.
2. Marking: The IC shall install and maintain clearly marked permanent labels in accordance with the NEC, NY SIR and the Company's applicable ESB series requirements. All Utility required marking shall be preprinted or engraved (no hand marking), have a minimum 5-year warranty for indoor or sheltered applications and have a minimum of 25-year warranty for use in outdoor applications. Labels shall be replaced when they no longer meet the legibility requirements of ANSI Z535.4. Labels shall be UL969 compliant. Materials used shall be weather resistant, UV stabilized and suitable for the environment where it is installed. Labels may be of engraved plastic, metallic foil, or polymer plastic mechanically or adhesive applied. For labels using adhesive, ultra-

high strength bond adhesive shall be required. Data sheets shall be provided to indicate compliance with labeling requirements.

Exception: Residential installations \leq 25kW with feed-through type meters may have labels with a minimum 5-year warranty regardless of location.

In addition to NEC required marking, the following Utility requirements apply:

- The utility meter enclosure shall be labeled with the following: “WARNING: DUAL POWER SOURCES”
- The utility meter sockets shall be labeled as follows, where applicable:
 - Utility Service Meter, Utility DER Sub-Meter, where “DER Type” shall be designated by generation type as follows: “PV Generation” or other type Generation as required per Tariff, or Storage
- The Interconnecting Customer’s AC utility disconnect switch shall be labeled “GENERATOR DISCONNECT”.
 - If the AC utility disconnect switch is not adjacent to the meter and/or PCC, the Interconnecting Customer shall provide marking as to the location of the switch.
- All Interconnecting Customer-Owned meters shall be labeled “CUSTOMER-OWNED METER”

3. For large DER Customers with aggregate generation equal to or greater than 500 kW, refer to the typical primary overhead service configuration requirements in **Exhibit 5**.
4. For situations where a higher voltage service connection is required, refer to the Company’s ESB 752, 753, or 758 as applicable.

7.2.2 Company Revenue Metering Requirements

1. The Company will specify the location and arrangement of all equipment required for the revenue metering of the IC’s service and DER facility as well as the monitoring of compliance with all applicable laws, regulations, interconnection agreements, and power purchase agreements. Reference the Company’s ESB 750, Section 7 for additional information and requirements. The NY SIR and Rule 53 of the [Electricity Tariff](#) describe qualifications for net metering. Where NEM does not apply, the Company’s revenue metering will have multiple channels for power delivered and received for power purchase agreements (PPA) or be detented¹³ for parallel import connections to prevent reverse billing meter registration. When applicable, credit metering will be installed if arrangements have been made for energy sales to the Company under a PPA; see Service Classification No. 6 of the [Electricity Tariff](#).
2. ICs may be required to provide a telecommunication line to each Company-owned revenue meter location. This telecommunication line would only be required in the event a cellular signal was not sufficient to provide reliable service for standard revenue meter reporting. The telephone line shall be capable of direct inward dial without human intervention or interference from other devices such as facsimile machines, etc. The Company will make the final determination of any customer proposed alternate telecommunications service for Company-owned revenue metering, if any, for the specific Customer’s DER system installation.
3. For fully rated meter installations, the DER source connection shall terminate to the lugs at the bottom of the meter socket. The Utility side connection shall terminate to the lugs at the top of the meter socket.

¹³ “Detented metering” is measuring and registering power flow in a single direction by either mechanical, or electronic, or programming means in a revenue meter.

7.2.2.1 ESS paired with DG

ESS paired with DG projects may require a separate meter for ESS and DG metering. Meters for separate DER are installed at the IC's expense. Metering configurations and arrangements may vary based on specific installations. See the Company's ESB 750 (<https://www.nationalgridus.com/ProNet/Technical-Resources/Electric-Specifications>) for service and sub-metering installation requirements.

7.2.3 Company Revenue Metering Requirements for VDER of Paired ESS plus Renewable DG

Company-owned revenue meters are required at the PCC, renewable DG, and ESS in the DER facility at the IC's expense for paired ESS and renewable DG projects applicable to NY value of DER (VDER) of the Company's Electricity Tariff.

7.3 Transformer

7.3.1 Secondary Served Customers

Where the Company provides secondary service, the Company's transformer is standard for service delivery voltages offered in the Company's [Electricity Tariff](#); see Section 3 in [ESB 750](#). Maximum transformer size the Company will supply for a new secondary connected DER connection is 500 kVA where the non-DER premises electricity use is 500 kVA or less. Non-standard transformers will not be provided by the Company. The Company will determine when dedicated services and a dedicated transformer are required in order to reduce the impact on other adjacent customers. The need for a dedicated transformer(s) may be determined at any point in the IC's DER facility's life cycle. If a dedicated transformer(s) is required, the IC will be advised by the Company in writing. The cost of the transformer(s) will be the responsibility of the IC according to the [Electricity Tariff](#) and as permitted by the NY SIR. DER facilities proposed on the customer side of an existing Company-owned transformer may require the existing transformer service to be replaced under the following typical conditions, although not all inclusive:

1. DER exceeds the Company's transformer nameplate ratings.
2. Interconnection of DER to the customer side of the transformer creates undesirable effects on the Company's EPS.
3. Transformer is a non-standard design no longer provided by the Company's standard (see ESB 750 for standard service voltages) to meet the power quality, safety, and/or reliability to the individual customer, or the EPS.
4. Existing transformer configuration is such that an additional primary side protection scheme is needed for the DER facility to detect and trip the generation source for faults on the Company's EPS that requires the IC to have primary service.

7.3.2 Primary and Higher Voltage Served Customers

The Company reserves the right to specify the winding connections for the IC's interconnect transformer between the Company's delivery point and the IC's DER system output terminals as well as whether it is to be grounded or ungrounded. The IC shall provide their interconnection transformer's specifications and ratings for the Company's review and acceptance in the CESIR process.

7.3.2.1 Effectively Grounded, Four-wire Multi-grounded 3-phase Wye EPS:

To avoid overvoltage on the distribution EPS and other customers, the Company's policy requires any DER facility 500 kW and above connected to a four-wire multi-grounded distribution feeder to provide an effectively grounded system with respect to the Company's EPS. Refer to Section 7.1.4 for specific grounding requirements.

The IC's DER facility shall be designed such that it cannot connect to the Company's EPS without the means of effective grounding in service. In all instances, when the means of effective grounding is out of service or disconnected from the system, the DER facility shall be disconnected from the Company's EPS.

Any DER or aggregate DER below 500 kW in an IC's facility may be permitted to utilize an ungrounded interconnection. The Company reserves the right to require an effectively grounded source for generation at 250 kW and above depending on DER saturation and other conditions on individual distribution EPS feeders.

Effective grounding may be accomplished with the following configurations:

1. A wye-grounded to wye-grounded transformer with a grounded generator source. A neutral grounding reactor or grounding resistor between the generator neutral and ground may be required in event the generator's contribution to faults on the Company's EPS results in undesirable fault current values. See section 7.1.5.
2. A wye-grounded connected primary winding with a fully insulated neutral and a delta connected secondary winding. The insulated neutral is to establish provisions for the addition of a grounding reactor or grounding resistor in the event the generator's contribution to faults on the Company's EPS results in undesirable fault current values. See section 7.1.5.
3. A wye-grounded to wye-grounded transformer with an associated grounding transformer.
4. An ungrounded primary winding with a primary side grounding transformer and having any secondary configuration.
5. A wye-grounded primary with wye-ungrounded secondary with a primary side grounding transformer.

7.3.2.2 Not Effectively Grounded, Three-wire 3-phase EPS:

On three-phase Company EPS circuits other than effectively grounded, only the connection of ungrounded primary interface transformers shall be permitted. A delta primary is normally required.

7.4 Manual Generator Disconnecting Means

The IC's DER facility shall have a load break disconnect switch accessible at all times to the Company to electrically isolate the Company's distribution EPS from the customer's DER system. The Customer shall provide direct 24/7 unencumbered access to the disconnecting switch to allow Company personnel to operate the disconnecting switch and apply protective grounds as needed, without the need to contact the Customer. The Company will make efforts whenever possible to notify the IC should the DER facility need to be de-activated; however, the Company reserves the right to operate the DER facility's disconnect directly in emergency situations. Refer to section II. B. Operating Requirements of the SIR for additional information.

The IC shall provide contact information for their qualified personnel that can be reached 24/7, should complications arise with access to the IC's equipment. Should there be any complications with Company access to the DER facility's disconnecting device, the Company reserves the right to disconnect the IC's service in its entirety by the next upstream Company-owned isolation means when necessary.

The disconnecting means shall have the following characteristics:

1. **Rating:** Disconnecting means shall be rated to interrupt the maximum generator output; meet applicable UL, ANSI, and IEEE standards, and shall be installed to meet the NEC and all applicable local, state, and federal codes.

2. **Arrangement:** The disconnect switch shall be installed to have the line connection (i.e., jaw side) of the switch connected to the utility source. Hinge side of switch shall be connected electrically towards the customer DER. Disconnects with more than one current carrying conductor shall be gang operated.
3. **Type:**
 1. The type of disconnecting means for all DER is subject to Company approval.
 2. For DER systems that are connected directly to the area EPS requiring a manual disconnecting means at the PCC that can be opened for isolation, the device shall be a gang-operated, blade-type switch. Pull-out switches or blocks are not permitted for this application. In accordance with the Company's safety rules and practices, this isolation device must be used to establish a visually open, working clearance boundary when performing maintenance and repair work. The visual open must be observable without opening the equipment.
 3. For DER systems connected directly to a Customer's building distribution system downstream of the PCC requiring a manual disconnecting means for isolation of the DER, the disconnecting means may be a draw out circuit breaker, disconnect, or comparable device mutually agreed upon by the Company and the Customer. For installations above 600 V, the visual open of all three phases shall be capable of being observed without opening the equipment. Site-specific technical requirements will be considered by the Company if permitted to grant draw-out breakers with the provision for padlocking at the draw-out position, above 600 V or with a full load output of greater than 960 A, that are proposed to meet these isolation requirements. If the Company grants such use, the IC will be required, upon the Company's request, to provide qualified operating personnel to open the draw-out circuit breaker and ensure isolation of the DER system, with such operation to be witnessed by the Company followed immediately by the Company locking the device to prevent re-energization. In an emergency or outage situation, where there is no access to the draw-out breaker or no qualified personnel, the Company may disconnect the electric service to the premise to isolate the DER system.
4. **Location:**
 1. The location of the disconnecting means shall comply with Company standards for working clearances, access road construction, vegetation management, and other similar requirements to ensure adequate access for Company personnel and equipment.
 2. The location of the DER facility disconnecting means for all DER projects is subject to Company acceptance on a case by case basis. This shall comply with Company standards for working clearances, access road construction, vegetation management, and other similar requirements to ensure adequate access for Company operating personnel and equipment.
 3. The location for the disconnecting means for all DER projects is subject to Company approval on a case by case basis.
5. **Access and Locks:**
 1. The disconnecting means must be readily accessible at all times to the Company to electrically isolate the Company's Distribution EPS from the Customer's generator facilities. The designated generator disconnect also must be accessible and lockable in the open position and have provisions for both Company and IC padlocks.
 2. Should the disconnecting means be located behind the IC's locked gate, double locking is required, where both the Company's and IC's locks would be employed.
6. **Identification:** All required disconnecting means shall be identified by a permanent label as required by the NEC, the NY SIR and ESB 750.

Exception:

In accordance with the NY SIR and the Company's electric service requirements in ESB 750, inverter-based DER systems 25 kW and below are not required to have a separate manual generator disconnect switch if the unit has a disconnecting means integrated into the design and meets the requirements of the NEC.

- a. For systems 25 kW and below, a disconnecting or isolation means shall be required to be located between the Company meter and the DER device to allow for Company meter installation and testing. This device may be located based on customer preference, although where this device is not accessible to the Company, this may cause delay with associated meter installation and testing.

7.5 Generator Interrupting Device Requirements

7.5.1 General

1. For any aggregate generation connected to a common feeder that is 500 kW and greater, an interconnection interrupting device such as a circuit breaker shall be installed at the Customer's site. The 500 kW criteria is intended to encompass individual sites that are comprised of multiple smaller generators, totaling 500 kW or greater. It is also intended to encompass generation located at multiple sites that total 500 kW. Due to the unique circumstances of each individual installation, the Company reserves the right to require an interrupting device if necessary. As such, interrupting devices may be required for projects below 500 kW, if the project warrants the installation. The Company may elect to waive this requirement if all Company protective and interrupting requirements are met by a Company device at the facility.
2. The generator interrupting device shall be designed to ensure the interrupting of the DER system upon loss of interrupting device supply power, or upon loss of local power supply source.
3. When a local power supply source is utilized, generator interconnection interrupting devices shall have DC trip coils and tripping energy.
4. For primary wye grounded – secondary delta, and for primary delta interconnection transformers, the interrupting device shall be installed on the high voltage side. If there is more than one interconnection transformer, this requirement applies to each one individually. The interconnection interrupting device shall be capable of interrupting the current produced when the DER facility is connected out of phase with the Company's EPS.
5. The interrupting device shall be located upstream (closer to the Company's source) of the generation and any grounding transformer(s), so that it is capable of disconnecting the fault current contributions of the generation and grounding transformer.

7.5.2 Local Power Supply Requirements

When a continuous local power supply is proposed to comply with the Company's protection element operational requirements to safely remove the generation from the EPS the following conditions shall be met:

1. Failure of an uninterruptible power supply (UPS) rectifier shall not inhibit relay power supply and operation from the local power supply.
2. A fail-safe alarm contact shall be incorporated into the control trip scheme of the generator main interrupting device for loss of local power supply charge source.

3. The local power supply shall be sized to ensure successful operation of generator interrupting device upon loss of charge source. This supply shall be capable of providing all power requirements to initiate and complete the entire operating process of tripping the interconnection interrupting device.
4. The local power supply system shall be hard-wired and permanently installed. Portable cord-and-plug devices are prohibited.
5. System design calculations in accordance with IEEE standards and other industry standards as applicable shall be provided by the IC for supply voltage, capacity specifications, and charging system provisions and are subject to the Company's review and acceptance.
6. Control circuits associated with protective relays shall be DC powered from a battery and battery charger system. Solid state relays shall be self-powered or DC powered from a battery and battery charger system.
7. If the DER facility uses a non-latching interconnection contactor, AC powered relaying may be permitted provided the relay as well as its method of application are fail-safe, meaning that if the relay fails or if the voltage and/or frequency of its AC power source deviate from the relay's design requirements for power, the relay or a separate fail-safe power monitoring relay will immediately trip the generator by opening the coil circuit of the interconnection contactor after a maximum 2 second time delay.

7.6 Protection and Protective Equipment Requirements

The Interconnection Customer is solely responsible for the protection of their DER and premise equipment, including any customer equipment required by the Company to interconnect to the area EPS. The Interconnection Customer is also required to provide electrical equipment and relays with ranges and rating that will allow proper DER and premise relay system coordination with Company protection systems. Coordination margins and parameters will be determined by the Company.

The protection system shall be designed with interlocks and protective functions to ensure that there is proper voltage, frequency and phase angle conditions between the Company's EPS before the DER system is permitted to parallel. The IC is responsible for voltage excursion detection and the detection of three-phase, line-to-line, and line-to-ground faults on the Company's EPS as well as faults on the IC's system that cause overcurrent conditions on the Company's EPS.

For the purpose of evaluating fault current, short circuit protection, and protective relay settings, current values are based on the full Volt-Ampere (VA) nameplate rating of the equipment, which may be greater than the kW rating of the equipment. For ESS, all protection reviews, regardless of any on-site operational limitations, are performed at the sum of the nameplate ratings of the ESS and any paired DG since fault currents are related to the full kVA nameplate ratings of the inverter(s) and/or generators used.

The Company may specify values within the allowable ranges of IEEE 1547 subject to the limitations on voltage and frequency trip settings specified by the regional reliability coordinator that consider bulk power system impacts of affected aggregate DER capacity. Where Regional ISO voltage and frequency requirements apply, the IC shall refer to the Company's ESB 756 Appendix A for specific requirements related to North American Electric Reliability Corporation (NERC) Protection and Control (PRC) standards.¹⁴

¹⁴ See <https://www.nerc.com/pa/Stand/Pages/ReliabilityStandards.aspx> and <https://www.nerc.com/pa/stand/Pages/ReliabilityStandardsUnitedStates.aspx?jurisdiction=United%20States>.

7.6.1 Type Tested (Certified) Equipment

Protective equipment that has been type tested and recognized by the NY SIR will be permitted. See the NYS DPS' list of certified interconnection equipment on their website at: <http://www3.dps.ny.gov/W/PSCWeb.nsf/All/DCF68EFCA391AD6085257687006F396B?OpenDocument>. The IC shall follow the testing requirements as outlined in Rule 53 of the [Electricity Tariff](#) and the [NY SIR](#). Refer to Exhibit 6 for a guide for the Company's witness for verifying a type tested net-metered DER system's operational compliance.

7.6.2 Non-Type Tested Equipment

Protective equipment that has not been type tested per the NY SIR will be permitted with the implementation of utility grade protective devices acceptable to the Company. The use of utility grade relays¹⁵ is subject to prior Company review and acceptance per section 7.6.3.2.

7.6.3 Number of Relays Required

For all DER facilities 500 kW and greater, redundant relaying is required for the detection of Area EPS faults & disturbances. Relays are considered redundant only when two utility grade relays with identical protective functions are provided.

Where relay performance may affect the operation of the Company's EPS at service voltages less than 15 kV, a single utility grade microprocessor-based relay along with a Company approved scheme, where relay failure automatically trips the associated breaker(s), may be acceptable. The utility grade relay failure alarm shall be wired to trip and block close the Company-designated generator interrupting device. Auxiliary relays, where used, shall be fail safe and utility grade. If two utility grade relays are used to provide redundancy, and neither relay can perform the intended protection functions the protection scheme shall trip and block close the interrupting device.

7.6.3.1 Certified Inverter-based Energy Resource Protection Requirements

IEEE 1547 compliant and UL-1741 certified¹⁶ inverters shall be equipped with an internal active anti-islanding scheme, under voltage (27), over voltage (59), under frequency (81U) and over frequency (81O) relays. Inverter based generators shall be in compliance with the latest version of IEEE 1547 and its amendments ("IEEE 1547"). The IC shall provide the voltage and frequency ride through capabilities as specified in IEEE 1547 Category II in any inverters installed as part of a DER facility proposed to interconnect to the Company's EPS. The voltage regulation capabilities shall be turned OFF unless otherwise required by the Company. See section 7.8 for further inverter function requirements.

7.6.3.1.1 Certified Inverter-based Energy Resources below 500 kW

If the inverter(s) are IEEE 1547 compliant and UL-1741 listed in the configuration proposed for interconnection, the internal relays are considered as the only required protection and an additional utility grade relay is not required to be installed. At the Company's sole discretion, the Company reserves the right to require a utility grade relay for systems above 300 kW with, at minimum, functions 27, 59, 81U/O enabled.

7.6.3.1.2 Inverter-based Energy Resources 500 kW or Above

For inverters that are IEEE 1547 compliant and UL-1741 listed in the configuration proposed for interconnection, inverter internal relay functions are considered as primary protection. The Company requires one additional utility grade relay to be installed as secondary protection for inverter-based solar PV generation 500 kW and above. The 27, 59, 81U/O, and 51N or 51G elements shall be activated in the utility grade protection relay. On circuits where generation is permitted to connect as an ungrounded source, a

¹⁵ See definition of "utility grade" for protective device equipment in Section 4.

¹⁶ See definition for "certified" in Section 4.

59N relay function is required to detect ground faults on the utility. Where Company-required functions are not redundant, such as overcurrent or 59N functions, refer to section 7.6.3 for fail-safe tripping requirements.

7.6.3.2 Non-Certified Energy Resource Protection Requirements

Where Company-required functions are not redundant, such as overcurrent or 59N functions, refer to section 7.6.3 for fail-safe tripping requirements.

7.6.3.2.1 Energy Resources below 500 kW

For any non-certified generators less than 500 kW one utility grade relay installed as primary protection is required. At minimum the 27, 59, and 81 U/O shall be active in the utility grade relay. For all systems 300 kW or larger, the Company reserves the right to require redundant utility grade relaying.

7.6.3.2.2 Energy Resources 500 kW and greater

For any non-certified generator 500 kW and greater two utility grade relays are required to be installed with 27, 59, 81 U/O, and overcurrent elements for both phase and ground. On circuits where generation is permitted to connect as an ungrounded source, a 59N relay function is required to detect ground faults on the area EPS.

7.6.4 Instrument Transformers for Protective Device Relays

7.6.4.1 Current Transformers (CT)

CT ratios and accuracy classes shall be chosen such that secondary current is less than or equal to 5 amperes under normal operation and 100 amperes under maximum fault conditions. For the primary wye grounded – secondary delta installations, the CTs shall be installed on the primary voltage side. If the interconnection transformer is primary wye grounded – secondary wye grounded, the CTs can be installed on either the primary or secondary voltage side, provided the CTs sense the current contribution to Company EPS faults from ground sources installed on the facility. CT accuracy and burden calculations shall be provided for review by the Company. Meter selector switches shall not be connected into the secondary circuits of current transformers used with protective relays specified by the Company.

7.6.4.2 Voltage Transformers (VT) and Connections

Voltage sensing is required on all three phases on the utility side of the interrupting device. VTs for voltage sensing shall be configured wye-grounded (Yg-Yg) for effectively grounded circuits. Voltage measurements shall have no more than 2% error under the expected ambient temperature range (-10°C (14°F) to +45°C (113°F)) and no higher than 4% error under all operating temperatures (-40°C (-40°F) to +65°C (149°F)). If the secondary voltages can be used to detect voltage depressions for faults that occur on the Company's EPS, and the secondary voltage is within the relay's acceptable operating range, a direct voltage connection may be acceptable and VTs may not be required. The use of Yg-broken Delta VTs will be considered by the Company on a case-by-case basis.

7.6.5 Protective Relay and Trip Circuit Hard-Wire Requirements

Unless authorized otherwise by the Company, protective relays shall be hardwired to the device they are tripping. Interposing computer-based or programmable logic controllers, auxiliary modules, or the like are prohibited in the trip control scheme between the relay and the device being tripped. Trip circuits shall not be fused.

The use of interposing relays is subject to approval by the Company. Interposing relays, if proposed, shall be utility grade, and the tripping scheme shall be fail-safe.

Generator protective relays shall be located no greater than 30 feet from the device in which they control.

7.6.6 Protective Relay Test Switch Requirements

Microprocessor and non-draw out relays, including 86 lockout relay functions, shall have ABB FT-1, or equivalent, test switches isolating all inputs and outputs of the relay. All

test switches shall be labeled for the associated relay functions. DC inputs or outputs are not permitted on AC test switches.

- **AC Inputs:** Each relay shall have its own AC test switch.
- **DC Inputs and Outputs:**
 - For relays designated by the Company it is required that each individual relay have its own DC test switch that isolates the positive and negative DC for each input and output.
 - For relays required to protect the IC's equipment, it is required that each relay have its own DC test switch for inputs and outputs. For ease of maintenance testing and troubleshooting, it is required to isolate the positive and negative DC of the input and output.
- Groups of relays that protect the same piece of equipment, such as a transformer or a feeder, may share a DC test switch under the following conditions:
 - The individual blades of the test switch shall be grouped by relay.
 - A permanent label shall be affixed to the relay panel identifying the use of each blade.

Exception: Where the relay inputs are supplied by a control cable (such as a some recloser installations) and the relay test set uses a control cable that inputs to the same port in the recloser control enclosure, test switches may not be required.

7.6.7 Voltage Relay Devices

Over and under voltage relays shall meet IEEE 1547 requirements including capability for under/over voltage ride through. See Table 7.6.11.1-1 below for default voltage relay settings.

7.6.8 Frequency Relay Devices

Over and under frequency relays shall meet IEEE 1547 requirements including capability for under frequency ride through. The under-frequency trip setting shall not conflict with the under-frequency load shedding schemes on the Company's EPS. For adjustable under frequency settings, the chosen setting shall fall below the generator under frequency trip modeling curve of NERC PRC-006-2.¹⁷ See Table 7.6.11.1-1 below for default frequency relay settings.

7.6.9 Synchronizing Devices

The IC shall designate one or more synchronizing devices that employ a synchronizing protection element (25) such as motorized breakers, contactor/breaker combinations, or a fused contactor (if mutually agreeable) to be used to connect the DER facility's generator to the Company's EPS. This synchronizing device could be a device other than the interconnection interrupting device and shall be utility grade. The synchronizing device shall be capable of interrupting the current produced when the DER facility is connected out of phase with the Company's EPS. Synchronism check relay functions are required at all breakers through which the generation will be synchronized with the utility source. This includes any breakers where any part of the IC's DER facility will island and then synchronize back to the Company's EPS.

7.6.10 Overcurrent Relay Devices

Overcurrent protection is required to detect faults on the Company's EPS, as well as faults on the IC's system that cause overcurrent conditions on the Company's EPS. Overcurrent elements are required for both phase and ground in accordance with 7.6.3. Where a voltage-controlled phase (51C) element is required, relays shall utilize voltage sensing with Yg-Yg VTs specified in section 7.6.4.2.

7.6.11 Utility Grade Relay and Protective Device Settings and Verification

7.6.11.1 Default Voltage and Frequency Set points for all types of Energy Resources

¹⁷ See <https://www.nerc.com/pa/Stand/Reliability%20Standards/PRC-006-2.pdf>.

Unless otherwise specified by the Company, the default settings for voltage and frequency trip elements are required to have setting ranges according to the following table 7.6.11.1-1 and the final time delay settings shall be approved by the Company:

Table 7.6.11.1-1 Utility Grade Relay and Parallel Generation Default Voltage & Frequency Set points

DEVICE	PICKUP RANGE (Default set points in bold)	DEFAULT CLEARING TIME (sec)
Under Frequency 2 (81U)	\leq 56.5 Hz	0.16
Under Frequency 1 (81U)	\leq 58.5 Hz	300
Over Frequency 1 (81O)	\geq 61.2 Hz \leq f <62.0Hz	300
Over Frequency 2 (81O)	\geq 62 Hz	0.16
Under Voltage (27)	\leq 50% of Nominal	1.1
Under Voltage (27)	50% <V \leq 88% of Nominal	2
Over Voltage (59)	110% \leq V< 120% of Nominal	2
Over Voltage (59)	\geq 120% of Nominal	0.16

Settings other than the default, within the settings ranges in IEEE 1547, may be acceptable on a case-by-case basis and are subject to review and approval by the Company. DER facilities with Direct Transfer Trip installed may be required to have wider than the default settings to comply with ride through requirements. Note that consistent with IEEE 1547, the pickups are exact set points and the time delays are maximum total clearing times (including relay and device interruption time).

7.6.11.2 Synchronism Check Setting Requirements for all types of Generation

Unless otherwise specified by the Company, the default settings for utility-grade synchronism check elements are required to have settings according to the following table 7.6.11.2-1 and the final settings shall be approved by the Company:

Table 7.6.11.2-1 Relay Settings to Parallel with the Company EPS

Generator Size (kVA)	Max. Frequency Difference (Δf , Hz)	Max. Voltage Difference (ΔV , %)	Max. Phase Angle Difference ($\Delta \Phi$, degrees)
0-500	0.3	10	20
>500 – 1,500	0.2	5	15
>1,500 – 10,000	0.1	3	10

7.6.11.3 Company-designated Relays and Interconnection Customer Settings

1. The Company will review the IC's settings and the calibration and test results of those relays that the Company designates as being required to satisfy the Company's protection practices. In addition, the Company may require the relaying summary and logic diagrams depending on the complexity of the installation.
2. Any relay setting specified by the Company shall not be changed or modified at any time without the prior written consent of the Company.
3. The Customer shall be responsible to specify the settings, calibrate, test, and maintain the balance of their equipment.

7.6.11.4 Company Verification of Relay Testing

Prior to the Witness Test, the Company requires a letter from the IC stipulating that all Company–designated protective devices have:

- control wiring verified against the accepted design drawings, and
- the calibration test performed satisfactorily according to the relay setting document of the accepted design.

7.6.12 Unintentional Islanding Protection for DER

The Customer's DER system shall not energize a de-energized Company circuit; therefore, anti-islanding protection is required for parallel generation on the Company's distribution EPS. If the Company determines that an anti-islanding protection scheme is required to mitigate the risk of a formation of an island in addition to the generator facility's own islanding detection scheme then the Company will require direct transfer trip (DTT). The IC may propose alternative methods of anti-islanding protection of their own generation facility, although it is the IC's responsibility to demonstrate comprehensively the validity of such methods and the Company reserves the right to make the final determination as to which anti-islanding protection method is suitable to meet the EPS safety and reliability requirements.

Note: A Customer wishing to use a generation system as a stand-by or emergency generator shall submit details regarding an interlocking scheme or transfer switch to prevent the energization of a de-energized Company circuit that complies with National Grid ESB 750, Section 11.

7.6.12.1 General

1. The Company may reclose at any distribution EPS segment at any time without checking for de-energized segments as normal system operations to maintain service reliability. It is important to the DER operator to be aware of this possibility as it is the responsibility of the DER operator to trip off within 2 seconds in the event the EPS utility source is not present.
2. During DER impact evaluation, when a DER on the circuit causes the Company's system protection to be unable to trip for end of line faults, appropriate measures will be taken to correct this protection gap. The Company's device setting adjustments, additional protection devices, and/or customer impedance grounding may be required.
3. The requirements outlined below in regards to unintentional islanding mitigation risks are not applicable for DER proposed to be interconnected to a Company secondary network system. The Company's network systems are not designed for and cannot accept back feed.
4. Utility interactive inverters evaluated under these requirements shall not actively regulate frequency and/or voltage or provide Var support functions. Any inverter type generation established as frequency and/or voltage regulating or Var supportive will be reviewed under section 7.6.12.4 requirements.
5. DER threshold values shall be analyzed in aggregate where multiple DER projects are supplied from a single point of connection to the EPS. Individual DER projects on sub-divided or adjacent parcels may be evaluated based upon total aggregate nameplate ratings as an equivalent single point connection to the EPS.
6. For cases where the line section aggregated DER is $\leq 33\%$ of minimum load regardless of DER type mix and is connected to < 35 kV distribution EPS no additional requirements identified below shall be required.
7. For DER equipped with DTT, those DER facilities will not be factored into the 10 and 25% ratio screens identified in this bulletin.
8. Where used within this document, reclose blocking is a voltage supervised reclose permissive feature required at any mid-line automated interrupting device identified through the steps outlined. Where this feature is required, each mid-line device is also required to be SCADA equipped through the Company's distribution EMS cellular network.

9. A complete distribution feeder may contain multiple line sections. Depending on the aggregate DER size to load ratio, multiple line sections may require review and be screened accordingly per the steps outlined.
10. Each screen shall be repeated for each line section applicable to the proposed DER. Where DTT or reclose blocking is required based on the screens, it shall be applied at the sectionalizing device for that line section.

7.6.12.2 Islanding risk mitigation methods required

Special conditions outlined within this section are required at minimum, regardless of the screening outcomes applicable in the following sections.

1. Cases where the Company's PCC recloser is required regardless of DER type:
 - a. DER > 300 kW and DER > 33% minimum load and is connected to < 5 kV EPS.
 - b. DER connected to > 15 kV and < 35 kV EPS where DER > 50% onsite minimum host load.
2. Cases where additional EPS protection schemes, including but not limited to transfer tripping, may be required regardless of DER type:¹⁸
 - a. If line faults (phase and ground where applicable) cannot be cleared by DER protective device or the Company's PCC recloser.¹⁹
 - b. Unique arrangements not explicitly defined within this document at the Company's discretion.
 - c. If the DER cannot be tripped off with utility-owned devices when automated sectionalizing schemes will operate.
 - d. DER connected to > 35 kV EPS where DER > 50% onsite minimum load and the connecting line is radially supplied.
3. The Company shall be provided with access rights, whether easement or fee-owned right-of-way, of the Company's facilities on the IC's property for the PCC recloser installation serving their DER facility. See Figure 5 for a typical one-line configuration of a PCC recloser primary metered overhead service.

7.6.12.3 Certified DER²⁰

1. All inverters shall have an 88% voltage trip within two (2) seconds to be considered in this section.
2. Proposed DER rated ≤ 50 kW
 - a. No requirements.
3. Proposed DER rated > 50 kW and < 1000 kW
 - a. Line section aggregated non-certified DER is ≤ 10% of mix.
 - i. No additional requirements.
 - b. Line section aggregated non-certified DER is > 10% and ≤ 25% of aggregate DER.
 - i. Sandia screening²¹ may be applicable depending on inverter models on segment.

¹⁸ While the intent of this unintentional islanding protection policy is to encourage DER installations while minimizing inhibitive impacts to the DER installation, the Company reserves the right and flexibility to enforce protective measures deemed required for the safety and reliability of the EPS.

¹⁹ Customers should be aware that >15kV class circuits typically involve more complex protection schemes, which can be more likely to require DTT due to inability to see and trip faults in an acceptable time frame, in addition to operational issues that may be present at these voltage classes (23kV and 34.5kV).

²⁰ Inverter firmware derating is not acceptable for reduction of system size to satisfy thresholds within this section.

²¹ Sandia screens (<http://energy.sandia.gov/wp-content/gallery/uploads/SAND2012-1365-v2.pdf>) are valid only for certified inverters that have been confirmed, in writing from the manufacturer, to meet the definition of the Sandia Frequency Shift (SFS), or Sandia Voltage Shift (SVS) as positive feedback based methods or for inverters using impedance detection with positive feedback. SFS and SVS both rely on positive feedback to work.

- ii. Company-owned PCC recloser and reclose blocking required on line segment sectionalizing device if Sandia screens not passed.
 - 1. Detailed risk of islanding (ROI) study may be performed at the IC's request. If results of the detailed study show no significant risk of islanding for a period greater than 2 seconds, then the recloser and reclose blocking is waived.
- c. Line section aggregated non-certified DER is > 25% of all DER.
 - i. Company-owned PCC recloser
 - ii. Reclose blocking required on line segment sectionalizing device²²
 - 1. Detailed ROI study may be performed at the IC's request. If results of the detailed study show no significant risk of islanding for a period greater than 2 seconds, then reclose blocking is waived. Company-owned PCC recloser is waived for aggregate DER ≤ 67% of line load to generation ratio or < 500 kW.
- 4. Proposed DER rated DER ≥ 1000 kW
 - a. Company-owned PCC Recloser required.
 - b. Reclose blocking required on line segment sectionalizing device if line segment aggregate DER > 50% of minimum load.

7.6.12.4 Non-certified & voltage or frequency regulating inverters, induction & synchronous machines

- 1. Require ANSI C37.90 protective relay with IEEE 1547 voltage and frequency tripping and restoration functions.
- 2. Total aggregate line section DER > 33% minimum load
 - a. DTT required.

7.7 Monitoring and Control (M&C) at DER Facility

DER ranging from 500 kW and above shall require (300 kW and above for projects connected to primary circuit voltages less than 5 kV) supervisory control and data acquisition (SCADA) communication for visibility to the Company's energy or distribution management systems (EMS or DMS) and to incorporate the ability for the Company's system operators from regional control centers via EMS to remote trip the generation, or DER facility, from the Company's EPS. This visibility is essential in maintaining daily system operability and the flexibility to transfer loads and feeder segments to allow for system upgrades, repairs, seasonal loading transfers, and other normal distribution system management functions that may require a SCADA remote terminal unit (RTU) or a PCC Recloser at a DER facility.

Table 7.7-1 Monitoring and Control Requirements by Size for DER (1)

	Less than 50 kW	Individual or Aggregated 50 kW and less than 500 kW (3)	Individual or Aggregated 300 kW and Greater on 5 kV and less EPS (3)	Individual or Aggregated 500 kW and Greater
Monitoring	Monitoring <i>may</i> be required	Monitoring <i>may</i> be required	Monitoring <i>shall</i> be required	Monitoring <i>shall</i> be required
Control (PCC Recloser)				PCC Recloser <i>shall</i> be required (2)
Control (RTU)		Basic control <i>may</i> be required	Control <i>shall</i> be required	

Notes:

Positive feedback – detecting a deviation in grid parameters and acting to try to make that deviation from nominal worse. Where acting to try to make that deviation worse, the perturbations must push harder as the deviations from nominal increase. The algorithm must be able to push bi-directionally in order to be considered for this screen.

²² Where feasible, installing a PCC recloser in front of the non-certified DER may reduce or eliminate any further requirements to the subject applicant DER.

- (1) *EMS-RTU installations may be required for DER applications not covered by the conditions in this table as determined by the Company on a case-by-case basis. Some examples are situations where an RTU may be required could occur where there is EPS feeder selectivity operation or significant current on a line section for switching procedures, paired DER or DER and facility load at a PCC, and if the proposed DER system is subject to NYISO requirements.*
- (2) *Where a PCC recloser is required or requested and approved, the EMS-RTU requirement is waived, since SCADA requirements will be extracted from the Company's PCC recloser for EMS purposes unless cellular communication cannot be established at the PCC recloser location.*
- (3) *Basic control and monitoring requirements for DER in the 50 kW up to 500 kW range will be determined by the Company based on the following parameters:*
 - **Company Distribution System Voltage** – *Control may be required for lower proposed system sizes interconnecting at the Company's 5 kV voltage classes and below.*
 - **Hosting Capacity** – *Control and monitoring may be required as a means to increase solar PV DER hosting capacity.*
 - **Anti-Islanding Requirements** – *Pursuant to Section 7.6.12 Unintentional Islanding Protection for DER requirements herein, a PCC recloser may be required for monitoring and control.*
 - **NY SIR Screen Borderline Violations** – *Systems that only marginally pass or fail a given screen will require monitoring if it is not already a requirement, and may also require control.*
 - **NYISO Requirements** – *If the proposed system is subject to NYISO requirements, monitoring and/or control will be required if it is not already a requirement.*
 - **Distribution Automation** – *Potential monitoring and control screens must consider the aggregate line section generation in multiple circuit configurations. The need for control due to the proposed system's impact on neighboring line sections is an increasing concern as Distribution Automation continues to be implemented in the Company's service area to ensure customer reliability and efficiency is not sacrificed. The Company may require control if the existing DG exceeds an aggregate capacity greater than the minimum load according to Section 7.6.12 herein on any of the neighboring line sections.*
 - **Loading** – *Control and monitoring may be required as output exceeding the local loading raises a number of concerns across voltage, thermal, and protection power system criteria.*
 - **Phase Balancing** – *Control and monitoring may be required as aggregate generation on single phase line sections may create adverse impacts to the Company's distribution system planning and operations.*

1. Company RTU input requirements.

The minimum set of required data values at the PCC for solar PV DER in the individual or aggregated 50 kW and less than 500 kW range for basic monitoring shall include:

- Per phase voltage and current,
- Three phase values for real (watts) and reactive (VARs) power, and
- Power factor.

For DERs as determined in Table 7.7-1, the required inputs from the RTU to the Company's EMS for status and control of DER systems connected to the Company's EPS shall be as follows:

- Status of individual generator breaker(s)
- Status of main or interconnect breaker at the PCC
- Control input for the "designated generator interrupting device"

- Three phase line current for each generator
- Three phase line current at the PCC with the Company
- Three phase line-to-line voltage for each generator
- Three phase line-to-line voltage at the PCC with the Company
- Output kW for each unit (+ delivered to the Company, - received)
- Output kVAR for each unit (+ delivered to the Company, - received)
- Total MW (+ delivered, - received) at the PCC
- Total MVAR (+ delivered, - received) at the PCC

Notes:

- (1) The Company will provide an RTU point list for inputs required at the DER system.*
- (2) Exceptions to the list above may be considered by the Company on a case-by-case basis.*
- (3) The control portion would only involve the remote trip of the IC's interrupting device(s) designated by the Company or the Company's PCC recloser where installed. When a remote RTU trip command is issued, the local DER facility's interrupting device must be designed for reset through a manual process and is subject to review by the Company for acceptance.*

- 2. Company RTU installation requirements.** When a Company RTU is specified for a parallel generation project, the Company will determine the requirements for equipment, installation, and communications media in the interconnection study for the DER system. The IC will be responsible for all initial and recurring costs associated with communications for this RTU. General requirements for the RTU installation in the IC facility are, but not limited to:
 1. The RTU cabinet is typically 42" H x 30" W x 26" D and shall be wall, pole or strut mounted with the bottom edge 36" above the floor. A 5-foot clear working space shall be maintained in front of the mounting panel.
 2. A dedicated 20A, 120VAC, single phase 60 hertz power circuit is required for the RTU cabinet. All conduit and wiring (minimum of No. 10 AWG copper) to the telemetry cabinet for this circuit shall enter the cabinet from the bottom. A three (3) foot length of all conductors shall be provided for final Company connection.
 3. The IC will be responsible for mounting this equipment in their installation, subject to Company approval. The IC will provide space, power, and all input connections for this package.
 4. The following guidelines shall be adhered to:
 - 1) The RTU shall be remote from heavy traffic areas, work areas and loading areas.
 - 2) The RTU shall be remote from heat producing or high electrostatic or electromagnetic field producing equipment.
 - 3) The analog inputs to the RTU shall be provided by DNP3 protocol communication. Where DNP3 communication is unavailable, the analog inputs shall be +1.0mA DC at rated input, +2ma DC maximum; see Section 7.7.1 above.
 5. For telecommunication provider steps and requirements:
 - 1) The local serving telephone company's facilities demarcation and equipment shall be located as close to the RTU cabinet and protection relays, as feasible, relative to the IC's mutually agreed upon location.
 - 2) The IC is responsible for arranging the installation and paying all costs associated with required telecommunication line(s) including maintenance and recurring telephone company charges.
 - 3) The IC shall be responsible for all telephone company coordination, installation, final connections, and commissioning of all required telecommunication circuits.
 - 4) The IC is responsible to complete telephone company's form requirements such as high voltage protection (HVP) form when arranging for the telecommunication

service. The technical information normally provided includes, but not limited to: total square footage area of Ground Grid/Mat, Grid Impedance (in Ohms) to Remote Earth, total expected Fault Current (line-to-ground) in Amps RMS (or Amps Peak), Earth Return Current (as % of Total Fault Current), X/R Ratio, and Soil Resistivity (layer depth information in feet).

- 5) The IC is responsible to comply and coordinate with their telephone company's commissioning process of telecommunications circuits required with the Company.

7.8 Voltage and Frequency Ride Through and Control Requirements

7.8.1 Voltage and Frequency Ride Through

DER shall meet the requirements of IEEE 1547.

7.8.2 Voltage and Frequency Control

1. All DER shall meet the requirements of IEEE 1547. Field adjustable settings shall not be changed without express written consent of the Company.
2. The voltage and frequency capabilities permitted in IEEE1547 shall be disabled by default in accordance with Table 7.8.2.2-1 unless otherwise approved by the Company.

Table 7.8.2.2-1: Default Mode Settings for Inverter-based Utility Interactive DER

Function	Default Activation State
SPF, Specified Power Factor	OFF ²³
Q(V), Volt-Var Function with Watt or Var Priority	OFF
SS, Soft-Start Ramp Rate	ON Default value: 2% of maximum current output per second
FW, Freq-Watt Function OFF	OFF

If a device does not have the above mode settings, the device shall operate in unity power factor mode with any available grid support functions disabled.

7.8.3 Return to Service

The DER shall not connect or return to service following a trip (including any ground fault current sources) until detecting 5 minutes of healthy utility voltage and frequency. Detection and return to service function shall be performed by utility grade relay where utility grade relay is required. "Healthy Utility Voltage and Frequency" is defined by Table 7.8.3-1, in accordance with the Enter Service Criteria in IEEE Std. 1547-2018 section 4.10:

Table 7.8.3-1: Return to Service Parameters for DER

Utility Voltage Parameter	Default Value
Minimum Return to Service Voltage:	0.95 per unit of nominal voltage
Maximum Return to Service Voltage:	1.05 per unit of nominal voltage
Minimum Return to Service Frequency:	59.5 Hz
Maximum Return to Service Frequency:	60.5 Hz

²³ OFF and operating at unity PF. Or set to ON with unity PF.

8.0 Testing and Commissioning

1. The Company reserves the right to witness the IC's functional testing of the required devices, i.e., trip tests.
2. All Company-designated relay functions and all synchronizing elements will be witness-tested/verified by the Company's personnel prior to energization.
3. A letter, written by the Customer or their assigned agent, indicating the protection and control scheme has been functionally tested in accordance with the Customer's submitted design as accepted by the Company, shall be completed prior to the Company's witness testing.
4. The IC shall submit a testing and commissioning plan (TCP) to the Company for review at least twenty (20) business days prior to the scheduled witness test. If needed, consult the Company for guidance on preparing a TCP. This activity will normally be performed as specified in the NY SIR.
5. All required equipment test reports shall be submitted per ESB 751 prior to final TCP acceptance.
6. The TCP shall be finalized as accepted by the Company no later than five business (5) days prior to functional testing of the Company-designated protective devices.

9.0 Operating

1. The customer's DER system shall maintain a power factor at the PCC in accordance with the NY SIR; at or between 0.90 leading or lagging (Var or voltage support can also be considered within machine ratings) unless more strict requirements apply in the Company's CESIR. Corrective equipment may be required and, if so, it will be at the IC's expense; refer to ESB 750. It is the Company's expectation that the IC will strive to maintain a power factor at their service point that does not adversely affect the power quality (PQ) of the Company's EPS; see ESB 750.
2. The Company requires a Sequence of Operations (SOO) from the Customer. The Company also requires an operating description from the Interconnection Customer for normal, alternate, and emergency (if proposed) operations, if the Customer desires to operate in these modes and in the event of any changes to the existing procedures.
3. The IC is responsible for the operation and maintenance of their facilities up to the demarcation point of the IC's service on the Customer's property in accordance with the Company's ESBs.
4. The IC shall follow the Company's specified switching protocol upon commissioning, synchronizing, and return-to-service situations with the Company's distribution system operator; see ESB 755 for more information on IC operating and maintenance responsibilities.
5. Should the IC's DER facility experience unexpected tripping of their interrupting device, the IC shall first perform their own extensive analysis of all possible causes for trips of their own system before attempting to resolve those issues through the Company.
 6. Where the Company is requested to supply demand pulse information (either analog or digital), its use is not intended for generator dispatch or control.
 7. Should the Customer Facility experience unexpected tripping of their interrupting device, the Customer shall first perform their own extensive analysis of all possible causes for trips of their own system before attempting to resolve those issues through the Company

10.0 Power Quality Monitoring

10.1 Power Quality Compliance Verification

If during the study the interconnection of a DER system is identified as having the potential to cause PQ effects on the Company's EPS, then PQ monitoring shall be installed by the Company or Company-accepted third party PQ testing company to verify the Customer is maintaining its PQ with and without generation. Third party PQ test methods and results may be submitted to the Company for review and acceptance. These verification tests shall include, at a minimum, the following in accordance with the Company's [Electricity Tariff](#) and the limits and cost responsibilities specified in the NY SIR:

- Check service point voltage for any discernible voltage fluctuation.
- Check service point frequency for any discernible frequency fluctuation.
- Check PCC power factor to ensure it is no less than 90% (leading or lagging).
- Check service point harmonic distortion to ensure limits specified in ESB 750 and the NY SIR as applicable, are maintained. Current harmonic distortion shall not adversely affect voltage harmonic distortion, the Company's EPS, or service to other customers.

10.2 Power Quality Disturbance and Mitigation

1. If disturbances on the Company's Distribution EPS and/or to other customers are suspected to originate from a customer with an installed DER system, PQ monitoring shall be installed to verify the Customer is maintaining their power quality in accordance with the Company's ESB 750 and the NY SIR.
2. If it is determined that system modifications or changes are needed in order to mitigate the disturbance issue, the cost of such modifications or changes shall be borne by the Interconnection Customer.
3. If any power quality concerns as a result of the customers DER installation cannot be immediately corrected, the IC **will not be permitted** to continue generation until such concerns are resolved to the Company's satisfaction.

10.3 Transient Overvoltage/Load Rejection Overvoltage (LROV)

The DER facility shall limit its cumulative instantaneous overvoltage according to Figure 3 of IEEE Std. 1547-2018 section 7.4.2.

Most inverters have a 'self-protective overvoltage' setting in the inverters that, if enabled, is capable of tripping for no higher than 1.4pu voltage in 1ms or less clearing time. This set point is one acceptable means to meet the requirements if a letter from the inverter manufacturer is provided to the Company stating that this setting (or tighter) is enabled in the inverters to be installed on the site, and the inverter voltage response adheres to the curve in IEEE 1547. The Customer shall provide a letter from the inverter manufacturer or a National Recognized Testing Laboratory (NRTL) confirming the requirements from the standard are met. The letter shall be on the manufacturer or NRTL's letterhead and include the firmware version and serial numbers of each inverter for the installation. Test data and/or standards certification supporting these statements may also be required at the discretion of the Company.

11.0 Facility Audit

The Company shall reserve the right to periodically audit the IC's generation equipment installation and service connection for compliance with the Company's requirements.

12.0 Disconnection by the Company (Isolation)

The Company reserves the right to have the IC remove their DER system from the Company's EPS at any time upon the Company's request. Normally, such requests result from the need to

facilitate maintenance, testing, or repair of Company facilities. The Customer's generator disconnect switch²⁴ may be opened by the Company (isolating the Customer's generating equipment), without prior notice to the IC, for any of the following reasons:

- System emergency operations require such action.
- Company periodic checks of IC's interfacing equipment reveal a hazardous condition, or lack of necessary maintenance for equipment necessary to protect the Company's EPS.
- Generating equipment interferes with other customers or with the operation of the Company's EPS.
- When required protective relaying and/or tele-protection is altered, inoperable, or missing.
- When required special equipment necessary for operating control (e.g., telemetering/SCADA) on the Company's EPS is inoperable or missing.
- Parallel operation, other than for NY SIR testing of type tested inverters, prior to Company approval to interconnect.
- Failure to make available records of verification tests and maintenance of the IC's protective devices designated by the Company, unless otherwise specified in the NY SIR.
- Situations where the area EPS is in a non-normal operating scenario and the generator has not been studied for interconnection in that specific operating scenario.

13.0 REVISION HISTORY

<u>Version</u>	<u>Date</u>	<u>Description of Revision</u>
1.0	06/01/07	Initial version of new document superseding all previous revisions of ESB 756.
2.0	09/06/11	Revise for Dec. 2010 NY SIR.
3.0	09/22/14	Revise for Apr. 2013 & Feb. 2014 NY SIR and technical updates in Sections 4, 5, and 6.
4.0	08/03/17	June 2017 revise for Apr. & Nov. 2016 and Feb. 2017 NY SIR and changes in National Grid protection practices.
4.1	12/18/17	October-December 2017 interim amendments to Sections 7.6.11, 7.7, and 7.8.
4.2	02/09/18	January-February 2018 interim amendments to Sections 7.6.11, 7.6.12, and 7.8.
5.0	06/29/18	June 2018 revised for April 2018 NY SIR, IEEE 1547-2018, and updated National Grid practices.
6.0	12/04/19	December 2019 revised for updated National Grid practices.

EXHIBITS ATTACHED

²⁴ Refer to Section 7.4 regarding technical requirements for draw-out breakers over 600 V and the Company's [Electricity Tariff](#) for limitations of service.

EXHIBIT 1: Company Requirements for DER Systems Not Eligible for the Expedited Process

These are Company items to be considered in the Interconnection Customer's DER System Project Schedule.

ID	Activity Description	NY SIR §I.C / ESB ref.
Project Definition & Conceptual Analysis Phase		
1	IC Form K w/technical submittal & prelim. design received	Steps 1 - 3
2	Company Preliminary Technical Assessment & cost estimate for CESIR	Step 4
3	Company Form K Interconnection Agreement and Form G as needed are executed with IC	Step 5
4	IC commits to final CESIR and provides advance payment	Step 5
Preliminary Design Review Phase		
ESB 751 Stage A		
5	IC's preliminary project schedule, design, specifications, test reports, and protective device settings received.	Step 6
6	Company final CESIR and Interconnection Service Plan with Planning Grade construction estimate	Step 6
7	Company reviews IC preliminary design & returns comments	Step 6
Final Design Review Phase		
ESB 751 Stage B		
8	IC commits to utility system modifications in CESIR & Interconnection Service Plan and provides advance payment	Step 7
9	IC's project schedule, final design, specifications, & protective device coordination analysis received	Step 7; ESB 750 & 752 or 753 or 754 or 758
10	Company reviews IC's design & returns comments	Step 8; ESB 752 or 753 or 754 or 758
Installation Progress Review Phase		
ESB 751 Stage C		
11	IC's corrected design, test reports, & protective device settings received	Step 8; ESB 752 or 753 or 754 or 758
12	Company reviews IC's design & returns comments	Step 8; ESB 752 or 753 or 754 or 758
Installation Compliance Verification Phase		
ESB 751 Stage D		
13	IC's advance notice of functional testing received	Step 9; ESB 755
14	Electrical inspection certification approval received from municipal or AHJ authorized 3 rd party agency	ESB 750 & 752 or 753 or 754 or 758; Local AHJ
15	IC's acknowledgement of satisfactory wiring & relay calibration tests received	Steps 9 & 10; ESB 755
16	Company witness of IC's functional testing	Step 10; ESB 755
17	Company field audit of IC's service connection	Steps 8 - 10; ESB 750 & 752 or 753 or 754 or 758
18	IC resolves open compliance verification items	Steps 8 - 10; ESB 750 & 752 or 753 or 754 or 758
19	Verification testing satisfied	Steps 9 & 10
Energization & Synchronization Phase		
ESB 751 Stage E		
20	Company's metering installation complete	Steps 8 - 10; ESB 750 & 752 or 753 or 754 or 758
21	IC's energization sequence plan received for interconnections > 600 V	Steps 9 & 10; ESB 755
22	Company's supply system interconnection complete	Steps 9 & 10
23	Company review/acceptance of IC's resolved open items in 18 above.	Steps 9 & 10
24	Company proceeds with energization	Steps 9 & 10
25	IC is permitted to synchronize generation facility in parallel to the Company's supply	Step 10
Project Closeout Phase		
ESB 751 Stage F		
26	For interconnections > 600 V, remainder of IC's protective system functional testing documented in an acknowledgement letter submitted to the Company within 10 business days after energization	Step 11; ESB 755
27	IC's as-built design drawings received within 90 days for interconnections > 600 V	Step 11; ESB 750 § 1.7
28	Company reconciliation of project costs with IC within 90 days of as-built documents received.	Step 11

EXHIBIT 2: Reference Maps of National Grid upstate NY Secondary Network EPS Areas

NY Central Division

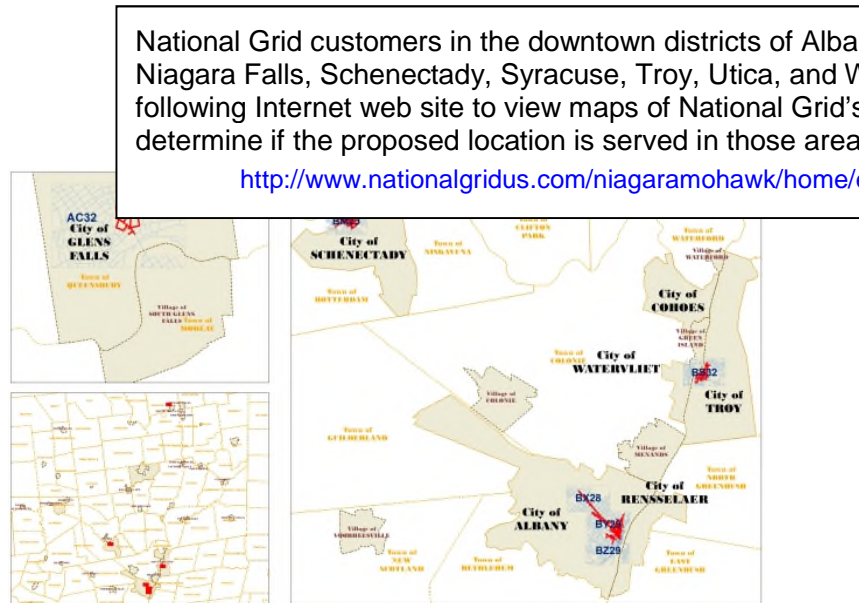
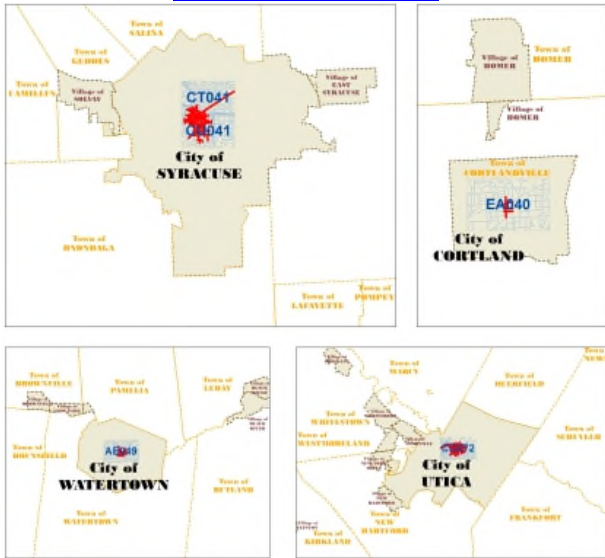

National Grid customers in the downtown districts of Albany, Niagara Falls, Schenectady, Syracuse, Troy, Utica, and Watertown should visit the following Internet web site to view maps of National Grid's secondary network and determine if the proposed location is served in those areas:

<http://www.nationalgridus.com/niagamohawk/home/>

NY Western Division

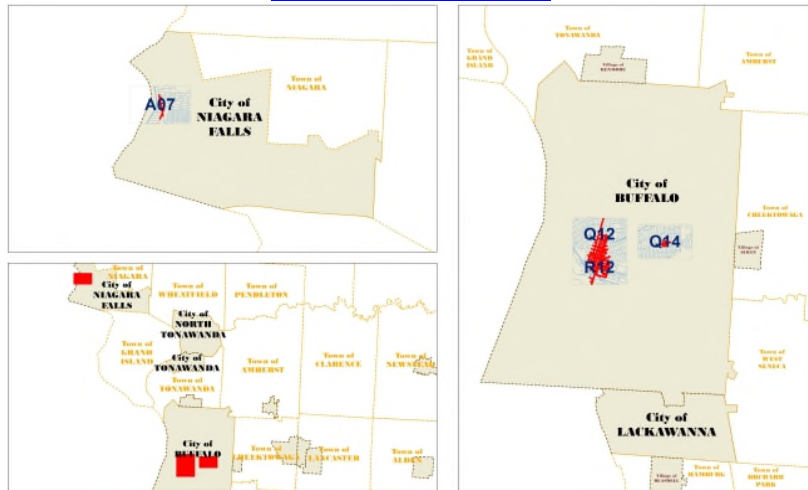

EXHIBIT 3: Distribution Secondary Grid and Spot Network Description

In Upstate New York, National Grid generally has two types of electrical distribution systems: radial and distribution secondary network systems. While the vast majority of customers are served from radial power systems, some customers in the downtown districts of Albany, Buffalo, Cortland, Glens Falls, Niagara Falls, Schenectady, Syracuse, Troy, Utica, and Watertown are served by distribution secondary network systems; see Exhibit 3 for area maps. These systems are designed to meet the higher reliability needs, dense load levels, and limited space commonly encountered in urban areas.

A distribution secondary network system delivers electricity through a complex and integrated system of transformers and underground cables that are connected and operate in parallel. Power can flow in either direction on the secondary service delivery lines, commonly called secondary distribution lines. The loss of a single line or transformer in a secondary network system does not cause an interruption of power, unlike radial systems where there is only one line and one path for power to flow from the distribution substation to the customer's point of service. If a radial system experiences an outage, service is interrupted to the customers until repairs are completed; this is less likely to be the case in a distribution secondary network system.

In distribution secondary network systems, devices called "network protectors" are usually arranged to automatically connect its associated transformer to the network system when conditions are such that the transformer when connected will supply power to the network and to automatically disconnect the transformer from the network when power flows from the network to the transformer. The integration of DER into a distribution secondary network system may result in network protectors exceeding their original design criteria or nameplate ratings.

Example Distribution Secondary Grid Network Diagram

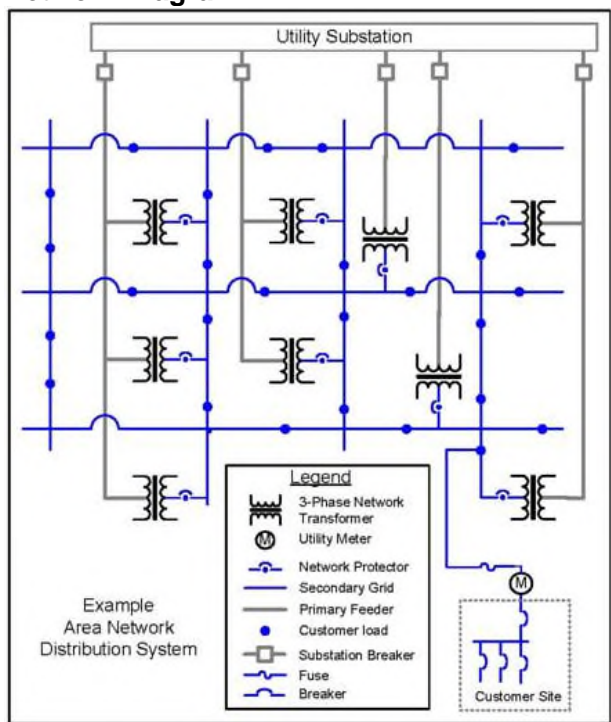

Underground secondary grid (area) network systems deliver power to each customer through a complex and integrated system of multiple transformers and underground cables that are connected and operate in parallel.

Example Distribution Secondary Spot Network Diagram

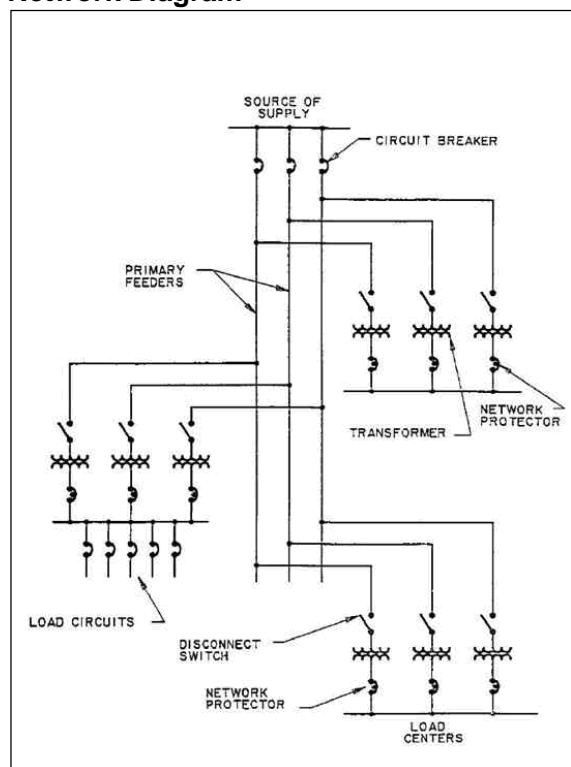

Spot networks are similar to grid (area) networks except they serve a single premise.

EXHIBIT 4: Recommended Guidelines for Residential and Commercial Single-line Diagram Submittals

Refer to **Figures 1** and **2** for typical illustration and symbology.

1. Identify the project, Company's electric service order (ESO) number, location and submitter's name and address.
2. Indicate standard and any non-standard system voltages, number of phases, and frequency of the incoming circuit. Indicate wye and delta systems; show whether grounded or ungrounded.
3. Identify cable, conductors and conduit, the type and number. The Company is interested in how the power is getting from the service point to the protective equipment.
4. Identify wiring troughs and/or junction boxes where used.
5. Use standard symbols. See NFPA 70B or IEEE Standard 141 for symbols in typical electrical single-line diagram development.
6. Identify the service equipment's switch and fuse or circuit breaker as to manufacturer, type, rating, catalog number, etc. Service equipment must be able to safely interrupt the maximum available fault current from the supply; refer to NEC Articles 110 and 230.
7. Show billing meter trough or instrument transformers' cabinet (C.T. cabinet) in circuitry. Indicate source and load for the circuit. Refer to Section 7 in the Company's [ESB 750](#) for acceptable metering configurations.
8. Identify other protective devices and ratings. Include ratings in volts and amps, the interruption rating, and type and number of trip coils on circuit breakers. Also, note any special features of fuses (current limiting, dual element, etc.).
9. Identify ratios of current and potential transformers, taps to be used on multi-ratio transformers, and connection of dual ratio current transformers if used.
10. Identify any relays, if used, and their functions. Indicate which interrupting device(s) are tripped by the relay(s) used.
11. Show connections, winding configuration, and ratings of power transformers for any to be used. Show the transformer impedance and X/R ratio.
12. Indicate the connections, winding configuration and ratings of grounding transformers if any are to be used. Show the impedance and X/R ratio.
13. Identify Generator Disconnect and its ratings, the service point, and the PCC.
14. Provide catalog cut-sheets clearly identifying exact model to be installed for devices and equipment of mutual interest to the Company and of the IC. Equipment shall be inclusive but not limited to the main service arrangement, any transformer in the circuit path between the point of common coupling and the generator, the generator interrupting device, the utility disconnect, and inverter(s) and/or relay(s).

FIGURE 1: Sample Distributed Generator One-Line Diagram

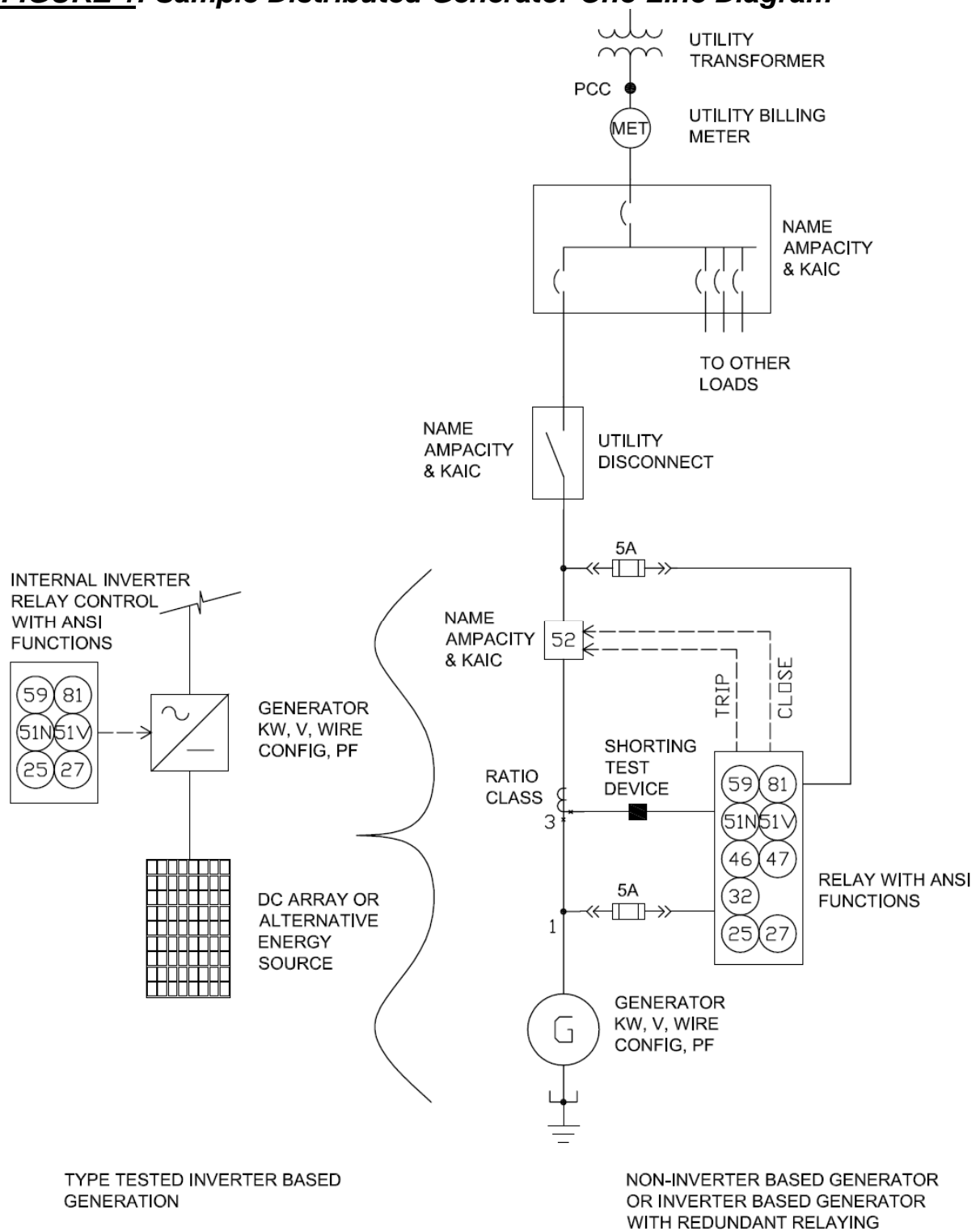

[TYPICAL ONLY]

FIGURE 2: Typical Symbolology for Electrical Drawings

ELEMENTARY SWITCH DEVICES								CONTACTS AND RELAYS	
FLOW		PRESSURE		LIQUID LEVEL		TEMPERATURE		CONTACTS	
CLOSED RISING	OPENS RISING	CLOSED RISING	OPENS RISING	CLOSED RISING	OPENS RISING	CLOSED RISING	OPENS RISING	NORMALLY OPEN OR "a" CONTACT	NORMALLY CLOSED OR "b" CONTACT
LIMIT				PUSHBUTTON		RELAY COIL			
NORMALLY OPEN	NORMALLY OPEN - HELD CLOSED	NORMALLY CLOSED	NORMALLY CLOSED - HELD OPEN	NORMALLY OPEN	NORMALLY CLOSED				
ELEMENTARY FUSE DEVICES			BATTERY OR DC SOURCE			CONNECTIONS			
FUSE	SOLID LINK	IN REMOVABLE CARTRIDGE OR PULL BLOCK	GENERAL OR SINGLE CELL	MULTI CELL (COMMON)	GROUND	SHORT CIRCUIT (3-PHASE CONNECTION)	SEPARABLE CONNECTORS OR DRAW OUT FEATURE		
DISCONNECTS (UNDER 600 V)		CIRCUIT BREAKERS			TRANSFER SWITCH				
NON-FUSED DISCONNECT	FUSED DISCONNECT	GENERIC OR AIR TYPE	CB OR INTERRUPTING DEVICE (OTHER THAN AIR)			TWO POSITION	THREE POSITION		
CAPACITOR	ANTENNA	THERMAL OVERLOAD	INDICATING LIGHT * = LENS COLOR:						
			A - AMBER B - BLUE C - CLEAR G - GREEN O - ORANGE P - PURPLE R - RED W - WHITE Y - YELLOW						
TRANSFORMERS AND INSTRUMENT TRANSFORMERS									
3-PHASE, WYE			3-PHASE, DELTA				3-PHASE ZIGZAG		
GROUNDING NEUTRAL	UNGROUNDING	DELTA	CORNER GROUNDED	OPEN DELTA	OPEN DELTA CORNER GROUNDED	BROKEN DELTA	UNGROUNDING	GROUNDING	
GENERIC TWO WINDING TRANSFORMER	GENERIC THREE WINDING TRANSFORMER, TERTIARY TYPE		CURRENT TRANS. WITH POLARITY MARKS SHOWN		FUSED POTENTIAL TRANSFORMER				
			EXTERNAL TO BUSHING		BUSHING MOUNTED				
			■ OR ● OR ×						

EXHIBIT 5: Recommended Guidelines for Functional Single-line Diagram Submittals

Refer to **Figures 3** and **4** for typical illustrations.

In addition to **Exhibit 4**:

15. On functional single-line diagram submittals, industry standard device numbers are necessary. Refer to the following List of Standard Device Numbers (See latest edition of **ANSI C 37.2**):

<u>Device Number</u>	<u>Function</u>
25	Synchronizing Device / Synchronism Check
27	Under Voltage Relay
32	Directional Power Relay
46	Negative Sequence Voltage
50	Instantaneous Overcurrent Relay
51	Phase Overcurrent Relay
51C	Voltage Controlled Overcurrent Relay
51G	Ground Overcurrent Relay
51N	Neutral Overcurrent Relay
51V	Overcurrent Relay, voltage restraint
52	Breaker
52R	Recloser
59	Over Voltage Relay
59G	Neutral Voltage Relay
59N	Zero Sequence Voltage Relay
62	Time-delay Stopping or Opening Relay
64	Ground Protective Relay
79	AC Reclosing Relay
81	Over and Under Frequency Relay
86	Locking - Out Relay
87	Differential Relay

FIGURE 3: Sample Functional Single-Line Diagram

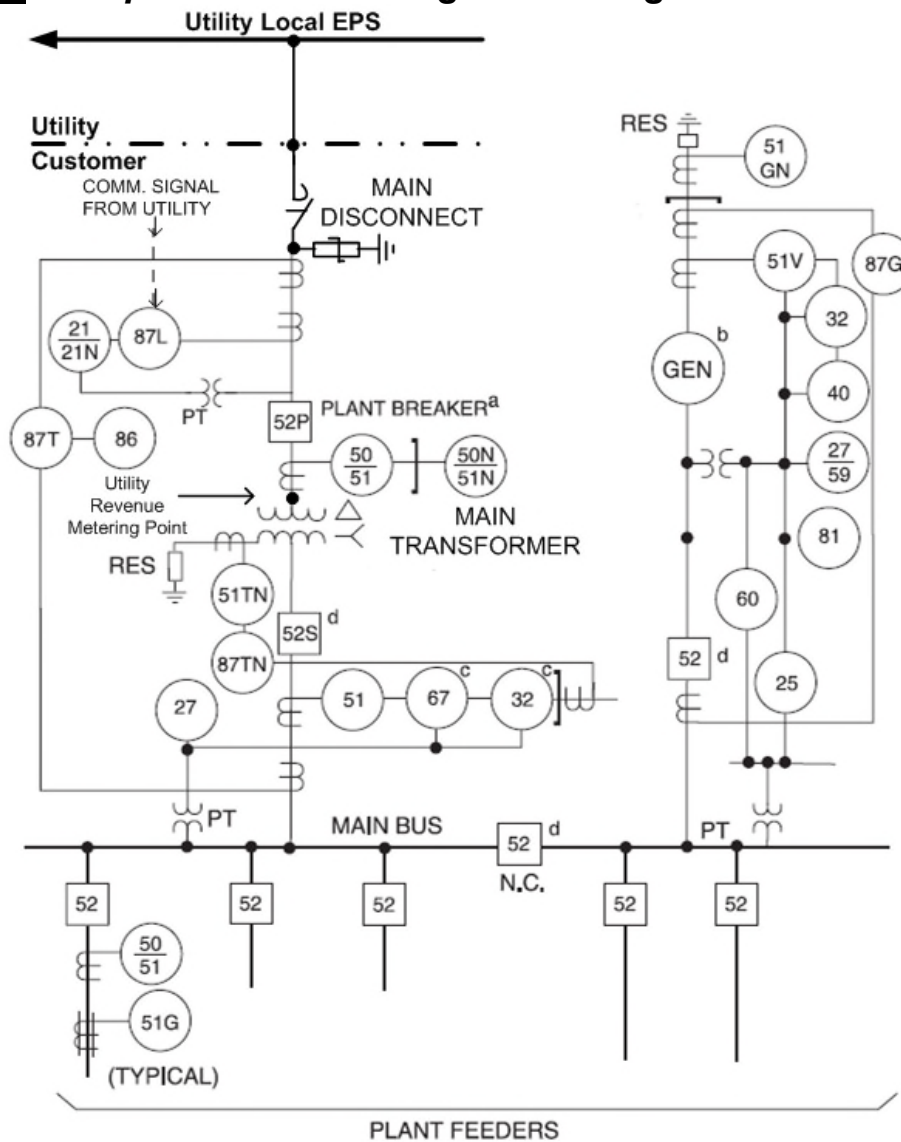

- NOTES:
- a. A fused interrupter switch may also be used instead of the breaker.
If fused interrupter is used, relaying associated with the transformer is not used.
 - b. In-plant generator for partial plant load and back-up.
 - c. Devices 67 and 32 are directional. Polarity of CTs and PTs must be verified.
 - d. Overcurrent and bus differential protection should be provided for the main, generator, and tie breakers, but protection is not shown here. See IEEE Std. C37.95 and C37.97.
- Trip function lines not shown.
See IEEE Std. 242 Buff Book "Recommended Practice for Protection and Coordination of Industrial and Commercial Power Systems" for more information.

[TYPICAL ONLY]

FIGURE 4: Typical $3V_0$ Requirements for Local EPS Ground Fault Detection

The Company requires ground fault protection on any system that can be a generation source to protect any equipment that can be parallel supplied from two sources. In the cases where the primary winding of the transformer supplying the facility is delta, a “zero-sequence” voltage or “ $3V_0$ ” scheme is required. Typically, this is implemented by installing potential transformers (PTs) on the primary system as a source to a voltage sensing relay containing a ground overvoltage device function (59N or 59G) capable of detecting the presence of a single line-to-ground fault on the Local EPS.

Notes:

1. The Company may waive this requirement depending on the restrictions of the local EPS.
2. Trip signal is shown to remove generator from Company’s EPS at the generator interrupting device. Alternatives may be proposed for Company approval for alternative arrangements.
3. Yg-Broken Delta arrangement is typical of an electromechanical relay installation while Yg-Yg is commonly applied for a microprocessor relay installation.

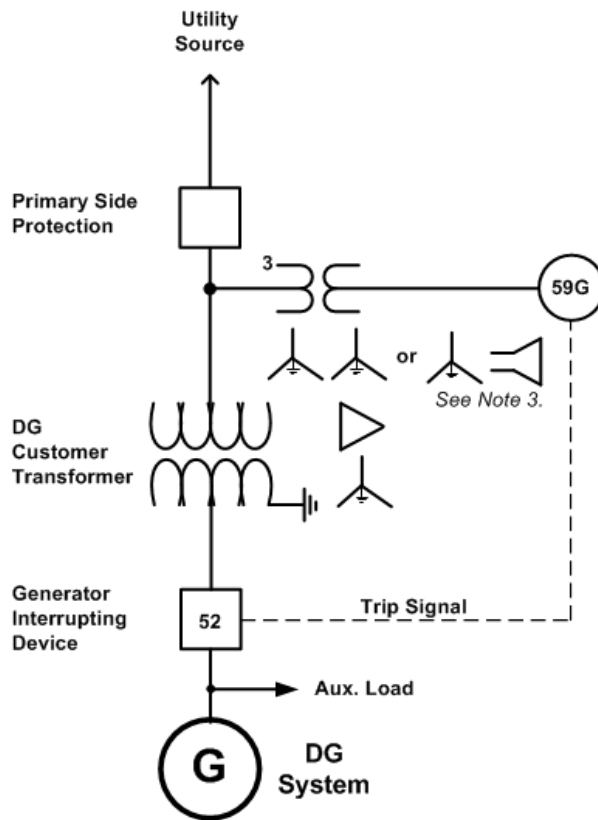

-- INFORMATION ONLY --
 -- SIMPLIFIED DIAGRAM NOT ALL DETAILS SHOWN --

FIGURE 5: Typical Overhead Single Primary Service Configuration in NY for Large DER Installations

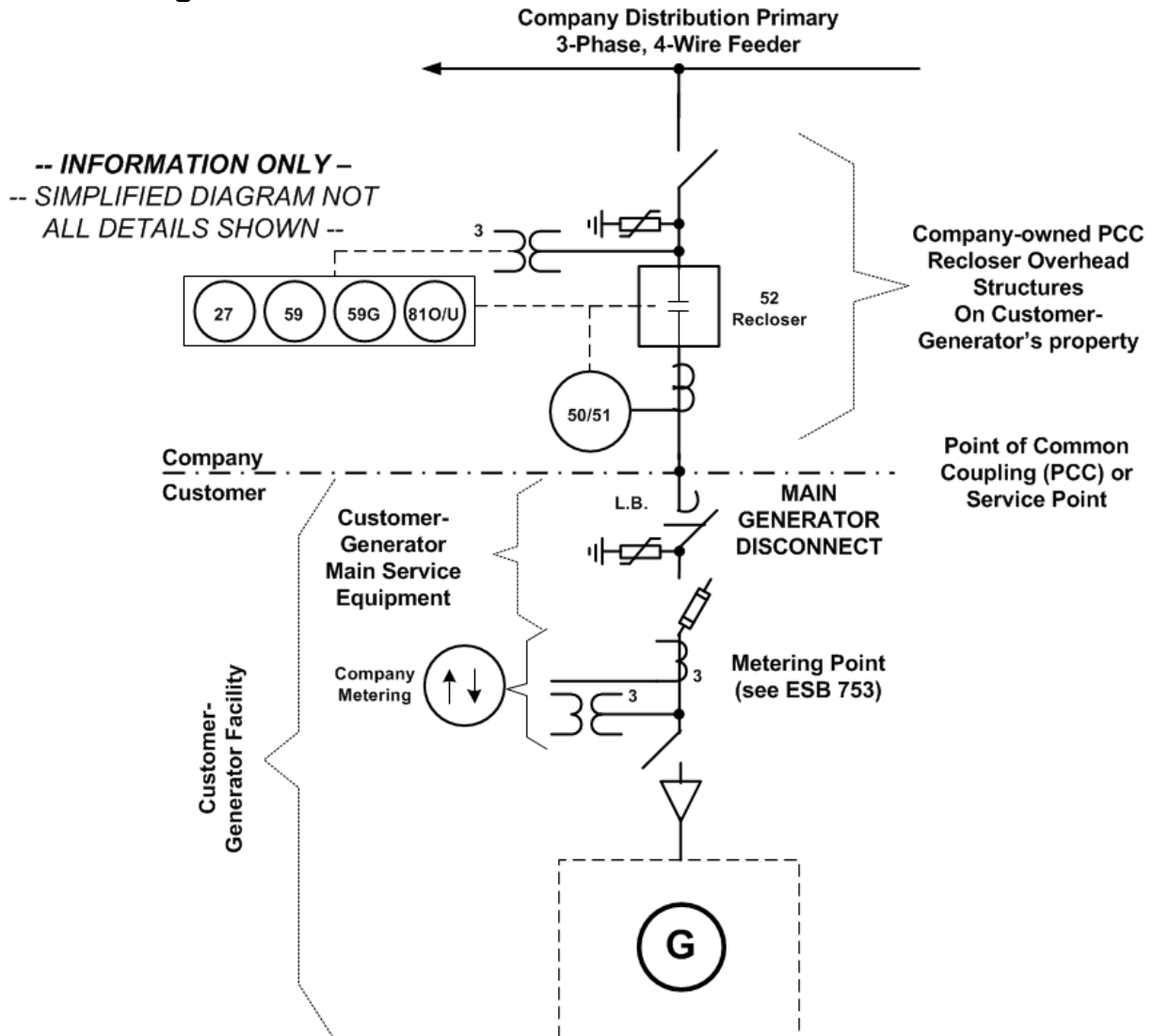

Notes:

The IC will be required to install a Primary Meter Pole service to the Company's specifications on which the Company will dead end the Company's primary service conductors and connect to the main disconnect switch. This point will be the physical PCC. See the Company's ESB 753 for installation specification requirements.

All Company-owned service lateral facilities and equipment on private property will require easements. These easements will be the responsibility of the IC to obtain in accordance with the Company's specific electric service requirements; see ESB 750.

EXHIBIT 6: Net Metering Compliance Verification Checklist

Account Number: _____ **Email:** _____
Customer Name: _____ **Phone #** _____
Last First **Work Phone #** _____
Service Address: _____
Number Street Town/City Zip
Billing Address: _____
Number Street Town/City Zip
Qualified Installer: _____ **License #** _____ **Phone #** _____
Last First (if available) **Cellular #** _____
Address: _____ **FAX #** _____
Number Street Town/City Zip **Email:** _____

✓ **Verify One-Line Diagram (installed equipment)**

_____ UL 1741 Certified Inverter Model _____
_____ Software version _____
_____ Company billing meter s/n _____ Net-meter One Meter Option: **YES** ___ **NO** ___
_____ Inspection received? **YES** ___ Number _____ (attach copy of approval certificate)
NO ___, then stop and await inspection approval.

✓ **Verify Plot Plan (equipment's location)**

_____ "Generator Disconnect Switch" is at agreed location: **YES** ___ **NO** ___.
_____ "Generator Disconnect Switch" is labeled as such: **YES** ___ **NO** ___.
_____ Label is at meter location to identify location of Generator Disconnect: **YES** ___ **NO** ___.

✓ **Verify DG System Is Operating (producing power)**

_____ Verify "Generator Disconnect Switch" is **Open**.
_____ Verify voltage is **zero volts** on DG side of open "Generator Disconnect Switch": **YES** ___ **NO** ___.
_____ **Close** "Generator Disconnect Switch".
_____ Verify DG inverter **alarms** and **voltage present** on utility side of "Generator Disconnect Switch":
YES ___ **NO** ___.

✓ **Restoration of Utility Power Test**

_____ **Open** "Generator Disconnect Switch", **pause at least 1 to 2 minutes**, then **Close** "Generator Disconnect Switch". Record time when "Generator Disconnect Switch" is closed: _____
_____ Record time when **DG Inverter starts** producing power: _____. Is the time between the "Generator Disconnect Switch" closure and when DG Inverter permits synchronization to utility source **greater than 5 minutes**? **YES** ___ **NO** ___

✓ **24-hour Telephone Number Contact**

Name: _____ **Number** (____) _____

Performed by: _____ **signature:** _____ **Date:** _____
Name (Customer's qualified installer)

Witnessed by: _____ **signature:** _____ **Date:** _____
Name (Company witness)

Electric System Bulletin No. 756 Appendix C:

Distributed Generation Connected to National Grid Distribution Facilities per the Massachusetts Standards for Interconnecting Distributed Generation

Version 6.0, 12/04/2019

ESB 756 Appendix C is part of the ESB 750 series

TABLE of CONTENTS

<u>SECTION</u>	<u>PAGE</u>
TABLE of CONTENTS.....	2
1.0 Purpose	4
2.0 Scope	5
3.0 Applicable Codes, Standards, and Guidelines	5
4.0 Definitions.....	7
5.0 Interconnecting Customer Interface Procedures	7
5.1 APPLICATION PROCESS OVERVIEW.....	7
5.1.1 Customer Technical Data Submission	8
5.1.1.1 Control Diagrams	8
5.1.1.2 Interconnection Facility Equipment Data Sheets.....	8
5.1.1.3 Site Plan.....	8
5.1.1.4 Data Required for Energy Storage System Applications.....	9
5.1.1.5 Data Required for Facility or Campus-style Microgrid Applications.....	9
5.2 INTERCONNECTION PROCESS FOR DER NOT ELIGIBLE FOR THE SIMPLIFIED PROCESS.....	10
5.3 OBJECTIVES IN THE APPLICATION PROCESS.....	10
5.4 SPECIAL SYSTEM CONSIDERATIONS.....	12
5.4.1 Secondary Grid and Spot Network Areas	12
5.4.2 Less than 5kV Distribution Systems.....	13
5.4.3 Non-Effectively Grounded Underground and Other Special Systems	13
5.5 INTERCONNECTION CHARGES	13
Table 5.5-1: DER Projects where no EPS upgrades are expected	13
Table 5.5-2: Complex DER Projects.....	13
6.0 Potential Issues Related to Interconnection	14
6.1 GENERAL CONSIDERATIONS	14
Illustration 6.1.5-1: Typical DG Installation Areas on Radial Distribution Feeders.....	16
6.2 SIGNIFICANT EPS CONSIDERATIONS	16
6.2.1 Direct Transfer Trip.....	16
6.2.2 Transmission Ground Fault Detection.....	17
Illustration 6.2.2-1: Simple One Line for Transmission Ground Faults for Typical Substation Transformer Configuration.....	18
7.0 General Design and Operating Requirements.....	18
7.1 GENERAL CRITERIA.....	19
7.1.1 Delivery Voltage	19
7.1.2 Single Phase	19
7.1.3 Three Phase.....	19
7.1.4 Phase Balance and Voltage Tolerance.....	19
7.1.5 Neutral Stabilization, Ground Faults, and Grounding	20
7.2 SERVICE EQUIPMENT AND REVENUE METERING.....	21
7.2.1 Service Equipment Requirements.....	21
7.2.2 Company Revenue Metering Requirements	22
7.2.2.1 ESS paired with DG	22
7.3 TRANSFORMER	23
7.3.1 Secondary Served Customers	23
7.3.2 Primary and Higher Voltage Served Customers.....	23
7.3.2.1 Effectively Grounded, Four-wire Multi-grounded 3-phase Wye EPS:.....	23
7.3.2.2 Not Effectively Grounded, Three-wire 3-phase EPS:	24
7.4 MANUAL GENERATOR DISCONNECTING MEANS	24
7.5 GENERATOR INTERRUPTING DEVICE REQUIREMENTS.....	26
7.5.1 General.....	26

TABLE of CONTENTS

<u>SECTION</u>	<u>PAGE</u>
7.5.2	Local Power Supply Requirements 26
7.6	PROTECTION AND PROTECTIVE EQUIPMENT REQUIREMENTS 27
7.6.1	Type Tested (Certified) Equipment 28
7.6.2	Non-Type Tested Equipment 28
7.6.3	Number of Relays Required..... 28
7.6.3.1	Certified Inverter-based Energy Resource Protection Requirements 28
7.6.3.2	All Non-Certified Energy Resource Protection Requirements 29
7.6.4	Instrument Transformers for Protective Relays 29
7.6.4.1	Current Transformers (CT) 29
7.6.4.2	Voltage Transformers (VT) and Connections..... 29
7.6.5	Protective Relay and Trip Circuit Hard-Wire Requirements..... 30
7.6.6	Protective Relay Test Switch Requirements 30
7.6.7	Voltage Relay Devices..... 30
7.6.8	Frequency Relay Devices 30
7.6.9	Synchronizing Devices 31
7.6.10	Overcurrent Relay Devices 31
7.6.11	Utility Grade Relay and Protective Device Settings and Verification 31
7.6.11.1	Default Voltage and Frequency Set points for all types of Energy Resources 31
	Table 7.6.11.1-1 Utility Grade Relay and Parallel Generation Default Voltage & Frequency Set Points 31
7.6.11.2	Synchronism Check Setting Requirements for all types of Generation 31
	Table 7.6.11.2-1 Relay Settings to Parallel with the Company EPS 32
7.6.11.3	Company-designated Relays and Customer Settings..... 32
7.6.11.4	Company Verification of Relay Testing..... 32
7.6.12	Unintentional Islanding Protection for DER 32
7.6.12.1	General 32
7.6.12.2	Islanding risk mitigation methods required..... 33
7.6.12.3	Certified DER 34
7.6.12.4	Non-certified & voltage or frequency regulating inverters, induction & synchronous machines 34
7.7	MONITORING AND CONTROL (M&C) AT DER FACILITY 35
7.7.1	For Independent Power Producer (IPP) – “Utility Connected Stand Alone” projects (DER with no load)..... 35
7.7.2	For Non IPP - “Behind the meter” projects (DER’s with customer Load) 35
	Table 7.7.2-1: RTU Requirements by Facility Size 35
7.8	VOLTAGE AND FREQUENCY RIDE THROUGH AND CONTROL REQUIREMENTS 36
7.8.1	Voltage and Frequency Ride Through 36
7.8.2	Voltage and Frequency Control 36
	Table 7.8.2.2-1: Default Mode Settings for Inverter-based Utility Interactive DER 36
7.8.3	Return to Service..... 37
	Table 7.8.3-1: Return to Service Parameters for DER 38
8.0	Testing and Commissioning 38
9.0	Operating..... 38
10.0	Power Quality Monitoring 39
10.1	POWER QUALITY COMPLIANCE VERIFICATION..... 39
10.2	POWER QUALITY DISTURBANCE AND MITIGATION 39
10.3	TRANSIENT OVERVOLTAGE/LOAD REJECTION OVERVOLTAGE (LROV) 39
11.0	Facility Audit 40
12.0	Disconnection by the Company (Isolation) 40
13.0	REVISION HISTORY 40
EXHIBITS ATTACHED 40

TABLE of CONTENTS

<u>SECTION</u>	<u>PAGE</u>
EXHIBIT 1: COMPANY REQUIREMENTS FOR PROJECTS NOT ELIGIBLE FOR THE SIMPLIFIED PROCESS.....	42
EXHIBIT 2: REFERENCE MAPS OF NATIONAL GRID MASSACHUSETTS SECONDARY NETWORK EPS AREAS.....	43
EXHIBIT 3: DISTRIBUTION SECONDARY GRID AND SPOT NETWORK DESCRIPTION	44
EXHIBIT 4: RECOMMENDED GUIDELINES FOR RESIDENTIAL AND COMMERCIAL SINGLE-LINE DIAGRAM SUBMITTALS	45
FIGURE 1: SAMPLE RESIDENTIAL PHOTOVOLTAIC DISTRIBUTED GENERATOR INSTALLATION – SINGLE PHASE, NET METERED	46
FIGURE 2: SAMPLE DISTRIBUTED GENERATOR ONE-LINE DIAGRAM	47
FIGURE 3: TYPICAL SYMBOLOGY FOR ELECTRICAL DRAWINGS	48
EXHIBIT 5: RECOMMENDED GUIDELINES FOR FUNCTIONAL SINGLE-LINE DIAGRAM SUBMITTALS	49
FIGURE 4: SAMPLE FUNCTIONAL SINGLE-LINE DIAGRAM	50
FIGURE 5: TYPICAL 3V ₀ REQUIREMENTS FOR LOCAL EPS GROUND FAULT DETECTION	51
EXHIBIT 6: TYPICAL OVERHEAD PRIMARY SERVICE CONFIGURATION IN MA FOR LARGE DER INSTALLATIONS.....	52
EXHIBIT 7: NET METERING COMPLIANCE VERIFICATION CHECKLIST (SIMPLIFIED PROCESS) ..	53

1.0 Purpose

1. Electric System Bulletin (ESB) 756 Appendix C *covers* requirements for interconnecting customers proposing to install a distributed energy resource (DER) system (“Interconnecting Customer” or “Customer”) to National Grid’s (“the Company”) Massachusetts electric power system (EPS) for State jurisdictional projects.
2. ESB 756 Appendix C *does not cover* the technical federal and state transmission operator jurisdictional requirements New England Independent System Operator (ISO-NE) and Federal Energy Regulatory Commission (FERC) for connection to the Company’s transmission EPS, community microgrids, and parallel operated DER systems and on-site generators (OSG) that are covered by the Company’s ESB 756 Appendix A.¹
3. This ESB supplements **ESB 750** and the M.D.P.U.² 1320 Massachusetts Electric Company Nantucket Electric Company d/b/a National Grid Standards for Interconnecting Distributed Generation (MA SIDG; see https://www9.nationalgridus.com/non_html/1320%20-%20DG%20Interconnection%20Tariff_10.01.16.pdf) and provides general technical requirements, recommendations, and assistance to customers regarding DER systems connected in parallel to the Company’s distribution EPS. Note that the MA SIDG does not apply to DER facilities, or group of facilities, having specific requirements under ISO-NE³ Operating Procedures No. 14 and No. 18 and where wholesale DER connections are proposed. Each DER interconnection project will be individually evaluated relative to its unique technical and engineering parameters. As such, the Company reserves the

¹ If deemed as a FERC jurisdictional projects, the Customer will need to apply and work with the ISO-NE (http://www.iso-ne.com/genrtion_resrcs/nwgen_inter/index.html) for interconnection to the distribution system, following the application requirements of the FERC Small Generator Interconnection Procedure (SGIP) and ISO-NE Schedule 23.

² Massachusetts Department of Public Utilities (DPU or M.D.P.U.).

³ Independent System Operator (ISO) for New England (NE); see <https://www.iso-ne.com/>.

right to amend or revise the technical requirements of this document, should it be justified by a project's unique circumstances.

4. ESB 756 and this Appendix C are available from the Company's website at <http://www.nationalgridus.com/electricalspecifications> and in printed form by contacting the Call Center in Massachusetts (see inside cover of ESB 750 for Customer Service Center telephone numbers). However, since printed copies may not reflect the latest updates, please refer to the Company's website for the latest authorized versions.

2.0 Scope

1. This Appendix C to ESB 756 is provided to assist a Customer desiring to interconnect a generator facility to National Grid's EPS to meet requirements for all generating interfacing equipment to be designed, installed, interconnected, tested, and operated in accordance with applicable government, industry, and Company standards.
2. These requirements are limited and apply to only those types of parallel generation and energy storage systems covered by the MA SIDG connected to the Company EPS with a nameplate rating of 5 MW or less including other distributed energy resources (DER) such as facility or campus-style microgrids, and where DER owners, or DER owners as clients of registered aggregators, sign onto a retail tariff with the intent to sell energy or ancillary services to the retail market. For FERC jurisdictional projects connected to the Company Distribution EPS, the technical provisions of this document also apply in conjunction with ESB 756 Appendix A. Where conflicts arise, the technical provisions of ESB 756 Appendix C take precedence.
3. These requirements apply only to those points in which the Customer and the Company have a mutual interest of the DER facility's or premises' wiring service connection to ensure safety to Company employees and the public as well as satisfactory operation, compatibility, and reliability with the electrical supply to others served by the Company's EPS. This includes, but not limited to,
 - the location of the service point and facilities under the Company's exclusive control, such as the Company's metering to be installed at any point on either side of the service point;
 - service lateral;
 - service equipment; and
 - the Company's need to automatically isolate parallel sources of the DER facility from the EPS should there be an unacceptable disturbance, event, or condition within the facility.

Conditions of electric service are based on governmental laws or regulations that determine the Company's authority to provide electric service under their tariffs. See 90.2(B)(5) in the National Electrical Code® and the Company's ESB 750 for more information.

4. For the Company's interconnection process requirements of the MA SIDG, please refer to the retail tariff requirements at the following Company website:
MA: https://www9.nationalgridus.com/masselectric/home/energyeff/4_interconnection-process.asp
5. These requirements may also be applied, at the discretion of the Company, to other methods used to generate electricity in parallel with the Company's EPS, including but not limited to energy storage system (ESS) facilities, regenerative drives used in elevators, and component power inverters used in exercise equipment and any other micro-scale type energy recapture systems.

3.0 Applicable Codes, Standards, and Guidelines

1. The Customer's DER facility shall conform to the latest revision of all local, state and federal codes and national standards that apply, including issued amendments unless the Company has taken exception to such standard. Specific codes and standards applicable to this bulletin include, but are not limited to:
 - Institute of Electrical and Electronics Engineers (IEEE) Std. 1547 "Standard for Interconnection and Interoperability of Distributed Energy Resources with Associated Electric Power Systems Interfaces"
 - Underwriters Laboratories (UL) Std. 1741 "Standard for Inverters, Converters, Controllers and Interconnection System Equipment for Use With Distributed Energy Resources"
 - ANSI/IEEE C2 "National Electrical Safety Code®" (NESCC)
 - NFPA 70 "National Electrical Code®" (NEC)
 - NFPA 70B "Recommended Practice for Electrical Equipment Maintenance"
 - NFPA 70E "Standard for Electrical Safety in the Workplace"
 - NETA-MTS "Maintenance Testing Specifications for Electrical Power Distribution Equipment and Systems"
2. The Customer's DER facility shall also conform to any applicable requirements of the Massachusetts DPU and any local, state, federal and/or other agencies from which a review, approval, or a permit is required.
 - The minimum "fall zone" clearance of wind turbine generators (WTG) shall be in accordance with the local governmental authority having jurisdiction (AHJ) and in any case, shall not be less than 125% of maximum WTG height measured horizontally to the Company's overhead distribution lines.
 - Refer to ESB 750 for additional information regarding specifications for electrical installations. The Customer is responsible for securing and coordinating all required easements and permits for installation of equipment on the proposed site.
3. The Customer shall comply with the latest revision of the appropriate Company ESB or tariff requirements, which cover details for the Customer's electric service installation. These include:
 - **ESB 750** - Specifications for Electrical Installations
 - **ESB 751** - General Requirements Above 600-Volt Service⁴
 - **ESB 752** - Service Above 15,000 volts
 - **ESB 754** - Outdoor Pad Mounted or Vault Enclosed Single and Three Phase Transformer
 - **ESB 755** - Operation & Maintenance Requirements for Services Above 600 Volts
 - **ESB 758** - Primary Service to Metal Enclosed Gear
 - **M.D.P.U. 1320** - Massachusetts Electric Company Nantucket Electric Company d/b/a National Grid Standards for Interconnecting Distributed Generation (MA SIDG)
 - **M.D.P.U. 1316** - Massachusetts Electric Company Nantucket Electric Company Terms and Conditions for Distribution Service
 - **M.D.P.U. 1360** - Massachusetts Electric Company Nantucket Electric Company Net Metering Provision

⁴ ESB 751 Applies regardless of service voltage for DER systems.

- **M.D.P.U 1321** – Massachusetts Electric Company Nantucket Electric Company Qualifying Facility Power Purchase Rate P

Refer to **Exhibits 4** and **5** and **Figures 1** through **3** for information when submitting single-line diagrams to the Company's electronic mail address at Distributed.Generation@nationalgrid.com.

4.0 Definitions

See ESB750, ESB756, and the **MA SIDG** for definitions of special terms. The following terms are defined for the purposes of this document.

1. **Certified:** Equipment that is approved by examination for safety; see NEC Articles 90 and 110.
2. **Certified DER:** A UL 1741 certified inverter.
3. **Distributed Energy Resource:** An energy source, either distributed generation, storage, or a combination of both, parallel connected to an area EPS.
4. **Generator:** Equipment that produces power.
5. **Generator Set** or **Genset:** The singular assembly of an electrical generator and a prime mover.
6. **Line section:** Any EPS circuit segment that can be isolated via an automatic interrupting device such as a sectionalizer, recloser, or circuit breaker on three phase circuits; fuses and cut-out mounted reclosers on single phase grounded circuits.
7. **Non-certified DER:** Any induction or synchronous DER, or a non-UL 1741 inverter.
8. **Prime Mover:** The equipment that drives the generator to output power. For example, in a typical motor operated generator, i.e., M-G set, the motor would be considered the prime mover, or for photovoltaic installations the DC panel arrays on a solar facility would be considered the prime mover.
9. **Recloser:** A line protective device having automatic interruption and controlled reclosing characteristics.
10. **Utility Grade:** Refers to protective device equipment complying with ANSI/IEEE C37.90, ANSI/IEEE C37.90.1 and ANSI/IEEE C37.90.2.

The terms Customer, distributed generator (DG), distributed resource (DR), interconnecting customer (IC), and isolated are defined in the **MA SIDG**.

5.0 Interconnecting Customer Interface Procedures

5.1 Application Process Overview

This section outlines the process for a Customer to receive Company approval to interconnect DER facilities to the Company's distribution EPS.⁵ This process is intended for the following:

1. New DER facilities (as aggregated on the customer side of the point of common coupling (PCC)), that are eligible under the **MA SIDG** process and;
2. Review of any modifications affecting the Company distribution EPS and service connection interface at the PCC of existing Customer DER systems that:
 - (i) Have a nameplate rating in aggregate on the Customer's side of the PCC that exceed the service connection rating;
 - (ii) Are eligible under the MA SIDG process; and

⁵ If the Company approves an application to interconnect a DER facility to the Company's distribution EPS, the terms and conditions of that approval will be set forth in an Interconnection Service Agreement, which is a legally binding document that can only be changed by a written document signed by both parties. See Exhibits G, H and I in the MA SIDG.

- (iii) Have been interconnected to the Company EPS where an existing retail interconnection agreement and/or power purchase agreement between the Customer and the Company is in place.

This application process and its requirements do not apply to generation equipment that will never be allowed to operate in parallel with the Company Distribution EPS. For example, this process does not apply to emergency standby generators with break-before-make transfer switches and any other generation sources that operate independently of any connection to the Company Distribution EPS and have no provision for such connection (even for a short period of time).

As stated above, this application process is mandated by the Massachusetts DPU for customer generation equipment that will be connected to the Company Distribution EPS on a full or part time basis; see the **MA SIDG**.

5.1.1 Interconnected Customer Technical Data Submission

The Customer shall submit, at the time of application, all relevant documentation as specified in the **MA SIDG**. The Company reserves the right to request additional information as needed specific to the interconnection of Customer equipment including, but not limited to, three-line diagrams, control diagrams, equipment test reports and other information; see the Company's ESB 750 and 751. The Customer shall provide proof of land ownership or rights to land use.

5.1.1.1 Control Diagrams

The Customer shall submit all control diagrams ("DC control schematics") of the equipment associated with the interconnection protective system. Control diagrams depict all logic used to control the interconnection protective devices. Relay logic diagrams shall be provided for utility-grade relay functions meeting utility requirements.

5.1.1.2 Interconnection Facility Equipment Data Sheets

The Customer shall submit all technical data associated with the specific distribution, protection, and generation equipment included in the project. Submitted documentation shall highlight product numbers and information for the specific equipment/devices that will be installed as part of the project. Examples of required documentation specific to DERs include but are not limited to:

- Rotating machine impedance parameters for modeling
- Inverter-based system models and validation test data
- Inverter islanding detection information, including brief description of islanding detection method, parameters monitored, parameters perturbed (for active islanding methods), and whether positive feedback-based methods are to be used
- For 5 MW or greater inverter-based DER, Customer is required to provide stability model. Please see ("[Guideline for Modelling Inverter-Based DER Greater Than or Equal To 5MW](#)").

5.1.1.3 Site Plan

A site plan shall be submitted showing the location of major customer equipment, the Company equipment to be installed on site, and site details that will be helpful to define accessibility of the site. The site plan shall show the following equipment at minimum:

1. Interfacing transformer(s)
2. Interrupting device(s)
3. Isolation device(s) (e.g. generator disconnect)
4. Point of common coupling (PCC)
5. Company pole number nearest the proposed PCC
6. Company line extension to site and from nearest Point of Interconnection
7. Restricted accesses, fences, gates and access controls

8. Existing and proposed Access road(s) including, at a minimum, road material, surface loading criteria, and dimensions to confirm Company personnel and equipment access requirements are met.
9. Generator location(s)
10. Existing service(s)

Site plans shall be to scale with approximate distances indicated, north arrow and scale bar. In addition to site plan, the Company may request an assessor survey map to determine property lines, wetlands and easements. The customer's site plan shall indicate proposed Utility equipment or pole locations for coordination. Locations of company equipment shall be noted as: "For informational purposes only. Final location determined by Utility". Final location of Company equipment is determined by the Company, typically during the design and construction phase.

5.1.1.4 Data Required for Energy Storage System Applications

For applications having ESS proposed, additional information may be required at the time of application for interconnection such as but not limited to:

- Method of ESS connection whether: (1) ESS directly connected to utility EPS; (2) Distributed Generator (DG) and ESS DC coupled; (3) DG and ESS AC coupled; and (4) ESS on load side of service point and utility revenue meter with the premises load, as applicable to the proposal.
- Sequence of operation for the ESS' charging and discharging capabilities and the maximum ramp rate in Watts/second.
- Non-UL 1741 listed inverters will require a utility intertie relay with the appropriate IEEE 1547 functions, settings, and islanding protection according to the Company's [ESB 756](#) jurisdictional requirements.
- Service configuration and revenue metering provisions shall meet the Company's [ESB 750](#) and its applicable supplements.

5.1.1.5 Data Required for Facility or Campus-style Microgrid Applications

Additional information may be required at the time of application for interconnection specific to the facility or campus-style microgrid proposed operation. Facility or campus-style microgrid applications have certain characteristics described here, all of which fall under the U.S. Department of Energy (DOE) definition.⁶ Such microgrids consist of one or more buildings and the relationship with the interconnected utility is characterized as either a single customer-of-record or a single operating entity on one property. These can take several forms such as:

1. A single building under a common property owner with a common customer account. The microgrid has generation resources that can operate in parallel with the electric grid or in island mode.
2. A single building under a common property owner/customer, with multiple direct-metered accounts. The microgrid is configured so that all customers within the building can share the benefits of DER.
3. Multiple buildings owned by a common property owner where microgrid loads and DER are tied with common electric distribution facilities generally not owned by the utility.

These facility or campus-style microgrids are premises wiring systems governed by the National Electrical Code (NEC) as adopted by the local jurisdictional authority.⁷

⁶ The U.S. DOE defines a microgrid as a "group of interconnected loads and distributed energy resources (DER) with clearly defined electrical boundaries that acts as a single controllable entity with respect to the grid [and can] connect and disconnect from the grid to enable it to operate in both grid connected and island mode."

⁷ See NFPA 70-2017 NEC for installation requirements of premises wiring systems related to microgrids.

5.2 Interconnection Process for DER Not Eligible for the Simplified Process

The process for installation of those facilities the Company deems necessary for interconnection of the DER system will be specified by the Company in accordance with the **MA SIDG** in response to the Customer's DER interconnection application. See **Exhibit 1** for Company requirements for Projects not Eligible for the Simplified Process.

5.3 Objectives in the Application Process

1. Parallel operation of a generator becomes integrated with the Company EPS, in which the Customer and the Company have a mutual interest. The interconnection must preserve the safety, reliability, security, power quality, and operational efficiency needs of the Company's EPS. This is necessary to ensure safety to the public and to Company employees and satisfactory operation and compatibility with the electrical supply to others. The steps and timing requirements of the application process are identified within the **MA SIDG**.
2. Additional site-specific requirements may be indicated once the supply voltage, service arrangement, location, and generation purpose is determined, where such Customer proposed purpose can be either:
 - peak shaving,⁸
 - net metering for solar, wind, anaerobic digestion, small hydroelectric, agricultural or other projects in accordance with the Company's net-metering tariff, M.D.P.U. 1360,
 - ESS paired with DG, or
 - export energy for a QF with an agreement for sales⁹ all according to the Company's tariff provisions.
3. For new electric service or modifications to **the electric service connection** to accommodate the Customer's **DER system**, refer to the Company's latest revision of ESB No. 750, Specifications for Electrical Installations. The Customer will be responsible for any permitting and conformance to the latest revision of all local, state and federal codes and national standards that apply. For example:
 1. Under MA and municipal building code requirements the Customer will need to provide evidence of electrical inspection approval from their local municipal code enforcement agency.
 2. The Customer will also be responsible for any additional costs associated with work completed by another entity (such as Telco set poles). The Customer should be aware that project construction schedules can be severely impacted by this other work.
4. When considering a DER interconnection arrangement, an M.D.P.U. 1320 Exhibit A application or Exhibit B pre-application and/or Exhibit C application must be submitted to the Company's Distributed Generation Services department.
5. Any subsequent sale of an On-Site Generator (OSG) facility covered by the requirements of the MA SIDG of the original retail Customer's facility will require the new

⁸ Peak shaving generation is Customer-owned generation operated in parallel with the Company to reduce a Customer's electrical demand. Unlike net metering, peak shaving generation is not permitted to flow into the utility supply system upstream of the billing meter and will require the installation of protection devices to limit such power export onto the Company's EPS. The Company's revenue metering is detented in this case to prevent reverse billing meter registration.

⁹ An Agreement for Sales of Export Energy for a QF under a MA SIDG application may be made per the Company's M.D.P.U. 1321 electricity tariff and is a Power Purchase Agreement.

owner to establish a separate interconnection agreement (M.D.P.U. 1320 Exhibit F and/or G) for the generation and to comply with these parallel generation requirements.

6. Refer to:

- The steps to install distributed generation in Massachusetts as specified in the MA SIDG; see Section 3.0 of M.D.P.U. 1320 (https://www9.nationalgridus.com/non_html/Interconnect_stds_MA.pdf),
- The Company's Distributed Generation Services **electronic mail address** as follows for inquiries: Distributed.Generation@nationalgrid.com, and
 - The Company's (www.nationalgridus.com) "Distributed Generation" web site at https://www9.nationalgridus.com/masselectric/home/energyeff/distributed_generation.asp for information and forms listed below (from M.D.P.U. 1320) https://www9.nationalgridus.com/non_html/Interconnect_stds_MA.pdf) when making an application with the Company:
 - Simplified Process application form and service agreement (Exhibit A)
 - Pre-Application Report Form (Exhibit B)
 - Expedited and Standard Process application form (Exhibit C)
 - Supplemental Review Agreement for those projects which have failed one or more screens in the Expedited Process (Exhibit D)
 - Impact Study Agreement under the Standard Process (Exhibit E)
 - Detailed Study Agreement for the more detailed study under the Standard Process which requires substantial System Modifications (Exhibit F)
 - Interconnection Service Agreement for Expedited and Standard Process (Exhibit G)
 - Agreement Between the Company and the Company's Retail Customer (Exhibit H)
 - Landowner Consent Agreement (Exhibit I)
 - Schedule Z – Additional Information Required for Net Metering Service
- The following Independent System Operator-New England (ISO-NE) requirements apply under this bulletin:
 - DER projects 60 kW or larger that will export power require asset registration by the Company's Customer Energy Integration (CEI) department to ISO-NE.
 - DER projects greater than 1 MW but less than 5 MW will require a notification by the Company's CEI department to ISO-NE via Attachment 4 under ISO-NE Planning Procedure (PP) 5-1.
 - DER projects greater than or equal to 5 MW will require a review of transmission system impacts and a Proposed Plan Application (PPA) filed with ISO-NE. Refer to ISO-NE PP 5-1.

7. The application process and attendant services are offered by the Company on a non-discriminatory basis to any Customer. As part of the process, the Company may identify the need for detailed engineering studies, EPS upgrades and additional protection requirements. As allowed by the Massachusetts DPU, the costs of the detailed study and upgrades are the responsibility of the Customer. If the Customer makes significant changes in the design or scheduling of their DER system, then any previous information furnished by the Company to the Customer is subject to review and possible change, which may cause a delay in service.

8. The following website contains the Company's application of the MA SIDG net metering rules: https://www.nationalgridus.com/masselectric/home/energyeff/4_net-mtr.asp.

5.4 Special System Considerations

The Company will identify in the DER impact study any systems that may require special considerations including but not limited to those in this section.

5.4.1 Secondary Grid and Spot Network Areas

1. When applying for a DER interconnection within the Company's secondary area network and secondary spot network EPS located in the downtown districts of Brockton, Lynn, and Worcester in Massachusetts, DER installations on distribution secondary network systems may require a study to be undertaken to ensure the DER facility does not degrade the reliability, power quality, safety, or operation of the Company's network system. For these areas, the study may be required regardless of DER size, type, or complexity. Therefore, customers in the downtown districts of Brockton, Lynn, and Worcester **should check the** National Grid Website: "Area Network Maps" [http://www.nationalgridus.com/masselectric/business/energyeff/4_networkmap.asp]. **If that street location is highlighted in red (or near) the red line, then contact the Company at** Distributed.Generation@nationalgrid.com to determine if the proposed location is served by a distribution secondary network system. This should be done while the project is still in the planning stage, and certainly before purchasing equipment or beginning installation. The Company will review the Customer's plans and discuss options with the Customer. Refer to attached **Exhibit 2** for area maps locating the Company's secondary network service areas.
2. Unlike radial distribution systems that deliver power to each customer in a single path from source to load, underground secondary area network systems deliver power to each customer through a complex and integrated system of multiple transformers and underground cables that are connected and operate in parallel; refer to attached **Exhibit 3** for more information.
 1. Connecting customer DER to the low voltage secondary networks can cause the power flow on network feeders to shift (i.e., reverse) causing network protectors within the network system to trip open. The Company's network system protection is designed without time delay. Synchronous generators are not permitted to interconnect to the Company's secondary voltage network systems. Small induction and inverter-based generators are considered on the secondary voltage network systems on a case-by-case basis.
 2. Spot networks are similar to area networks except they serve a single premise. Connection of DER systems on the spot networks are only permitted if the secondary bus is energized by more than 50% of the number of installed network protectors as required by the current version of the IEEE Std. 1547.
 3. As a result, the connection of customer DER facilities on networks **(i)** poses some issues for the Company to maintain adequate voltage and worker safety and **(ii)** has the potential to cause the power flow on network feeders to shift (i.e., reverse) causing network protectors within the network grid to trip open. Therefore, to ensure network safety and reliability additional information will be required for the Company's engineering analysis such as:
 - Customer's existing¹⁰ or proposed electric demand profile showing minimum load during peak generation time,
 - Customer's expected generation profile shown for a 24-hour period and typical seven (7)-day duration based on nameplate generation rating, and

¹⁰ In addition, the Company may need to install recording equipment at all metered electricity users to determine the total demand of the building's network service when obtaining the service connection's electric demand profile. The cost to the Customer will be according to the Company's electric customer load survey flat rate and charged in accordance with the terms of the MA SIDG.

- Customer’s complete electric service single-line diagram showing the configuration of the proposed generation and other metered tenants, if any, up to the service point supplied by the Company’s secondary network EPS.

5.4.2 Less than 5kV Distribution Systems

Due to the existing limitations and company requirements for 4 kV systems, DER interconnections equal to or greater than 150 kW that are proposed to interconnect to the 4 kV EPS require a System Impact Study. Any DER customers proposing to interconnect greater than 300 kVA, are no longer be permitted to interconnect to the 4 kV system.

5.4.3 Non-Effectively Grounded Underground and Other Special Systems

The Worcester high tension (HT) system is a high impedance grounded, non-effectively grounded distribution system and has a mix of complex relaying schemes including directional and pilot wire protection schemes. Other portions of National Grid’s system are underground (non-network) systems and have similar complexities that may require impact study regardless of facility size. All interconnections to these systems shall be non-effectively grounded with zero sequence overvoltage (59N) ground fault protection, which commonly requires external relaying – requirements for which are determined in the impact study. Interconnections proposed to connect to this system and portions of other systems built similar to this one may require engineering analysis in accordance with the company’s Tariff regardless of size.

5.5 Interconnection Charges

Customers shall be subject to charges for interconnection costs. To permit interconnected operations with a Customer, the Company may incur costs in excess of those it would have incurred had the Customer taken firm service. These costs, called interconnection costs, are directly related to the installation of those facilities the Company deems necessary for interconnection. They include initial engineering evaluations, purchase and installation of additional switching, transmission, distribution, and communication equipment at Company’s facilities, safety provisions, engineering and administration. These costs shall be paid in full by the Customer prior to commencement of service in accordance with the Company’s tariffs, M.D.P.U. 1320 and 1316. For typical Company interconnection cost items expected in DER projects that will be defined in either an Impact or a Detailed Study, see the following two tables, which are not intended to be all inclusive. Costs will be determined according to the Company’s electricity tariff and the MA SIDG.

Table 5.5-1: DER Projects where no EPS upgrades are expected

Item No.	Typical Company Support Activities Attributed to Customer's Project (Requiring Charges to the Customer)
1	Engineering acceptance review of Customer's construction design submittals where the Company has mutual interest such as service connection facilities, meter mounting provisions, Company-designated protective devices and control schemes according to the Company's ESB 750 series.
2	Revenue metering equipment changes/additions.
3	Field audit of Customer installation to accepted design.
4	Field compliance verification - witness tests of Customer protective devices coordinating with the Company Distribution EPS.
5	CEI Project Management

Table 5.5-2: Complex DER Projects

Item No.	Typical Company Support Activities Attributed to Customer's Project (Requiring Charges to the Customer)
1	Company Distribution EPS upgrades (e.g., Current Limiting Fuses, Primary Conductors, Line Reclosers, Switches, Voltage Regulators, Capacitors, etc.) as a result of DER impact.
2	Where Local EPS anti-islanding protection is required, Direct Transfer Trip (DTT) transmit addition to Distribution EPS substation feeder breaker (and/or Line Recloser) for DER impact on distribution feeder.
3	Where Company-provided Radio Communications can be applied, additions to support DTT equipment at Distribution EPS substation feeder breaker (and/or Line Recloser) for DER impact on distribution feeder.
4	Where Local EPS feeder selectivity may require prompt control measures for DER impact on distribution feeder operations, EMS-RTU (analog status & control) addition at the DER facility.
5	Service Connection modifications and additions for DER impact on the Company Distribution EPS.
6	Revenue metering equipment changes/additions.
7	Engineering acceptance review of Customer's construction design submittals where the Company has mutual interest such as service connection facilities, meter mounting provisions, Company-designated protective devices and control schemes (e.g., DTT receive package installation at DER) according to the Company's ESB 750 series.
8	Field audit of Customer installation to accepted design.
9	Field compliance verification - witness tests of Customer protective devices coordinating with the Company Distribution EPS.
10	Project Management (CEI, Distr. Line, Distr. Station, etc.)

6.0 Potential Issues Related to Interconnection

6.1 General Considerations

1. Customer generation connected to the distribution system can cause a variety of system impacts including steady state and transient voltage changes, harmonic distortion, and increased fault current levels. Parallel generation systems, which located individually on higher capacity feeders may not cause very serious impacts, can, on weaker circuits, in aggregation or in special cases (such as lightly loaded networks), significantly impact the Company's distribution EPS.
2. An Impact Study, and a Detailed Study in some cases, is needed to identify the severity of system impacts and the upgrades needed to avoid problems on the Company EPS. Typically, an Impact or Detailed Study will be performed by the Company to determine if the proposed generation on the circuit results in any relay coordination, fault current, and/or voltage regulation problems.
3. There is a wide range of potential issues associated with the interconnection of DER facilities to the Company Distribution EPS including, but not limited to:
 - a. Impact on step voltage regulation equipment
 - b. Increased fault duty on Company and Customer protective devices and equipment
 - c. Interference with the operation of protection systems
 - d. Harmonic distortion contributions
 - e. Voltage flicker
 - f. Ground fault over voltages
 - g. Risk of islanding
 - h. System restoration
 - i. Power system stability
 - j. System reinforcement
 - k. Metering

I. Arc flash

4. It is important to scrutinize the interconnection of Customer DER systems to the Company EPS so that any negative impacts to the Company EPS performance can be avoided without degradation of EPS safety and reliability. It is the intent of any Company study in accordance with the MA SIDG requirements when applicable to avoid negative power system impacts by identifying the particular type of impact that will occur and determining the required equipment upgrades that can be installed to mitigate the issue(s).
5. In general, DG facilities connected to various locations on the radial distribution EPS (see Illustration 6.1.5-1) are initially evaluated for the maximum possible DER capacity under ideal situations that can be installed on the Company's EPS through technical screens. Where initial technical screens identify concerns on the Company's EPS, site specific system studies (e.g., available short circuit current contributions, minimum network loading in light loading seasons, voltage regulator interactions, etc.) will be required and will identify the interconnection requirements.

Illustration 6.1.5-1: Typical DG Installation Areas on Radial Distribution Feeders

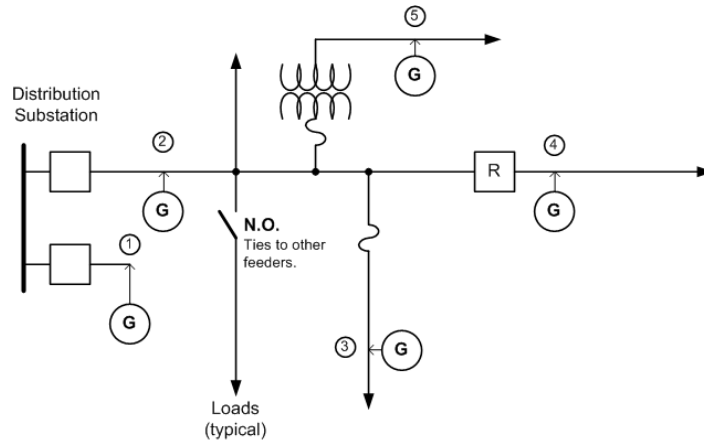

“O” - DG Interconnection Location Point on Feeder

1. Express (dedicated) radial feeder
2. Feeder Main
3. Feeder Branch protected by fuse
4. Sectionalized Feeder Main
5. Feeder Branch protected by fuse with ratio transformer

6. DER saturation, such that it becomes technically infeasible to operate on the distribution feeder or line section, becomes problematic when multiple proposed projects or additional proposed projects are submitted in excess of the designed capacity of major EPS infrastructure. The Company will identify DER saturation in initial screening reviews and in the results of impact studies for DER applications. Studies will be more complex and accommodating interconnections will likely require more involved infrastructure development, costs, and duration to construct.
 1. The EPS substation bus voltage regulation, transformer capacity, and high voltage side protection may be impacted by large DER systems and the Company may specify interconnection to a higher voltage EPS, which allows for continued growth of small DER on the Company’s Distribution EPS (e.g. residential solar).
 2. On single-phase radial distribution systems, generator interconnections with aggregate generator nameplate ratings over 50 kVA may require three-phase service and will be determined by the Company on a case-by-case basis.
7. The Company’s distribution substations are subject to fault duty limitations. Adding generation to the Company Distribution EPS increases the amount of fault current imposed on the substations and equipment on the feeder(s). Exceeding the fault duties of equipment and devices at the substation(s) and on the feeder(s) as a result of DER facilities will not be permitted. Where the equipment fault duty ratings have been reached or exceeded, alternate methods of interconnection shall be explored or equipment shall be replaced at the expense of the Customer with comparable equipment of the appropriate withstand and/or AIC rating.
8. Normally, one service is provided to the customer according to the Company’s electricity tariff, **M.D.P.U. 1316**. However, under specified conditions, multiple service facilities may be supplied to the Customer from a Company Distribution EPS. The interconnection of multiple services shall be specified by the Company within the Company’s operating practices and electric service requirements.¹¹

6.2 Significant EPS Considerations

6.2.1 Direct Transfer Trip

¹¹ See Section 3 in the Company’s ESB750 for more information on multiple service requests.

IEEE 1547 requires any DER on a distribution feeder to detect and be tripped offline within two (2) seconds upon formation of an island from the area EPS. *An island is a condition in which a portion of an area EPS is energized solely by one or more Local DERs while it is electrically separated from the rest of the area EPS.* There are some cases where a DER's on-site equipment (such as voltage and frequency relaying or islanding detection) cannot reliably detect utility islands. Where the Company determines that a significant risk of islanding exists, direct transfer trip (DTT) may be required. DTT typically requires utility substation modifications to send a signal to trip the DER facility offline when the substation breaker opens. This also typically requires the Customer to lease a communication medium between the substation and the DER facility, as well as install a receiver and tripping device in their facility. DTT has inherent high costs and physical limitations associated with equipment installation due to the typical leased telecommunication line requirement at the EPS source and at the generator(s), as well as required utility substation modifications. The initial and recurring costs for DTT are at the expense of the Interconnecting Customer. See section 7.6.12 for more detail on when DTT may be required, which includes but is not limited to islanding

6.2.2 Transmission Ground Fault Detection

The addition of generation sources to distribution feeders can result in the backfeeding of the substation transformers, effectively turning a station originally designed for load into a generation step-up transformer. The Company's most common distribution substation transformer is ungrounded on the transmission side. Due to the transformer's configuration,¹² it cannot contribute zero sequence ground fault current to single line to ground faults on a transmission line, and the voltage on the unfaulted phases rises significantly and rapidly. These over voltages have the potential to exceed insulation levels of the station and transmission line equipment, and maximum continuous operating voltage of surge arresters. This situation can also leave transmission ground faults energized by the distribution-connected DER. Zero sequence voltage protection (commonly referred to as "3V₀") on the primary side of the transformer is required in order to detect these overvoltage conditions. This 3V₀ protection will disconnect the generation from the substation transformer, and stop the generation and transformer from contributing to the transmission-side overvoltage condition.

If the Company determines there is a likelihood of a zero sequence overvoltage event, transmission ground fault detection equipment and substation modifications may be required.

¹² *A common substation transformer configuration is delta on the transmission side and wye-grounded on the distribution side. There are other transformer configurations for which zero sequence continuity is broken and/or the DER is unable to reliably detect and trip offline for transmission ground faults. The Company determines when and which type of transmission ground fault detection is required based on the substation configuration on a case-by-case basis.*

Illustration 6.2.2-1: Simple One Line for Transmission Ground Faults for Typical Substation Transformer Configuration

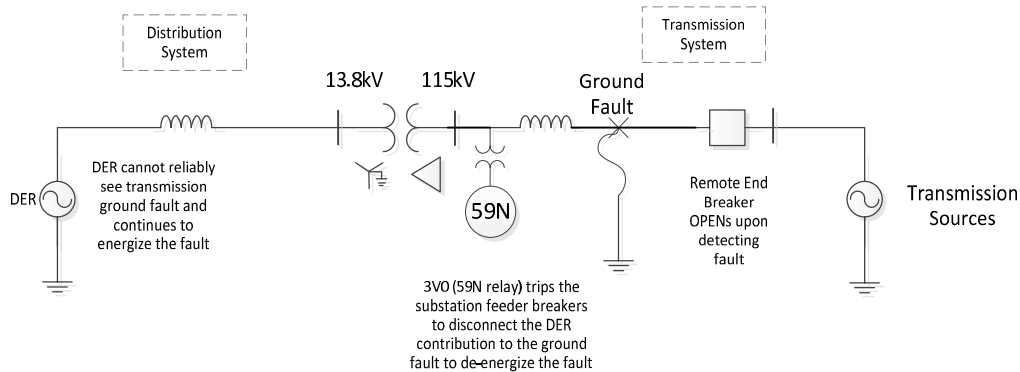

Illustration 6.2.2-1 shows an example transformer configuration for which it is difficult for distribution-connected DERs to detect and trip for transmission ground faults. Where the DER can contribute to this condition without tripping on the 88% undervoltage trip point, $3V_0$ may be required to be installed at the substation. Three voltage sensors (typically coupling capacitor voltage transformers (CCVT), are connected to the transmission side of the utility substation transformer. These voltage sensors are wired to a 59N relay (“ $3V_0$ ” or zero sequence overvoltage function), which trips the DER offline via utility breakers in the substation. This helps de-energize the ground fault from all sources. (Not all details or configurations are shown. Some substations may require protection for detecting transmission ground faults other than $3V_0$, such as scheme modifications, transformer replacement, or teleprotection systems). Customers should be aware that these modifications to the Company’s substations require significant cost and time to install. The cost and time requirements are provided in the impact study according to the MA SIDG and the Company’s Electric Tariff when performed for the Interconnecting Customer.

7.0 General Design and Operating Requirements

From the perspective of interconnection, there are three main types of customer generation systems that interface to the Company’s Distribution EPS. These include:

- Induction Generators
- Static Power Converters (inverter-based)
- Synchronous Generators

Each type has its own specific characteristics regarding synchronization equipment, protective functions, starting practices, and electrical operating behavior. There may also be additional specific requirements that may be identified as part of any impact study that is performed for a specific DER system and/or location as part of any Impact or Detailed Study that is performed for a specific location.

For the purposes of this bulletin, any reference to DER ratings herein refers to the nameplate rating of the generation. Equipment nameplates shall meet ANSI standards.

- For inverter based generation, this shall refer to the nameplate rating of the inverter(s). De-rating of inverter-based DER shall only be considered if the equipment is provided by the Customer’s manufacturer with a permanent means of reducing the rated output, and so marked with an equipment nameplate stating the de-rated output.
- For rotating machines, this shall refer to the nameplate rating of the electric generator (as opposed to the nameplate rating of the generator-set). De-rating of rotating machine generators by their prime mover capabilities shall not be permitted.

- Equipment nameplates shall meet ANSI standards. De-rating of inverter based DER shall only be considered if the equipment is provided by the Customer's generator manufacturer with a permanent means of reducing the rated output, and provided with an equipment nameplate stating the de-rated output. De-rating of DER equipment shall be evaluated for acceptance on a case-by-case basis, with consideration given to specific project conditions, and will be accepted at the discretion of the Company.

For facility or campus-style microgrid connections, DER interconnection equipment, protective systems and microgrid controllers connected at the PCC to the Company's EPS are to be designed and operated according to the Company's requirements in this bulletin as well as to applicable codes and industry standards. Facility or campus-style microgrids may be permitted to automatically trip their PCC isolation device in order to island and serve the premises load; however, this device is required to be blocked from closing until authorized to do so by the Company. The control scheme that will disconnect and reconnect the facility or campus-style microgrid from the Company's EPS must be reviewed and approved by the Company through the MA SIDG process and is subject to witness testing and/or periodic testing as necessary. These situations will require that specific operating protocols to ensure that customer safety and the overall EPS safety and reliability are not in any way compromised.

7.1 General Criteria

The interconnection of all DER systems in parallel with the Company's EPS requires safeguards for synchronization and back feed situations in accordance with the **MA SIDG**. Each specific connection must be studied with respect to size, type, and the nature of the Company's Distribution EPS at the POI. Only the results of a specific study can indicate the suitability of a given generator connection to the Company's Distribution EPS and its possible economic viability. See the **MA SIDG** for detailed requirements.

7.1.1 Delivery Voltage

The Company will designate the type of service and delivery voltage based on the location of the Customer and the size and character of its proposed DER.

7.1.2 Single Phase

Single phase DER system connections to the Company's EPS under 600 volts present power quality and phase balance challenges. Single phase connections shall have these minimum characteristics:

- Nameplate rating of a single generator or group of generators equal to or less than 50 kVA unless otherwise specified by the Company on a case-by-case basis.
- Configured as a three-wire, line-to-line with neutral, or line-to-neutral with adequate load balance.
- A dedicated service lateral with a dedicated transformer, when required by the Company.

7.1.3 Three Phase

Other than permissible single phase connections, three phase connections are required. The aggregated nameplate rating of all DER systems operating in parallel with the Company's EPS on the premise equal to or greater than 5 MW according to the MA SIDG for facilities, or group of facilities, have specific requirements under ISO-NE Operating Procedures No. 14 and No. 18. Refer to ESB 756 Appendix A for additional information in these cases and where wholesale DER connections are proposed.

7.1.4 Phase Balance and Voltage Tolerance

1. The Customer's DER facility shall permit equal current in each phase conductor at the service point or PCC. Voltage unbalance resulting from unbalanced currents

shall not exceed 2% and shall not cause objectionable effects upon or interfere with the operation of the Company's facilities and service to others. This criterion shall be met with and without generation.

2. The interconnection of the DER facility shall not affect the Company's nominal voltage delivery at the PCC by greater than 3%.

7.1.5 Neutral Stabilization, Ground Faults, and Grounding

Multi-grounded distribution area EPS:

1. An effectively grounded system with respect to the Company's EPS must be provided to ensure neutral stability, facilitate ground fault detection, and avoid distribution circuit over voltage during accidental isolation of the Company's area EPS from the Company's main system. This may require an additional ground source see Section 7.3 for acceptable effective grounding options.
2. Contributing to ground faults on the Company's distribution EPS can desensitize the relays at the Company's substation. The effects of such grounding on the Company's ground relay sensitivity shall be limited. The Company requires ground fault protection on any system that can be a generation source and to protect transformers that can be paralleled and supplied from two sources. When generator tripping is needed to sense ground faults on the Company's distribution EPS:
 - The winding arrangement of the Customer's DER facility transformer and the generator winding shall be such that the Company's system remains effectively grounded (see Section 7.3).
 - The Company may require that the grounding impedance be limited to the highest value suitable for neutral stabilization, or to limit generator ground fault contributions. Contribution to the faults on the Company's distribution EPS can desensitize the relays upstream of the Customer's interconnection. For that reason, it is required that the Customer provide a means to install a grounding reactor/resistor within their facility to limit the ground fault current. Where possible, this shall be limited to three times the generator rating and limit the rise of ground fault current at the point on the high voltage (primary) level nearest the proposed service point by no more than 10%. The grounding reactor/resistor shall not violate the effectively grounded system requirements. The impedance of the grounding reactor/resistor will be specified by the Company. If the 10% criterion is not met with the grounding impedance, other methods, upon Company acceptance may be required by the Customer to mitigate the increase in fault current.
3. Distribution circuits may have unbalanced loads (i.e. single-phase loads) which result in neutral currents on equipment connected to multi-grounded circuits. Customers installing grounding equipment (i.e. grounding reactors, grounding transformers) are encouraged to consider this unbalance current when designing neutral-connected equipment where there is no transformer isolation from the Company's EPS. The Company recommends the Customer consider a minimum 100A continuous current rating (or the actual unbalance current, whichever is greater) for 15kV class-connected grounding reactors, and similar equipment parameters for other voltages.

Non-effectively grounded area EPS :

Where the Customer is permitted to interconnect through an ungrounded source, a 59N (3V₀) scheme may be required on the primary (utility) side of the accepted ungrounded source (ungrounded transformer serving the DER system, or generator as applicable) (see Figure 5) to detect utility-side ground faults. Refer to Section 7.3.1 for further discussion on service transformer requirements.

It is Customer's responsibility to detect and trip the facility for ground faults on the Company's distribution EPS – the Customer shall not rely on Company equipment for the protection of customer equipment (e.g. grounding transformer).

7.2 Service Equipment and Revenue Metering

7.2.1 Service Equipment Requirements

1. The Customer shall provide service entrance equipment as a part of their installation; see the Company's ESB 750. The Customer's service equipment shall be rated, at a minimum, for the maximum fault current available from the Company EPS and their own contribution from the generator(s), motors, etc.
2. **Marking:** The Customer shall install and maintain clearly marked permanent labels in accordance with the NEC, MA SIDG and the Company's applicable ESB series requirements. All Utility required marking shall be preprinted or engraved (no hand marking), have a minimum 5-year warranty for indoor or sheltered applications and have a minimum of 25-year warranty for use in outdoor applications. Labels shall be replaced when they no longer meet the legibility requirements of ANSI Z535.4. Labels shall be UL969 compliant. Materials used shall be weather resistant, UV stabilized and suitable for the environment where it is installed. Labels may be of engraved plastic, metallic foil, or polymer plastic mechanically or adhesive applied. For labels using adhesive, ultra-high strength bond adhesive shall be required. Data sheets shall be provided to indicate compliance with labeling requirements.

Exception: Residential installations $\leq 25\text{kW}$ with feed-through type meters may have labels with a minimum 5-year warranty regardless of location.

In addition to NEC required marking, the following Utility requirements apply:

The utility meter enclosure shall be labeled with the following: "WARNING: MULTIPLE POWER SOURCES" or "WARNING: DUAL POWER SOURCE" as applicable.

- The utility meter sockets shall be labeled as follows,¹³ where applicable:
 - Utility Service Meter
 - Utility [DER Type] Sub-Meter, where "DER Type" shall be designated by generation type as follows:
 - "PV Generation" or other type Generation as required per Tariff, or
 - Storage
 - The Interconnecting Customer's AC utility disconnect switch shall be labeled "AC DISCONNECT".
 - If the AC utility disconnect switch is not adjacent to the meter and/or PCC, the Interconnecting Customer shall provide marking as to the location of the switch.
 - All Interconnecting Customer owned meters shall be labeled "CUSTOMER-OWNED METER"
3. For large Customers with aggregate generation equal to or greater than 500 kW, refer to the typical primary overhead service configuration requirements in **Exhibit 6**.
 4. For situations where a higher voltage service connection is required, refer to the Company's ESB 752, 753, or 758 as applicable.

¹³ Some installations may require multiples of the above meters depending on the incentive mechanism. Where multiple meters exist of the same DER type, each meter shall be labeled consecutively (i.e. Utility PV Generation Meter 1, Utility PV Generation Meter 2, etc...)

7.2.2 Company Revenue Metering Requirements

1. The Company will specify the location and arrangement of all equipment required for the revenue metering of the Customer's service and DER facility as well as the monitoring of compliance with all applicable laws, regulations, interconnection agreements, and power purchase agreements. Reference the Company's ESB 750, Section 7 for additional information and requirements. The Company's net metering tariff, **M.D.P.U. 1360**, which describes qualifications for net metering. Where net metering does not apply, the Company's revenue metering will have multiple channels for power delivered and received for power purchase agreements (PPA) or be detented¹⁴ for parallel import connections to prevent reverse billing meter registration. When applicable, credit metering will be installed if arrangements have been made for energy sales to the Company.
2. Customers may be required to provide a telecommunications line to each Company-owned revenue meter location. The telecommunication line would be required only in the event a cellular signal is not present for standard revenue meter reporting. The telephone line shall be capable of direct inward dial without human intervention or interference from other devices such as fax machines, etc. The Company will make the final determination of any Customer proposed alternate telecommunications service for Company-owned revenue metering, if any, for the specific Customer's DER system installation.
3. For fully rated meter installations, the DER source connection shall terminate to the lugs at the bottom of the meter socket. The Utility side connection shall terminate to the lugs at the top of the meter socket.

7.2.2.1 ESS paired with DG

ESS paired with DG projects require a separate meter for ESS and DG metering. Meters for separate DER are installed at the Customer's expense. Metering configurations and arrangements may vary based on specific installations,. See the Company's ESB 750 (<https://www.nationalgridus.com/ProNet/Technical-Resources/Electric-Specifications>) for service and sub-metering installation requirements. For Customers participating in SMART program, the generation metering requirements are described in ([Sample Line Diagrams SMART Program](#)) document in conjunction with ESB 750.

¹⁴ "Detented metering" is measuring and registering power flow in a single direction by either mechanical, or electronic, or programming means in a revenue meter.

7.3 Transformer

7.3.1 Secondary Served Customers

Where the Company provides secondary service, the Company's transformer is an equipment standard for service delivery voltages offered in M.D.P.U. 1316; see Section 3 in **ESB 750**. The maximum transformer size the Company will supply for a new secondary connected DER connection is 300 kVA where the non-DER premises electricity use is 300 kVA or less. Non-standard transformers will not be provided by the Company. The Company will determine when dedicated services and a dedicated transformer are required in order to reduce the impact on other adjacent customers. The need for a dedicated transformer(s) may be determined at any point in the Customer's DER life cycle. If a dedicated transformer(s) is required, the Customer will be advised by the Company in writing. The cost of the transformer(s) will be the responsibility of the Customer according to M.D.P.U. 1316 and as permitted by the **MA SIDG**.

DER facilities proposed on the customer side of an existing Company-owned transformer may require the existing transformer service to be replaced under the following typical conditions, although not all inclusive:

1. DER exceeds the Company's transformer nameplate ratings
2. Interconnection of DER to the customer side of the transformer creates undesirable effects on the Company's EPS.
3. Transformer is a non-standard design no longer provided by the Company's standard (see ESB 750 for standard service voltages) to meet the power quality, safety, and/or reliability to the individual customer, or the EPS.
4. Existing transformer configuration is such that an additional primary side protection scheme is necessary for the DER facility to detect and trip the generation source for faults on the Company's EPS that would require the Customer to have primary service.

7.3.2 Primary and Higher Voltage Served Customers

The Company reserves the right to specify the winding connections for the Customer's interconnection transformer between the Company's delivery point and the Customer's DER facility output terminals as well as whether it is to be grounded or ungrounded. The Customer shall provide their interconnection transformer's specifications and ratings for the Company's review and acceptance in the impact and detailed studies.

7.3.2.1 Effectively Grounded, Four-wire Multi-grounded 3-phase Wye EPS:

To avoid over voltage on the distribution EPS, the Company's policy requires that any DER facility 500 kW and above connected to a four wire distribution feeder to provide an effectively grounded system with respect to the Company's EPS. Refer to Section 7.1.4 for specific grounding requirements.

The Company requires that the IC selects their interface transformer's winding configurations so that the DER system is interconnected effectively grounded. The Customer's DER facility shall be designed such that it cannot connect to the Company EPS without the means of effective grounding in service. In all instances, when the means of effective grounding is out of service or disconnected from the system, the DER site shall be disconnected from the Company EPS.

Aggregate DER below 500 kW in an Customer's facility may be permitted to utilize an ungrounded interconnection (e.g. Primary delta - secondary wye grounded or primary wye grounded – secondary wye grounded transformer with an ungrounded source). The Company reserves the right to require an effectively grounded source

for generation 250 kW and above depending on DER saturation and other conditions on individual distribution EPS feeders.

Effective grounding may be accomplished with the following configurations:

1. A wye-grounded to wye-grounded transformer with a grounded generator source. A neutral grounding reactor between the generator neutral and ground may be required in event the generator's contribution to faults on the Company's EPS results in undesirable fault current values. See section 7.1.5.
2. A wye-grounded connected primary winding with a fully insulated neutral and a delta connected secondary winding. The insulated neutral is to establish provisions for the addition of a grounding reactor or grounding resistor in the event the generator's contribution to faults on the Company's EPS results in undesirable fault current values. See section 7.1.5.
3. A wye-grounded to wye-grounded transformer with an associated grounding transformer.
4. A delta primary winding with a primary side grounding transformer and having any secondary configuration.
5. A wye-grounded primary with wye-ungrounded secondary with a primary side grounding transformer.
6. A wye-ungrounded primary with wye-grounded or wye-ungrounded secondary with a primary side grounding transformer.

7.3.2.2 Not Effectively Grounded, Three-wire 3-phase EPS:

On three-phase Company EPS circuits other than effectively grounded, only the connection of ungrounded primary interface transformers shall be permitted. A delta primary is normally required.

7.4 Manual Generator Disconnecting Means

The Customer's DER facility shall have an electrical load break disconnect switch accessible at all times to the Company to electrically isolate the Company's distribution EPS from the customer's DER system. The Customer shall provide direct 24/7 unencumbered access to the disconnecting switch to allow Company personnel to operate the disconnecting switch and apply protective grounds as needed, without the need to contact the Customer. The Company will make efforts whenever possible to notify the Customer should the DER facility need to be de-activated, however the Company reserves the right to operate the DER facility's disconnect directly in emergency situations in accordance with Section 7 of M.D.P.U. 1320. Refer to section II. B. Operating Requirements of the SIR for additional information.

The Customer shall provide contact information for Customer personnel that can be reached 24/7, should complications arise with access to the Customer's equipment. Should there be any complications with Company access to the DER disconnecting means, the Company reserves the right to disconnect the Customer's service in its entirety via the next upstream Company owned disconnecting means in accordance with Section 7.0 of M.D.P.U. 1320.

The disconnecting means shall have the following characteristics:

1. **Rating:** Disconnecting means shall be rated to interrupt the maximum generator output; meet applicable UL, ANSI, and IEEE standards; and shall be installed to meet the NEC and all applicable local, state, and federal codes.
2. **Arrangement:** The disconnect switch shall be installed to have the line connection (i.e., jaw side) of the switch connected to the utility source. Disconnects with more than one current carrying conductor shall be gang operated. It shall be capable of being grounded on the Company side. The grounding means must be compartmentalized such that the location where the ground is applied is completely barriered from any live parts.
3. **Type:**

1. The type of disconnecting means for all DER is subject to Company approval.
2. For DER systems that are connected directly to the area EPS requiring a manual disconnecting means at the PCC that can be opened for isolation, the device shall be a gang-operated, blade-type switch . Pull-out switches or blocks are not permitted for this application. In accordance with the Company's safety rules and practices, this isolation device must be used to establish a visually open, working clearance boundary when performing maintenance and repair work. The visual open must be observable without opening the equipment.
3. For DER systems connected directly to a Customer's building distribution system downstream of the PCC requiring a manual disconnecting means for isolation of the DER, the disconnecting means may be a draw out circuit breaker, disconnect, or comparable device mutually agreed upon by the Company and the Customer. In accordance with the Company's safety rules and practices, this isolation device must be used to establish a visually open, working clearance boundary when performing maintenance and repair work. For installations above 600 V, the visual open of all three phases shall be capable of being observed without opening the equipment. Site-specific technical requirements will be considered by the Company if permitted to grant draw-out breakers with the provision for padlocking at the draw-out position, above 600 V or with a full load output of greater than 960 A, that are proposed to meet these isolation requirements. If the Company grants such use, the Customer will be required, upon the Company's request, to provide qualified operating personnel to open the draw-out circuit breaker and ensure isolation of the DER system, with such operation to be witnessed by the Company followed immediately by the Company locking the device to prevent re-energization. In an emergency or outage situation, where there is no access to the draw-out breaker or no qualified personnel, the Company may disconnect the electric service to the premise to isolate the DER system.
4. Location:
 1. The location of the disconnecting means shall comply with Company standards for working clearances, access road construction, vegetation management, and other similar requirements to ensure adequate access for Company personnel and equipment.
 2. The location for the disconnecting means for all DER projects is subject to Company approval on a case by case basis and shall comply with Company standards for working clearances, access road construction, vegetation management, and other similar requirements to ensure adequate access for Company operating personnel and equipment.
5. Access and Locks:
 1. The disconnecting means must be readily accessible at all times to the Company to electrically isolate the Company's Distribution EPS from the Customer's generator facilities. In all instances, the disconnecting means shall have provisions to be locked in the open position with space for Company and Customer padlocks.
 2. Should the disconnecting means be located behind the Customer's locked gate, double locking is required, where both the Company's and Customer's locks would be employed.
6. Identification: All required disconnecting means shall be identified by a permanent sign as required by the NEC and the ESB 750.

Exception:

In accordance with the **MA SIDG** and the Company's electric service requirements of ESB 750, inverter-based systems 25 kW and below are not required to have a separate manual disconnecting means if the unit has a disconnecting means integrated into the design and meets the requirements of the National Electrical Code (NEC).

For systems 25 kW and below, a disconnecting or isolation means¹⁵ shall be required to be located between the Company meter and the DER device to allow for Company testing of the meter socket prior to meter installation. This device may be located based on customer preference, although where this device is not accessible to the Company, this may cause delay with associated meter installation and testing.

7.5 Generator Interrupting Device Requirements

7.5.1 General

1. For any aggregate generation connected to a common feeder that is 500 kW and greater, an interconnection interrupting device such as a circuit breaker shall be installed at the Customer's site. The 500 kW criteria is intended to encompass individual sites that are comprised of multiple smaller generators, totaling 500 kW or greater. It is also intended to encompass generation located at multiple sites that total 500 kW. Due to the unique circumstances of each individual installation, the Company reserves the right to require an interrupting device if necessary. As such, interrupting devices may be required for projects below 500 kW, if the project warrants the installation. The Company may elect to waive this requirement if all Company protective and interrupting requirements are met by a Company device at the facility.
2. The generator interrupting device shall be designed to ensure the interrupting of the DER system, and its effective grounding source upon loss of interrupting device supply power, or upon loss of local power supply source.
3. When a local power supply source is utilized, generator interconnection interrupting devices shall have DC trip coils and tripping energy.
4. For primary wye grounded – secondary delta, and for primary delta interconnection transformers, the interrupting device shall be installed on the high voltage side. If there is more than one interconnection transformer, this requirement applies to each one individually. The interconnection interrupting device shall be capable of interrupting the current produced when the DER facility is connected out of phase with the Company's EPS.
5. The interrupting device shall be located upstream (closer to the Company's source) of the generation and any grounding transformer(s), so that it is capable of disconnecting the fault current contributions of the generation and grounding transformer.

7.5.2 Local Power Supply Requirements

When a continuous local power supply is proposed to comply with the Company's protection element operational requirements to safely remove the generation from the EPS, the following conditions shall be met:

¹⁵For all customers including behind-the-meter DER installations, the customer's main service or parallel power production disconnect is in a position where isolation has been available. This isolation has typically been the main service overcurrent protection device. With the inclusion of sub-metering installations, the main service OCP is no longer positioned between the circuit path between the sub-meter and the connected DER device. Therefore, an isolation point to allow for testing is required. The Company recommends locating this disconnecting device outside, adjacent to the meter socket to allow for the most flexibility for meter installation and future change-outs.

1. Failure of an uninterruptible power supply (UPS) rectifier shall not inhibit relay power supply and operation from the local power supply.
2. A fail-safe alarm contact shall be incorporated into the control trip scheme of the interrupting device for loss of local power supply charge source.
3. The local power supply shall be sized to ensure successful operation of generator interrupting device upon loss of charge source. This supply shall be capable of providing all power requirements to initiate and complete the entire operating process of tripping the interconnection interrupting device.
4. The local power supply system shall be hard-wired and permanently installed. Portable cord-and-plug devices are prohibited.
5. System design calculations in accordance with IEEE standards and other industry standards as applicable shall be provided by the Customer for supply voltage, capacity specifications, and charging system provisions and are subject to the Company's review and acceptance.
6. Control circuits associated with protective relays shall be DC powered from a battery and battery charger system. The battery shall be the sole source of tripping energy. Solid state relays shall be self-powered or DC powered from a battery and battery charger system.
7. If the DER facility uses a non-latching interconnection contactor, AC powered relaying may be permitted provided the relay as well as its method of application are fail-safe, meaning that if the relay fails or if the voltage and/or frequency of its AC power source deviate from the relay's design requirements for power, the relay or a separate fail-safe power monitoring relay will immediately trip the generator by opening the coil circuit of the interconnection contactor after a maximum 2 second time delay.

7.6 Protection and Protective Equipment Requirements

The Interconnection Customer is solely responsible for the protection of their DER and premise equipment, including any customer equipment required by the Company to interconnect to the area EPS. The Interconnection Customer is also required to provide electrical equipment and relays with ranges and rating that will allow proper DER and premise relay system coordination with Company protection systems. Coordination margins and parameters will be determined by the Company.

The protection system shall be designed with interlocks and protective functions to ensure that there is proper voltage, frequency and phase angle conditions between the Company's EPS before the DER system is permitted to parallel. The Customer is responsible for voltage excursion detection and the detection of three-phase, line-to-line, and line-to-ground faults on the Company's EPS as well as faults on the Customer's system that cause overcurrent conditions on the Company's EPS.

All DER facilities shall meet performance requirements set forth by Section 4.2.3 in the MA SIDG. DER types of interconnection are categorized as either Group 1 "Facilities Qualified for Simplified Interconnection" or Group 2 "All Facilities Not Qualified for Simplified Interconnection" according to the **MA SIDG**. The Under Frequency relays for the all DER facilities shall not trip at frequencies higher than the curve provided for the "Eastern Interconnection Generator Tripping" in Figure 1 of the PRC-006-NPCC-1 Automatic Under frequency Load Shedding criteria specified in the **MA SIDG**. The Company may specify values within the allowable ranges of IEEE 1547 subject to the limitations on voltage and frequency trip settings specified by the regional reliability coordinator that consider bulk power system impacts of affected aggregate DER capacity. Where Regional ISO voltage and frequency requirements apply, the Customer shall refer to the Company's ESB 756

Appendix A for specific requirements related to North American Electric Reliability Corporation (NERC) Protection and Control (PRC) standards.¹⁶

The Customer's interconnection system shall have the capability to withstand voltage and current surges in accordance with the environments defined in the latest IEEE Standard C62.41.2 or IEEE Standard C37.90.1 as applicable.

For the purpose of evaluating fault current, short circuit protection, and protective relay settings, current values are based on the full Volt-Ampere (VA) nameplate rating of the equipment, which may be greater than the kW rating of the equipment. For ESS, all protection reviews, regardless of any on-site operational limitations, are performed at the sum of the nameplate ratings of the ESS and any paired DG since fault currents are related to the full kVA nameplate ratings of the inverter(s) and/or generators used.

7.6.1 Type Tested (Certified) Equipment

Protective equipment that has been type tested and recognized under UL Standard 1741 by the **MA SIDG** for Group 1 DER facilities will be permitted. The Customer shall follow the testing requirements as outlined in the MA SIDG. **Exhibit 7** attached is a guide for the Company's witness for verifying a type tested net-metered DER installation's operational compliance.

7.6.2 Non-Type Tested Equipment

Protective equipment that has not been type tested per the MA SIDG and considered as Group 2 DER facilities will be permitted with the implementation of utility grade protective devices acceptable to the Company. The use of utility grade relays¹⁷ is subject to prior Company review and acceptance per section 7.6.3.2.

7.6.3 Number of Relays Required

For all DER facilities 500 kW and greater, redundant relaying is required for the detection of Area EPS faults & disturbances. Relays are considered redundant only when two utility grade relays with identical protective functions are provided.

Where relay performance may affect the operation of the Company's EPS at service voltages less than 15 kV, a single utility grade microprocessor-based relay along with a Company approved scheme, where relay failure automatically trips the associated breaker(s), may be acceptable. The utility grade relay failure alarm shall be wired to trip and block close the Company-designated generator interrupting device. Auxiliary relays, where used, shall be fail safe and utility grade. If two utility grade relays are used to provide redundancy, whether relay failure or being out of service, if neither relay can perform the intended protection functions the protection scheme shall trip and block close the interrupting device.

7.6.3.1 Certified Inverter-based Energy Resource Protection Requirements

IEEE 1547 compliant and UL-1741 certified¹⁸ inverters shall be equipped with an internal active anti-islanding scheme, under voltage (27), over voltage (59), under frequency (81U) and over frequency (81O) relays. Inverter based generators shall be in compliance with the latest version of IEEE 1547. The Customer shall provide the

¹⁶ See <https://www.nerc.com/pa/Stand/Pages/ReliabilityStandards.aspx> and <https://www.nerc.com/pa/stand/Pages/ReliabilityStandardsUnitedStates.aspx?jurisdiction=United%20States>.

¹⁷ See definition of "utility grade" for protective device equipment in Section 4.

¹⁸ See definition for "certified" in Section 4.

voltage and frequency ride through capabilities as specified in IEEE 1547 Category II in any inverters installed as part of a DER facility proposed to interconnect to the Company's EPS. The voltage regulation capabilities in the device shall be turned OFF unless otherwise required by the Company. See section 7.8 for further inverter function requirements.

7.6.3.1.1 Certified Inverter-based Energy Resources below 500 kW

If the inverter(s) are IEEE 1547 compliant and UL-1741 listed in the configuration proposed for interconnection, the internal relays are considered as the only required protection and an additional utility grade relay is not required to be installed. At the Company's sole discretion, the Company reserves the right to require a utility grade relay for certified systems above 250 kW with, at minimum, functions 27, 59, 81U/O enabled.

7.6.3.1.2 Certified Inverter-based Energy Resources Equal or above 500 kW

For inverters that are IEEE 1547 compliant and UL-1741 listed in the configuration proposed for the interconnection, inverter internal relay functions are considered as primary protection. The Company requires one additional utility grade relay to be installed as secondary to the utility grade protection for inverter-based DER equal or greater than 500 kW. The 27, 59, 81U/O and 51N or 51G elements shall be activated in the utility grade protection relay. On circuits where generation is permitted to connect as an ungrounded source, a 59N relay function is required to detect ground faults on the utility. Where Company-required functions are not redundant, such as overcurrent or 59N functions, refer to section 7.6.3 for fail-safe tripping requirements.

7.6.3.2 Non-Certified Energy Resource Protection Requirements

Where Company-required functions are not redundant, such as overcurrent or 59N functions, refer to section 7.6.3 for fail-safe tripping requirements.

7.6.3.2.1 Energy Resources below 500 kW

For any non-certified generator less than 500 kW one utility grade relay is required to be installed. 27, 59, and 81 U/O at minimum shall be active in the utility grade relay. For all systems 250 kW or larger, the Company reserves the right to require redundant utility grade relaying.

7.6.3.2.2 Energy Resources 500 kW and greater

For any non-certified generator 500 kW and greater, two utility grade relays are required to be installed with 27, 59, 81 U/O, and overcurrent elements for both phase and ground. On circuits where generation is permitted to connect as an ungrounded source, a 59N relay function is required to detect ground faults on the area EPS.

7.6.4 Instrument Transformers for Protective Relays

7.6.4.1 Current Transformers (CT)

CT ratios and accuracy classes shall be chosen such that secondary current is less than 5 amperes normal operation, 100 amperes under maximum fault condition and transformation errors are consistent with Company practices. For the primary wye grounded – secondary delta installations, the CTs shall be installed on the high side. If the interconnection transformer is primary wye grounded – secondary wye grounded, the CTs can be installed on either high or low side, provided the CTs sense the current contribution to Company EPS faults from ground sources installed on the facility. CT accuracy and burden calculations shall be provided for review by the Company.

7.6.4.2 Voltage Transformers (VT) and Connections

Voltage sensing is required on all three phases on the utility side of the interrupting device. VTs for voltage sensing shall be configured wye-grounded (Yg-Yg). Voltage measurements shall have no more than 2% error under the expected ambient temperature range (-10°C (14°F) to +45°C (113°F)) and no higher than 4% error under

all operating temperatures (-40°C (-40°F) to +65°C (149°F)). If the secondary voltages can be used to detect voltage depressions for faults that occur on the Utility EPS, and the secondary voltage is within the relay's acceptable operating range, VTs may not be required. The use of Yg-Broken Delta VTs will be considered by the Company on a case-by-case basis.

7.6.5 Protective Relay and Trip Circuit Hard-Wire Requirements

Unless authorized otherwise by the Company, protective relays shall be hardwired to the device they are tripping. Further, interposing computer-based or programmable logic controllers, auxiliary modules, or the like are not permitted in the trip control scheme between the relay and the device being tripped. Trip circuits shall not be fused.

The use of interposing relays is subject to approval by the Company. Interposing relays, if proposed, shall be utility grade, and the tripping scheme shall be fail-safe.

Meter selector switches shall not be connected into the secondary circuits of current transformers used with protective relays specified by the Company.

Generator protective relays shall be located no greater than 30 feet from the device in which they control.

7.6.6 Protective Relay Test Switch Requirements

Microprocessor and non-draw out relays, including relay function 86 shall have ABB FT-1, or equivalent, test switches isolating all inputs and outputs of the relay. All test switches shall be labeled for the associated relay functions.

- **AC Inputs:** Each relay shall have its own AC test switch. DC inputs or outputs are not permitted on AC test switches.
- **DC Inputs and Outputs:**
 - For relays designated by the Company as necessary to protect the Company's Distribution EPS, it is required that each individual relay have its own DC test switch that isolates the positive and negative DC for each input and output.
 - For relays required to protect the Customer's equipment, it is required that each relay have its own DC test switch for inputs and outputs. For ease of maintenance testing and troubleshooting, it is required to isolate the positive and negative DC of the input and output.
- Groups of relays that protect the same piece of equipment, such as a transformer or a feeder, may share a DC test switch under the following conditions:
 - The individual blades of the test switch shall be grouped by relay.
 - A permanent label shall be affixed to the relay panel identifying the use of each blade.

Exception: Where the relay inputs are supplied by a control cable (such as a some recloser installations) and the relay test set uses a control cable that inputs to the same port in the recloser control enclosure, test switches may not be required.

7.6.7 Voltage Relay Devices

Voltage relays shall be frequency compensated to provide a uniform response in the range of 40 to 70 Hz, and meet IEEE 1547 requirements including capability for under/over voltage ride through. See Table 7.6.11.1-1 below for default voltage relay settings.

7.6.8 Frequency Relay Devices

Over and Under Frequency relays shall meet IEEE 1547 requirements including capability for under frequency ride through. The under-frequency trip setting shall not be higher than 58.9 Hz, as to not conflict with the under-frequency load shedding schemes on the Company's EPS. For adjustable under frequency, the chosen setting shall not fall

within the prohibited region of NERC PRC-006-219. See Table 7.6.11.1-1 below for default frequency relay settings.

7.6.9 Synchronizing Devices

The Customer shall designate one or more synchronizing devices that employ a synchronizing protection element (25) such as motorized breakers, contactor/breaker combinations, or a fused contactor (if mutually agreeable) to be used to connect the DER facility's generator to the Company's EPS. This synchronizing device could be a device other than the interconnection interrupting device and shall be utility grade. The synchronizing device shall be capable of interrupting the current produced when the DER facility is connected out of phase with the Company's EPS. Synchronism check relay functions are required at all breakers through which the generation will be synchronized with the utility source. This includes any breakers where any part of the Customer's DER facility will island and then synchronize back to the Company's EPS.

7.6.10 Overcurrent Relay Devices

Overcurrent protection is required to detect faults on the Company's EPS, as well as faults on the Customer system that cause overcurrent conditions on the Company EPS. Overcurrent elements are required for both phase and ground in accordance with 7.6.3. Where a voltage controlled phase (51C) element is required, relays shall utilize voltage sensing via the Yg-Yg VTs specified in section 7.6.4.2.

7.6.11 Utility Grade Relay and Protective Device Settings and Verification

7.6.11.1 Default Voltage and Frequency Set points for all types of Energy Resources

Unless otherwise specified by the Company, the default settings for voltage and frequency trip elements are required to have setting ranges according to the following table 7.6.11.1-1 and the final time delay settings shall be approved by the Company:

Table 7.6.11.1-1 Utility Grade Relay and Parallel Generation Default Voltage & Frequency Set Points

DEVICE	PICKUP RANGE (Defaults set points in bold)	DEFAULT CLEARING TIME (sec)
Under Frequency (81U)	\leq 56.5 Hz	0.16
Under Frequency (81U)	$<$ 58.5 Hz	300
Over Frequency (81O)	61.2 Hz \leq f $<$ 62.0Hz	300
Over Frequency (81O)	\geq 62.0 Hz	0.16
Under Voltage (27)	\leq 50% of Nominal	1.1
Under Voltage (27)	50% $<$ V \leq 88% of Nominal	2
Over Voltage (59)	110% \leq V $<$ 120% of Nominal	2
Over Voltage (59)	\geq 120% of Nominal	0.16

Settings other than the default, within the settings ranges in IEEE 1547, may be acceptable on a case-by-case basis and are subject to review and approval by the Company. DER facilities with Direct Transfer Trip installed may be required to have wider than the default settings to comply with ride through requirements.

Note that consistent with IEEE 1547, the pickups are exact set points and the time delays are maximum total clearing times (including relay and device interruption time). The above default voltage and frequency trip settings are consistent with the National Grid Source Requirements Document ([National Grid SRD](#)) for DER.

7.6.11.2 Synchronism Check Setting Requirements for all types of Generation

19 See <https://www.nerc.com/pa/Stand/Reliability%20Standards/PRC-006-2.pdf>.

Unless otherwise specified by the Company, the default settings for utility-grade synchronism check elements are required to have settings according to the following table 7.6.11.2-1 and the final settings shall be approved by the Company:

Table 7.6.11.2-1 Relay Settings to Parallel with the Company EPS

Generator Size (kVA)	Max. Frequency Difference (Δf , Hz)	Max. Voltage Difference (ΔV , %)	Max. Phase Angle Difference ($\Delta \Phi$, degrees)
0-500	0.3	10	20
>500 – 1,500	0.2	5	15
>1,500 – 10,000	0.1	3	10

7.6.11.3 Company-designated Relays and Customer Settings

1. The Company will review the Customer's settings and their calibration and test results of those relays that the Company designates as being required to satisfy the Company protection practices. In addition, the Company may require the relaying summary and logic diagrams depending on the complexity of the installation.
2. Any relay setting specified by the Company shall not be changed or modified at any time without the written consent of the Company.
3. The Customer shall be responsible to specify the settings, calibrate, test, and maintain the balance of their equipment.

7.6.11.4 Company Verification of Relay Testing

Prior to the Witness Test, the Company requires a letter from the Customer stipulating that all Company-designated protective devices have:

- control wiring verified against the accepted design drawings, and
- the calibration test performed satisfactorily according to the relay setting document of the accepted design.

7.6.12 Unintentional Islanding Protection for DER

The Customer's DER system shall not energize a de-energized Company circuit; therefore, anti-islanding protection is required for parallel generation on the Company's distribution EPS. If the Company determines that an anti-islanding protection scheme is required to mitigate the risk of a formation of an island in addition to the generator facility's own islanding detection scheme then the Company will require direct transfer trip (DTT). The Customer may propose alternative methods of anti-islanding protection of their own generation facility, although it is the Customer's responsibility to demonstrate comprehensively the validity of such methods and the Company reserves the right to make the final determination as to which anti-islanding protection method is suitable to meet the EPS safety and reliability requirements.

Note: A Customer wishing to use a generation system as a stand-by or emergency generator shall submit details regarding an interlocking scheme or transfer switch to prevent the energization of a de-energized Company circuit that complies with National Grid ESB 750, Section 11.

7.6.12.1 General

1. The Company may reclose at any distribution EPS segment at any time without checking for de-energized segments as normal system operations to maintain service reliability. It is important to the DER operator to be aware of this possibility as it is the responsibility of the DER operator to trip off within 2 seconds in the event the EPS utility source is not present.
2. During DER impact evaluation, when a DER on the circuit causes the Company's system protection to be unable to trip for end of line faults, appropriate measures

- will be taken to correct this protection gap. The Company's device setting adjustments, additional protection devices, and/or customer impedance grounding may be required.
3. The requirements outlined below in regards to unintentional islanding mitigation risks are not applicable for DER proposed to be interconnected to a Company secondary network system. The Company's network systems are not designed for and cannot accept back feed.
 4. Utility interactive inverters evaluated under these requirements shall not actively regulate frequency and/or voltage or provide Var support functions. Any inverter type generation established as frequency and/or voltage regulating or Var supportive will be reviewed under section 7.6.12.4 requirements.
 5. DER threshold values shall be analyzed in aggregate where multiple DER projects are supplied from a single point of connection to the EPS. Individual DER projects on sub-divided or adjacent parcels may be evaluated based upon total aggregate nameplate ratings as an equivalent single point connection to the EPS.
 6. For cases where the line section aggregated DER is $\leq 33\%$ of minimum load regardless of DER type mix and is connected to < 35 kV distribution EPS no additional requirements identified below shall be required.
 7. For DER equipped with DTT, those DER facilities will not be factored into the 10 and 25% ratio screens identified in this bulletin.
 8. Where used within this document, reclose blocking is a voltage supervised reclose permissive feature required at any mid-line automated interrupting device identified through the steps outlined. Where this feature is required, each mid-line device is also required to be SCADA equipped through National Grid's distribution EMS cellular network.
 9. A complete distribution feeder may contain multiple line sections. Depending on the aggregate DER size to load ratio, multiple line sections may require review and be screened accordingly per the steps outlined.
 10. Each screen shall be repeated for each line section applicable to the proposed DER. Where DTT or reclose blocking is required based on the screens, it shall be applied at the sectionalizing device for that line section.

7.6.12.2 Islanding risk mitigation methods required

Special conditions outlined within this section are required at minimum, regardless of the screening outcomes applicable in the following sections.

1. Cases where the Company's PCC recloser is required regardless of DER type:
 - a. DER > 300 kW and DER $> 33\%$ minimum load and is connected to < 5 kV EPS.
 - b. DER connected to > 15 kV and < 35 kV EPS where DER $> 50\%$ onsite minimum host load.
2. Cases where additional EPS protection schemes, including but not limited to transfer tripping, may be required regardless of DER type:²⁰
 - a. If line faults (phase and ground where applicable) cannot be cleared by DER protective device or the Company's PCC recloser.²¹
 - b. Unique arrangements not explicitly defined within this document at the Company's discretion.

²⁰ While the intent of this unintentional islanding protection policy is to encourage DER installations while minimizing inhibitive impacts to the DER installation, the Company reserves the right and flexibility to enforce protective measures deemed required for the safety and reliability of the EPS.

²¹ Customers should be aware that >15 kV class circuits typically involve more complex protection schemes, which can be more likely to require DTT due to inability to see and trip faults in an acceptable time frame, in addition to operational issues that may be present at these voltage classes (23kV and 34.5kV).

- c. If the DER cannot be tripped off with utility-owned devices when automated sectionalizing schemes will operate.
 - d. DER connected to > 35 kV EPS where DER > 50% onsite minimum load and the connecting line is radially supplied.
3. The Company shall be provided with access rights, whether easement or fee-owned right-of-way, of the Company's facilities on the Customer's property for the PCC recloser installation serving their DER facility. See Exhibit 6 for a typical one-line configuration of a PCC recloser primary metered overhead service.

7.6.12.3 Certified DER²²

1. All inverters shall have an 88% voltage trip within 2 seconds to be considered in this section.
2. Proposed DER rated ≤ 50 kW
 - a. No requirements.
3. Proposed DER rated > 50 kW and < 1000 kW
 - a. Line section aggregated non-certified DER is $\leq 10\%$ of mix.
 - i. No additional requirements.
 - b. Line section aggregated non-certified DER is > 10% and $\leq 25\%$ of aggregate DER.
 - i. Sandia screening²³ may be applicable depending on inverter models on segment.
 - ii. Company-owned PCC recloser and reclose blocking on line segment sectionalizing device required if Sandia screens not passed.
 1. Detailed risk of islanding (ROI) study may be performed at the Customer's request. If results of the detailed study show no significant risk of islanding for a period greater than 2 seconds, then the recloser and reclose blocking is waived.
 - c. Line section aggregated non-certified DER is > 25% of all DER.
 - i. Company-owned PCC recloser required
 - ii. Reclose blocking required on line segment sectionalizing device²⁴
 1. Detailed ROI study may be performed at the Customer's request. If results of the detailed study show no significant risk of islanding for a period greater than 2 seconds, then reclose blocking is waived. Company-owned PCC recloser is waived for aggregate DER $\leq 67\%$ of line load to generation ratio or < 500 kW.
4. Proposed DER rated DER ≥ 1000 kW
 - a. Company-owned PCC Recloser required.
 - b. Reclose blocking required on line segment sectionalizing device if line segment aggregate DER > 50% of minimum load.

7.6.12.4 Non-certified & voltage or frequency regulating inverters, induction & synchronous machines

²² Inverter firmware derating is not acceptable for reduction of system size to satisfy thresholds within this section.

²³ The Sandia screens (<http://energy.sandia.gov/wp-content/gallery/uploads/SAND2012-1365-v2.pdf>) are valid only for those certified inverters that have been confirmed, in writing from the manufacturer, to meet the definition of the Sandia Frequency Shift (SFS), or Sandia Voltage Shift (SVS) as positive feedback based methods according to the report or for inverters using impedance detection with positive feedback. SFS and SVS both rely on positive feedback to work.

Positive feedback – detecting a deviation in grid parameters and acting to try to make that deviation from nominal worse. Where acting to try to make that deviation worse, the perturbations must push harder as the deviations from nominal increase. The algorithm must be able to push bi-directionally in order to be considered for this screen.

²⁴ Where feasible, installing a PCC recloser in front of the non-certified DER may reduce or eliminate any further requirements to the subject applicant DER.

1. Require ANSI C37.90 utility-grade protective relay with IEEE 1547 voltage and frequency tripping and restoration functions.
2. Total aggregate line section DER > 33% minimum load
 - a. DTT required.

7.7 Monitoring and Control (M&C) at DER Facility

DER ranging from 250 kW in capacity and up on radial distribution systems may require supervisory control and data acquisition (SCADA) communication for visibility to the Company's energy management system (EMS) and to incorporate the ability for the Company's system operators via EMS to remote trip the generation, or DER facility, from the Company's EPS. This visibility is essential in maintaining daily system operability and the flexibility to transfer loads and feeder segments to allow for system upgrades, repairs, seasonal loading transfers, and other normal distribution system management functions that may require a SCADA remote terminal unit (RTU) or a PCC Recloser at a DER facility.;

7.7.1 For Independent Power Producer (IPP) – “Utility Connected Stand Alone” projects (DER with no load)

1. The Company generally does not require any RTU system for IPP generators, regardless of the size or voltage class.
2. For all standalone DER \geq 1MW in facility size, a Company-owned PCC recloser is required for monitoring & control.
3. Where available, the Company will utilize the Company-owned PCC Recloser serving the DER installation to obtain Company's operational polling data.
4. The Interconnecting Customer (IC) is advised to communicate with Independent System Operator (ISO) -New England for any telemetry requirement as ISO-NE may require real-time monitoring between ISO-NE EMS and the DER site. The IC shall refer to the ISO-NE website and ISO-NE customer service help desk for details.
5. The Company reserves the right to require the IPP customer to install a RTU at their facility for any special circumstances. One situation where an EMS-RTU may be required is where there is Distribution EPS feeder selectivity operation.

7.7.2 For Non IPP - “Behind the meter” projects (DER's with customer Load)

1. For Non IPP projects, the Company will require the Interconnecting Customer (IC) to install RTU at their facility based on the Company's delivery voltage level and the DER size. RTUs will be required for “behind the meter” DER installations for the feeder voltage class values provided in the table below.

Table 7.7.2-1: RTU Requirements by Facility Size

Delivery Voltage Class	Non IPP Generating Capacity
5kV or below.	500 kW or greater
greater than 5kV but less than 15kV	1 MW or greater
>15kV	1.8 MW or greater

2. EMS-RTU installations may be required for DER applications not covered by the conditions above as determined by the Company on a case-by-case basis. One situation where an EMS-RTU may be required is where there is Distribution EPS feeder selectivity operation.
3. The control portion would only involve the remote trip and block closing of the Customer's interrupting device(s) designated by the Company. The block close function will be performed by control circuitry and is subject to review by the Company for acceptance.
4. The required inputs from the RTU to the Company's EMS shall be as follows:
 - Status of main or interconnect breaker at the point of common coupling (PCC)

- Status of individual generator breakers
- Control input for the “designated generator interrupting device” for trip, block close & permit close functionality
- Three phase line current for each generator
- Three phase line current at the PCC with the Company (when there is multiple generator breakers)
- Three phase line-to-line voltage for each generator
- Three phase line-to-line voltage at the PCC with the Company(when there is multiple generator breakers)
- Output kW for each unit (+ delivered to the Company, - received)
- Output kVAR for each unit (+ delivered to the Company, - received)
- Total MW (+ delivered by generator, - received by generator) at the PCC
- Total MVAR (+ delivered by generator, - received by generator) at the PCC

Exceptions to the above list may be considered by the Company on a case-by-case basis

Note: The Company will provide an EMS-RTU point list for inputs required at the DER system.

5. When a Company EMS-RTU is specified for a parallel generation project, the Company will determine the requirements for equipment, installation, and communications media in the interconnection study for the DER system. The Customer will be responsible for all initial and recurring costs associated with communications for their RTU.
6. The Interconnecting Customer (IC) is advised to communicate with Independent System Operator (ISO) -New England for any telemetry requirement as ISO-NE may require real-time monitoring between ISO-NE EMS and the DER site. The IC shall refer to the ISO-NE website and ISO-NE customer service help desk for details.

7.8 Voltage and Frequency Ride Through and Control Requirements

7.8.1 Voltage and Frequency Ride Through

Inverter-based DER shall meet the requirements of IEEE 1547 Category II and the requirements of the [National Grid SRD](#). See section 7.6.11 for corresponding voltage and frequency default trip settings in accordance with the [National Grid SRD](#).

7.8.2 Voltage and Frequency Control

1. All generators shall be in compliance with the latest revision of IEEE 1547. Field adjustable settings shall not be changed without express written consent of the Company.
2. The voltage and frequency capabilities permitted in IEEE 1547 shall be disabled by default in accordance with Table 7.8.2.2-1 unless otherwise approved by the Company.

Table 7.8.2.2-1: Default Mode Settings for Inverter-based Utility Interactive DER

Function	Default Activation State
SPF, Specified Power Factor	OFF ²⁵
Q(V), Volt-Var Function with Watt or Var Priority	OFF
SS, Soft-Start Ramp Rate	ON Default value: 2% of maximum current output per second
FW, Freq-Watt Function OFF	OFF

²⁵ OFF and operating at unity PF. Or set to ON with unity PF.

The above mode settings are in accordance with the [National Grid SRD](#). If a device does not have the above mode settings and is not within the scope of the [National Grid SRD](#), the device shall operate in unity power factor mode with any available grid support functions disabled.

7.8.3 Return to Service

The DER shall not connect or return to service following a trip (including any ground fault current sources) until detecting 5 minutes of healthy utility voltage and frequency. Detection and return to service function shall be performed by utility grade relay where utility grade relay is required. "Healthy Utility Voltage and Frequency" is defined by Table 7.8.3-1, in accordance with the Enter Service Criteria in IEEE Std.1547-2018 section 4.10:

Table 7.8.3-1: Return to Service Parameters for DER

Utility Voltage Parameter	Default Value
Minimum Return to Service Voltage:	0.95 per unit of nominal voltage
Maximum Return to Service Voltage:	1.05 per unit of nominal voltage
Minimum Return to Service Frequency:	59.5 Hz
Maximum Return to Service Frequency:	60.5 Hz

8.0 Testing and Commissioning

1. The Company reserves the right to witness the Customer's functional testing of the required devices, i.e., trip tests.
2. All Company-designated relay functions and all synchronizing elements will be witness-tested/verified by the Company's personnel prior to energization.
3. A letter, written by the Customer or their assigned agent, indicating the protection and control scheme has been functionally tested in accordance with the Customer's submitted design as accepted by the Company, shall be completed prior to the Company's witness testing.
4. The Customer shall submit a testing and commissioning plan (TCP) to the Company for review at least 20 business days prior to the scheduled witness test. If needed, consult the Company for guidance on preparing a TCP. This activity will normally be performed as specified by Section 4.2.4 in the **MA SIDG**.
5. All required equipment test reports shall be submitted per ESB 751 prior to final TCP acceptance.
6. The TCP shall be finalized as accepted by the Company no later than five (5) business days prior to functional testing of the Company-designated protective devices.

9.0 Operating

1. The Customer's DER system shall maintain a power factor at the PCC in accordance with the MA SIDG between 0.90 leading or lagging (VAR or voltage support can also be considered within machine ratings) unless more strict requirements apply according to the Company's Impact or Detailed Study. Corrective equipment may be required and, if so, it will be at the Customer's expense; refer to ESB 750. It is the Company's expectation that the Customer will strive to maintain a power factor at their service point that does not adversely affect the power quality (PQ) of the Company's EPS; see ESB 750.
2. The Company requires a Sequence of Operations (SOO) from the Customer. The Company also requires an operating description from the Interconnection Customer for normal, alternate, and emergency (if proposed) operations, if the Customer desires to operate in these modes and in the event of any changes to the existing procedures.
3. The Customer is responsible for performing all operating functions associated with their equipment and for maintaining all equipment under their ownership. The Customer shall arrange to have trained personnel available for the proper and safe operation of their equipment.
4. The Customer shall follow the Company's specified switching protocol upon commissioning, synchronizing, and return-to-service situations with the Company's distribution system operator; see ESB 755 for more information on Customer operating and maintenance responsibilities.
5. The Customer's service and backup service requirements from the Company's system shall be requested using the prescribed forms in the Company's electricity tariff, M.D.P.U. 1316.

6. Where the Company is requested to supply demand pulse information (either analog or digital), its use is not intended for generator dispatch or control.
7. Should the Customer Facility experience unexpected tripping of their interrupting device, the Customer shall first perform their own extensive analysis of all possible causes for trips of their own system before attempting to resolve those issues through the Company.
8. The Customer shall provide relay event records upon request following a system disturbance.

10.0 Power Quality Monitoring

10.1 Power Quality Compliance Verification

If during the study a DER interconnection project is identified as having the potential to cause power quality (PQ) effects on the EPS, then PQ monitoring shall be installed by the Company or Company-accepted third party PQ testing company to verify the Customer is maintaining its power quality with and without generation. Third party PQ test methods and results may be submitted to the Company for review and acceptance. These verification tests shall include, at a minimum, the following in accordance with the Company's electricity tariff, M.D.P.U. 1316 and the limits and cost responsibilities specified in the MA SIDG:

- Check service point voltage for any discernible voltage fluctuation.
- Check service point frequency for any discernible frequency fluctuation.
- Check PCC power factor to ensure it is no less than 90% (leading or lagging).
- Check service point harmonic distortion to ensure limits specified in ESB 750 and the MA SIDG as applicable, are maintained. Current harmonic distortion shall not adversely affect voltage harmonic distortion, the Company Distribution EPS, or service to other customers.

10.2 Power Quality Disturbance and Mitigation

1. If disturbances on the EPS and/or to other customers are suspected to originate from a Customer with DER, PQ monitoring shall be installed to verify the Customer is maintaining their power quality in accordance with the Company's ESB 750 and the MA SIDG.
2. If it is determined that system modifications or changes are needed in order to mitigate the disturbance issue, the cost of such modifications or changes shall be borne by the Interconnection Customer.
3. If any power quality concerns as a result of the Customer's DER installation cannot be immediately corrected, the Customer **will not be permitted** to continue generation until such concerns are resolved to the Company's satisfaction.

10.3 Transient Overvoltage/Load Rejection Overvoltage (LROV)

The DER facility shall limit its cumulative instantaneous overvoltage according to Figure 3 of IEEE Std.1547-2018 section 7.4.2.

Most inverters have a 'self-protective overvoltage' setting in the inverters that, if enabled, is capable of tripping for no higher than 1.4pu voltage in 1ms or less clearing time. This set point is one acceptable means to meet the requirements if a letter from the inverter manufacturer is provided to the Company stating that this setting (or tighter) is enabled in the inverters to be installed on the site, and the inverter voltage response adheres to the curve in IEEE 1547. The Customer shall provide a letter from the inverter manufacturer or a National Recognized Testing Laboratory (NRTL) confirming that the requirements from the standard are met. The letter shall be on the manufacturer or NRTL letterhead and include the firmware version and serial numbers of each inverter

for the installation. Test data and/or standards certification supporting these statements may also be required at the discretion of the Company.

11.0 Facility Audit

The Company reserves the right to periodically audit the Customer's generation equipment installation and service connection for compliance with the Company's requirements.

12.0 Disconnection by the Company (Isolation)

Pursuant to Section 7 in the **MA SIDG**, the Company reserves the right to have the Customer remove their generation from the Company EPS at any time upon the Company's request. Normally, such requests result from the need to facilitate maintenance, test, or repair of Company facilities. The Customer's generator disconnect switch²⁶ may be opened by the Company (i.e., isolating the Customer's generating equipment), without prior notice to the Customer, for any of the following reasons:

- System emergency operations require such action.
- Company periodic checks of Customer's interfacing equipment reveal a hazardous condition, or lack of necessary maintenance for equipment necessary to protect the Company's EPS.
- Generating equipment interferes with other customers or with the operation of the Company's EPS.
- When required protective relaying and/or tele-protection is altered, inoperable, or missing
When required special equipment necessary for operating control (e.g., telemetering/SCADA) on the Company's EPS is inoperable or missing.
- Parallel operation, other than for **MA SIDG** testing of type tested inverters, prior to Company approval to interconnect.
- Failure to make available records of verification tests and maintenance of the Customer's protective devices designated by the Company, unless otherwise specified in the **MA SIDG**.
- Situations where the area EPS is in a non-normal operating scenario and the generator has not been studied for interconnection in that specific operating scenario.

13.0 REVISION HISTORY

<u>Version</u>	<u>Date</u>	<u>Description of Revision</u>
1.0	06/01/07	Initial version of new document superseding all previous revisions of ESB 756.
1.1	07/29/11	September 2010 ESB 750 Series Errata changes, formatting, and general editing.
2.0	05/11/12	Revised and formatted incorporating tech requirements of MA DPU 1219 Dec. 2009.
3.0	07/15/15	Revise entire document for MA DPU 1219 May 2013 MA DPU 1320 June 2015 and technical updates.
4.0	08/03/17	June 2017 revise for MDPU 1320 October 2016, IEEE 1547a amendment, and technical updates.
4.1	12/15/17	October-December 2017 interim amendments to Sections 5.1.1.2, 7.6.11, and 7.8.
4.2	02/09/18	January-February 2018 interim amendments to Sections 7.6.11, 7.6.12, and 7.8.
5.0	06/29/18	June 2018 revised for IEEE 1547-2018 and updated National Grid practices.
6.0	12/04/19	December 2019 revised for updated National Grid practices.

EXHIBITS ATTACHED

²⁶ Refer to Section 7.4 regarding technical requirements for draw-out breakers over 600V and the Company's ESB 750.

EXHIBIT 1: Company Requirements for Projects Not Eligible for the Simplified Process

These are Company items to be considered in the Customer's DER Project Schedule.

ID	Activity Description	MA SIDG § or ESB ref.
Project Definition & Conceptual Analysis Phase		
1	Customer M.D.P.U. 1320 Exhibit B Expedited/Standard Interconnection Application Form w/technical submittal & prelim. design received	3.3 or 3.4, Figure 1, Table 1
2	Company Preliminary Technical Assessment & cost estimate for Impact or Detailed Study	3.0, Table 2
3	Company M.D.P.U. 1320 Exhibit F or G Retail Connection Agreement executed with Customer	Exhibit F or G
4	Customer commits to Impact or Detailed Study and provides advance payment	5.0
Final Design Review Phase		
5	Company completes Impact or Detailed Study/Service Plan	3.2 or 3.3, Figure 1, Table 1
6	Customer commits to utility system modifications in Impact or Detailed Study/Service Plan and provides advance payment	4.0, 5.0
7	Customer's project schedule and final design & specifications received	4.0 – 8.0, ESB 750 & 752 or 753 or 754 or 758
8	Company reviews Customer's design & returns comments	4.0 – 8.0, ESB 752 or 753 or 754 or 758
Installation Progress Review Phase		
9	Customer's corrected design, test reports & settings received	4.0 – 8.0, ESB 752 or 753 or 754 or 758
10	Company reviews Customer's design & returns comments	4.0 – 8.0, ESB 752 or 753 or 754 or 758
11	Company field audit of Customer's installation progress	4.0 - 6.0
Installation Compliance Verification Phase		
12	Customer's advance notice of functional testing received	4.2.4, ESB 755
13	Electrical inspection certification approval received from municipal codes enforcement	ESB 750 & 752 or 753 or 754 or 758
14	Customer's acknowledgement of satisfactory wiring & relay calibration tests received	4.2.4, ESB 755
15	Company witness of Customer's functional testing	4.2.4, ESB 755
16	Company field audit of Customer's service connection	4.0 – 6.0, ESB 750 & 752 or 753 or 754 or 758
17	Customer resolves open items	ESB 750 & 752 or 753 or 754 or 758
Energization & Synchronization Phase		
18	Verification testing satisfied	4.2.4
19	Company's metering installation complete	8.0, ESB 750 & 752 or 753 or 754 or 758
20	Company's supply system interconnection complete	4.0, 5.0
21	Company review/acceptance of Customer's resolved open items	
22	Customer's Certificate of Completion received (and energization sequence plan for interconnections >600V)	3.2 or 3.3, ESB 755
23	Company proceeds with energization	
24	Customer is permitted to synchronize generation facility in parallel to the Company's supply	
Project Closeout Phase		
25	For interconnections >600V, remainder of Customer's protective system functional testing documented in an acknowledgement letter submitted to the Company within 10 business days after energization	ESB 755
26	Customer's as-built design drawings received within 90 days for interconnections >600V	ESB 750 § 1.7
27	Company reconciliation of project costs with Customer	When requested by Customer.

EXHIBIT 2: Reference Maps of National Grid Massachusetts Secondary Network EPS Areas

Bay State North/West Division

Lynn:

http://www.nationalgridus.com/masselectric/non_html/Lynn_Network_Feeder_Final_08-17-12.pdf

Worcester:

http://www.nationalgridus.com/masselectric/non_html/Worcester_Network_Feeder_Final_08-17-12.pdf

Bay State South Division

Brockton:

http://www.nationalgridus.com/masselectric/non_html/Brockton_Network_Feeder_Final_09-12-12.pdf

National Grid customers in the downtown districts of Brockton, Lynn, and Worcester **should check the National Grid Website under: “Area Network Maps”** [http://www.nationalgridus.com/masselectric/business/energyeff/4_networkmap.asp]. **If that street location is highlighted (or near) the red line, contact the Company’s DGES department via E-mail addressed to Distributed.Generation@nationalgrid.com to determine if the proposed location is served in National Grid’s Secondary Network area.**

EXHIBIT 3: Distribution Secondary Grid and Spot Network Description

In Massachusetts, National Grid generally has two types of electrical distribution systems: radial and distribution secondary network systems. While the vast majority of customers are served from radial power systems, some customers in the downtown districts of Brockton, Lynn, and Worcester in Massachusetts are served by distribution secondary network systems; see **Exhibit 2** for area maps. These systems are designed to meet the higher reliability needs, dense load levels, and limited space commonly encountered in urban areas.

A distribution secondary network system delivers electricity through a complex and integrated system of transformers and underground cables that are connected and operate in parallel. Power can flow in either direction on the secondary service delivery lines, commonly called secondary distribution lines. The loss of a single line or transformer in a secondary network system does not cause an interruption of power, unlike radial systems where there is only one line and one path for power to flow from the distribution substation to the customer's point of service. If a radial system experiences an outage, service is interrupted to the customers until repairs are completed; this is less likely to be the case in a distribution secondary network system.

In distribution secondary network systems, devices called “network protectors” are usually arranged to automatically connect its associated transformer to the network system when conditions are such that the transformer when connected will supply power to the network and to automatically disconnect the transformer from the network when power flows from the network to the transformer. The integration of DER into a distribution secondary network system may result in network protectors exceeding their original design criteria or nameplate ratings.

Example Distribution Secondary Grid Network Diagram

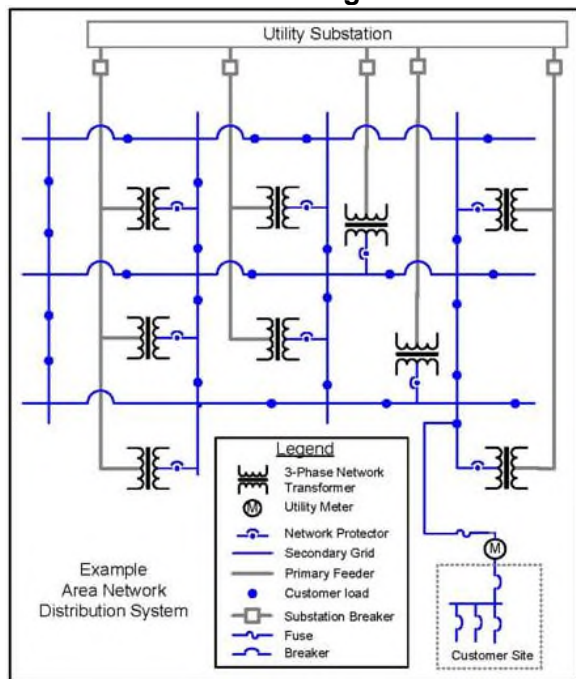

Underground secondary grid (area) network systems deliver power to each customer through a complex and integrated system of multiple transformers and underground cables that are connected and operate in parallel.

Example Distribution Secondary Spot Network Diagram

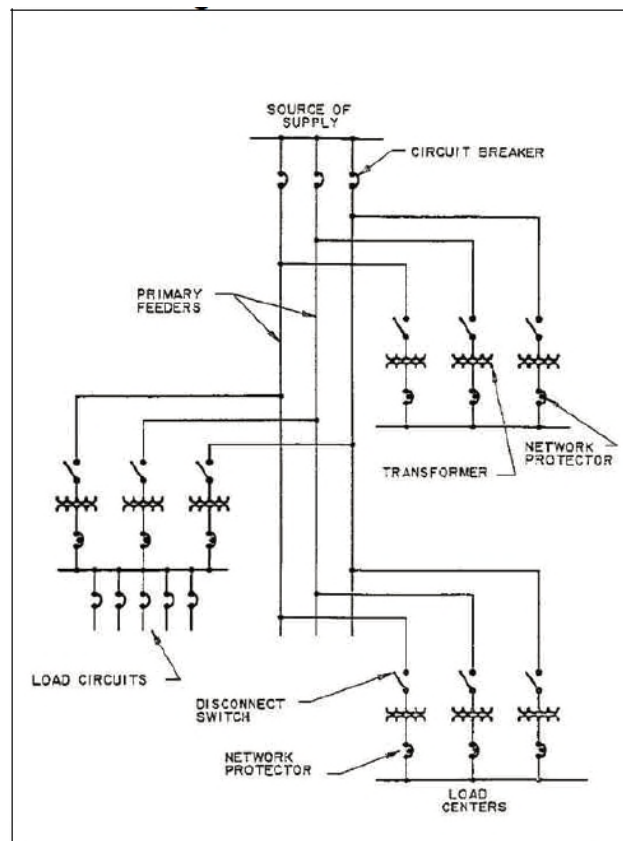

Spot networks are similar to grid (area) networks except they serve a single premise.

EXHIBIT 4: Recommended Guidelines for Residential and Commercial Single-line Diagram Submittals

Refer to **Figures 2 and 3** for typical illustration and symbology.

1. Identify the project, Company's electric service order (ESO) number, location and submitter's name and address.
2. Indicate standard and any non-standard system voltages, number of phases, and frequency of the incoming circuit. Indicate wye and delta systems; show whether grounded or ungrounded.
3. Identify cable, conductors and conduit, the type and number. The Company is interested in how the power is getting from the service point to the protective equipment.
4. Identify wiring troughs and/or junction boxes where used.
5. Use standard symbols. See **NFPA 70B** or **IEEE Standard 141** for symbols in typical electrical single-line diagram development.
6. Identify the service equipment's switch and fuse or circuit breaker as to manufacturer, type, rating, catalog number, etc. Service equipment must be able to safely interrupt the maximum available fault current from the supply; refer to **NEC** Articles 110 and 230.
7. Show billing meter trough or instrument transformers' cabinet (C.T. cabinet) in circuitry. Indicate source and load for the circuit. Refer to Section 7 in the Company's **ESB 750** for acceptable metering configurations.
8. Identify other protective devices and ratings. Include ratings in volts and amps, the interruption rating, and type and number of trip coils on circuit breakers. Also, note any special features of fuses (current limiting, dual element, etc.).
9. Identify ratios of current and potential transformers, taps to be used on multi-ratio transformers, and connection of dual ratio current transformers if used.
10. Identify any relays, if used, and their functions. Indicate which interrupting device(s) are tripped by the relay(s) used.
11. Show connections, winding configuration, and ratings of power transformers for any to be used. Show the transformer impedance and X/R ratio.
12. Indicate the connections, winding configuration and ratings of grounding transformers if any are to be used. Show the impedance and X/R ratio.
13. Identify Generator Disconnect and its ratings, the service point, and the PCC.
14. Provide catalog cut-sheets clearly identifying exact model to be installed for devices and equipment of mutual interest to the Company and of the Customer. Equipment shall be inclusive but not limited to the main service arrangement, any transformer in the circuit path between the point of common coupling and the generator, the generator interrupting device, the utility disconnect, and inverter(s) and/or relay(s).

FIGURE 1: Sample Residential Photovoltaic Distributed Generator Installation – Single Phase, Net Metered

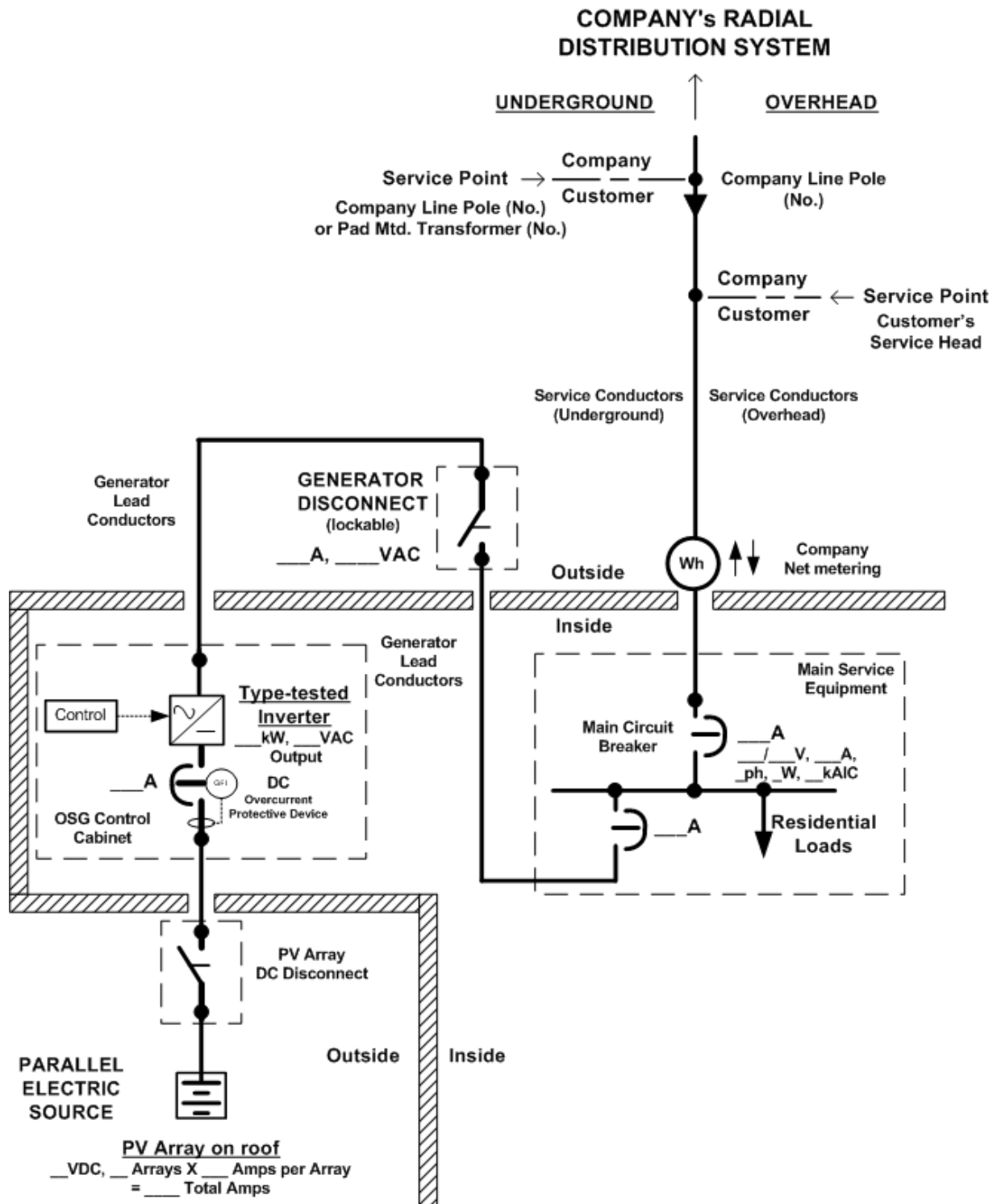
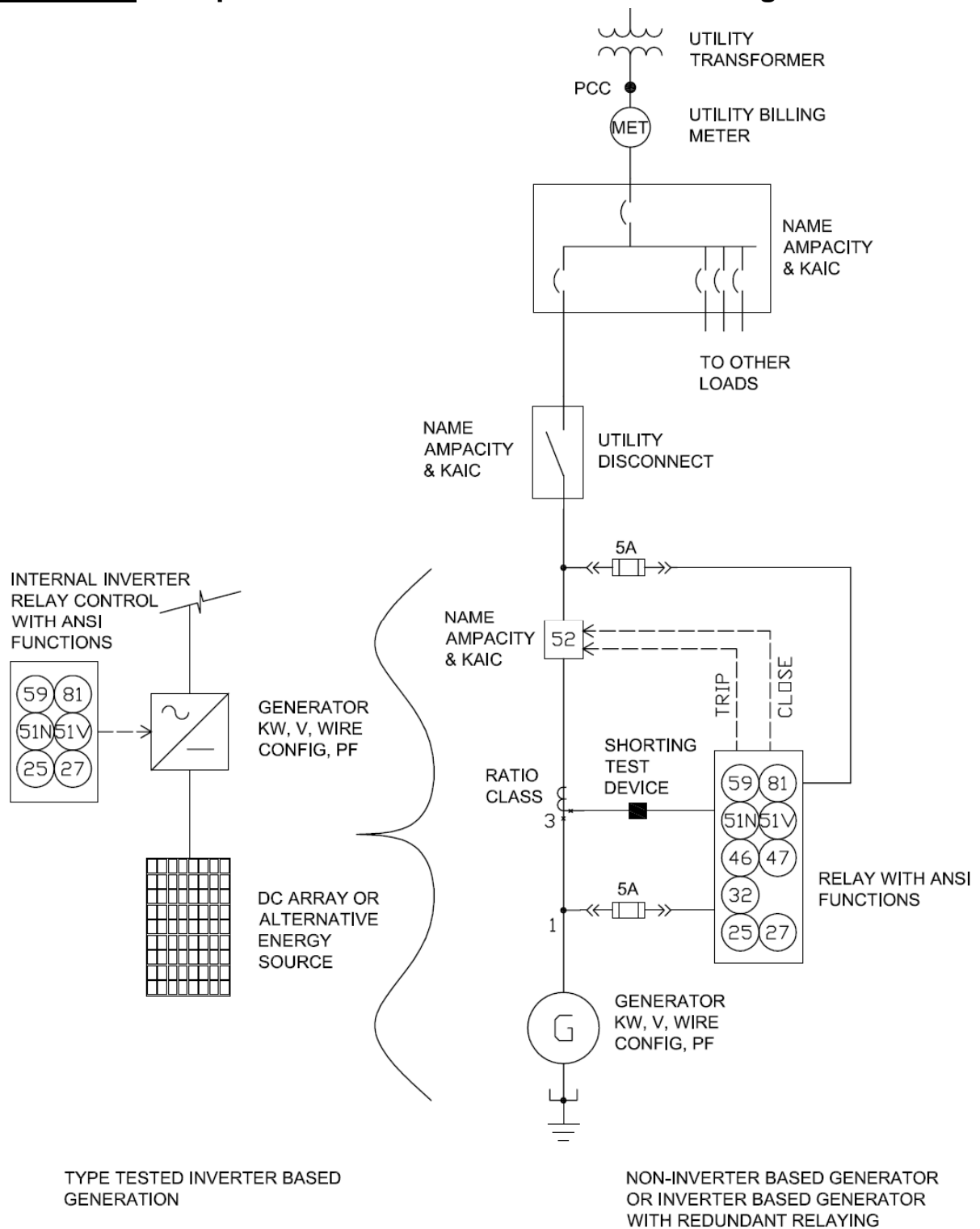

FIGURE 2: Sample Distributed Generator One-Line Diagram



[TYPICAL ONLY]

FIGURE 3: Typical Symbolology for Electrical Drawings

ELEMENTARY SWITCH DEVICES								CONTACTS AND RELAYS		
FLOW		PRESSURE		LIQUID LEVEL		TEMPERATURE		CONTACTS		
CLOSED RISING	OPENS RISING	CLOSED RISING	OPENS RISING	CLOSED RISING	OPENS RISING	CLOSED RISING	OPENS RISING	NORMALLY OPEN OR "a" CONTACT	NORMALLY CLOSED OR "b" CONTACT	
LIMIT				PUSHBUTTON		RELAY COIL				
NORMALLY OPEN	NORMALLY OPEN - HELD CLOSED	NORMALLY CLOSED	NORMALLY CLOSED - HELD OPEN	NORMALLY OPEN	NORMALLY CLOSED					
ELEMENTARY FUSE DEVICES			BATTERY OR DC SOURCE		CONNECTIONS					
FUSE	SOLID LINK	IN REMOVABLE CARTRIDGE OR PULL BLOCK	GENERAL OR SINGLE CELL	MULTI CELL (COMMON)	GROUND	SHORT CIRCUIT (3-PHASE CONNECTION)	SEPARABLE CONNECTORS OR DRAW OUT FEATURE			
DISCONNECTS (UNDER 600 V)		CIRCUIT BREAKERS			TRANSFER SWITCH					
NON-FUSED DISCONNECT	FUSED DISCONNECT	GENERIC OR AIR TYPE	CB OR INTERRUPTING DEVICE (OTHER THAN AIR)	TWO POSITION	THREE POSITION					
CAPACITOR	ANTENNA	THERMAL OVERLOAD	INDICATING LIGHT * = LENS COLOR:							
				A - AMBER B - BLUE C - CLEAR G - GREEN O - ORANGE P - PURPLE R - RED W - WHITE Y - YELLOW						
TRANSFORMERS AND INSTRUMENT TRANSFORMERS										
3-PHASE, WYE		3-PHASE, DELTA					3-PHASE ZIGZAG			
GROUNDING NEUTRAL	UNGROUNDING	DELTA	CORNER GROUNDING	OPEN DELTA	OPEN DELTA CORNER GROUNDING	BROKEN DELTA	UNGROUNDING	GROUNDING		
GENERIC TWO WINDING TRANSFORMER	GENERIC THREE WINDING TRANSFORMER, TERTIARY TYPE	CURRENT TRANS. WITH POLARITY MARKS SHOWN		EXTERNAL TO BUSHING		BUSHING MOUNTED	FUSED POTENTIAL TRANSFORMER			
				■ OR ● OR ×						

EXHIBIT 5: Recommended Guidelines for Functional Single-line Diagram Submittals

Refer to Figures 1 and 2 for typical illustrations.

In addition to Exhibit 4:

15. On functional single-line diagram submittals, industry standard device numbers are necessary. Refer to the following List of Standard Device Numbers (See latest edition of **ANSI C 37.2**):

<u>Device Number</u>	<u>Function</u>
25	Synchronizing Device /Synchronism check device
27	Undervoltage Relay
32	Directional Power Relay
46	Negative Sequence Voltage
50	Instantaneous Overcurrent Relay
51	Phase Overcurrent Relay
51N	Neutral Overcurrent Relay
51G	Ground Overcurrent Relay
51V	Overcurrent Relay, voltage restraint
51C	Voltage controlled overcurrent
52	Breaker
52R	Recloser
59	Overvoltage Relay
59G	Neutral Over Voltage Relay
59N	Zero Sequence Over Voltage Relay
62	Time-delay Stopping or Opening Relay
64	Ground Protective Relay
81	Over and Under Frequency Relay
86	Lockout Relay
87	Differential Relay

FIGURE 4: Sample Functional Single-Line Diagram

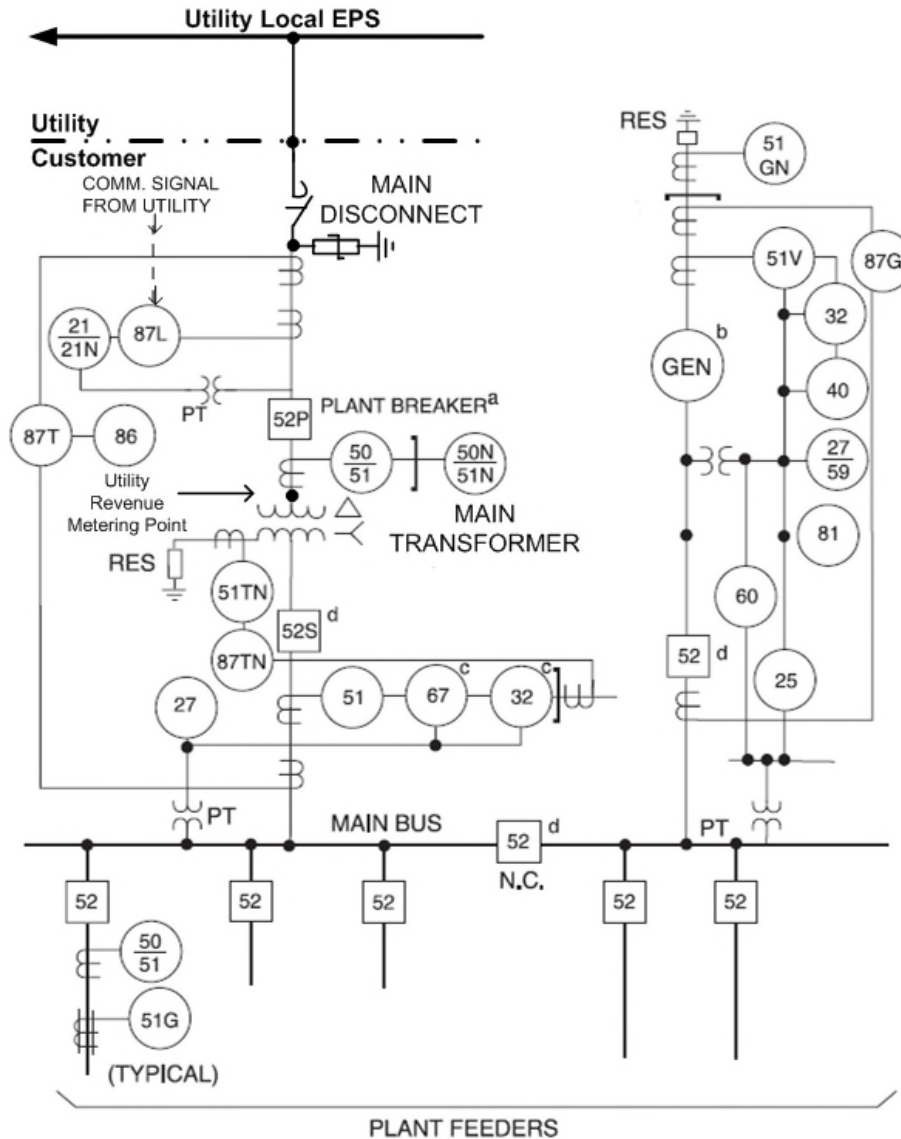

- NOTES:
- a. A fused interrupter switch may also be used instead of the breaker.
If fused interrupter is used, relaying associated with the transformer is not used.
 - b. In-plant generator for partial plant load and back-up.
 - c. Devices 67 and 32 are directional. Polarity of CTs and PTs must be verified.
 - d. Overcurrent and bus differential protection should be provided for the main, generator, and tie breakers, but protection is not shown here. See IEEE Std. C37.95 and C37.97.
- Trip function lines not shown.
See IEEE Std. 242 Buff Book "Recommended Practice for Protection and Coordination of Industrial and Commercial Power Systems" for more information.

[TYPICAL ONLY]

FIGURE 5: Typical $3V_0$ Requirements for Local EPS Ground Fault Detection

The Company requires ground fault protection on any system that can be a generation source to protect any equipment that can be parallel supplied from two sources. In the cases where the primary winding of the transformer supplying the facility is delta, a “zero-sequence” voltage or “ $3V_0$ ” scheme is required. Typically, this is implemented by installing potential transformers (PTs) on the primary system as a source to a voltage sensing relay containing a ground overvoltage device function (59N or 59G) capable of detecting the presence of a single line-to-ground fault on the Local EPS.

Notes:

1. The Company may waive this requirement depending on the restrictions of the local EPS.
2. Trip signal is shown to remove generator from Company’s EPS at the generator interrupting device. Alternatives may be proposed for Company approval for alternative arrangements.
3. Yg-Broken Delta arrangement is typical of an electromechanical relay installation while Yg-Yg is commonly applied for a microprocessor relay installation.

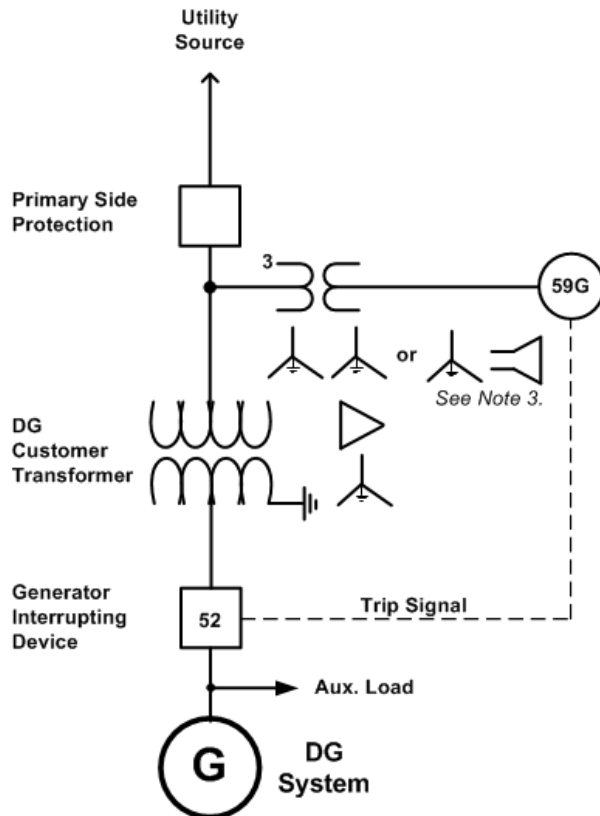

-- INFORMATION ONLY --
 -- SIMPLIFIED DIAGRAM NOT
 ALL DETAILS SHOWN --

EXHIBIT 6: Typical Overhead Primary Service Configuration in MA for Large DER Installations

The Customer will be required to install a pole to the Company's specifications on which the Company will install cross arms and dead end the Company's primary service conductors. This point will be the physical Point of Common Coupling (PCC). At this pole the Customer-owned, 3-phase gang operated, Generator Disconnect switch can be installed and connected to the Company's primary service conductors by the Customer.

All Company-owned service lateral facilities and equipment on private property will require easements. These easements will be the responsibility of the Customer to obtain in accordance with the Company's specific electric service requirements; see ESB 750.

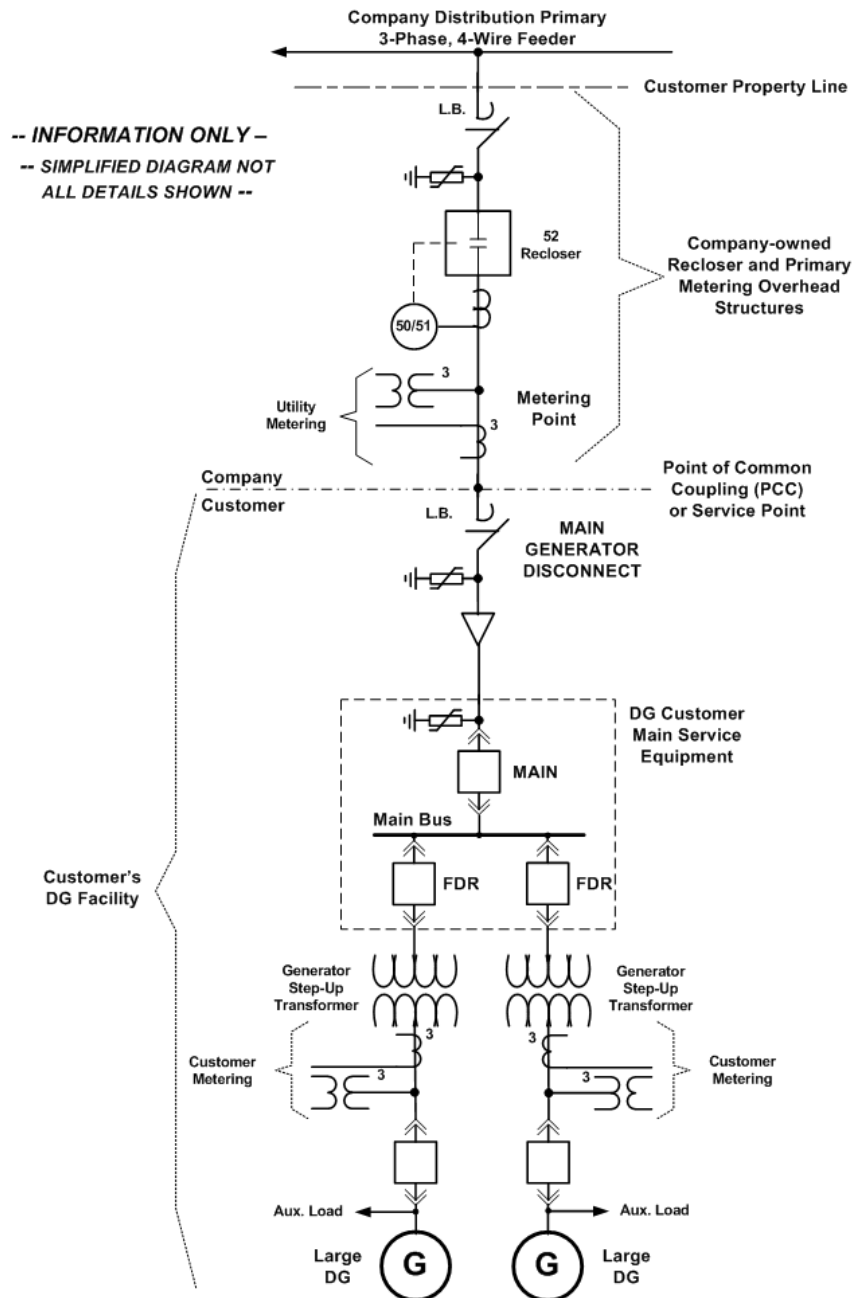

EXHIBIT 7: Net Metering Compliance Verification Checklist (Simplified Process)

Account Number: _____ Email: _____
Customer Name: _____ Last First Phone # _____
Work Phone # _____
Service Address: _____
Number Street Town/City Zip
Billing Address: _____
Number Street Town/City Zip
Qualified Installer: _____ License # _____ Phone # _____
Last First (if available) Cellular # _____
Address: _____ FAX # _____
Number Street Town/City Zip Email: _____

✓ **Verify One-Line Diagram (installed equipment)**

_____ UL 1741 Certified Inverter Model _____
_____ Software version _____
_____ Company billing meter s/n _____ Net-meter One Meter Option: **YES** ___ **NO** ___
_____ Inspection received? **YES** ___ Number _____ (attach copy of approval certificate)
NO ___, then stop and await inspection approval.

✓ **Verify Plot Plan (equipment's location)**

_____ "Generator Disconnect Switch" is at agreed location: **YES** ___ **NO** ___.
_____ "Generator Disconnect Switch" is labeled as such: **YES** ___ **NO** ___.
_____ Label is at meter location to identify location of Generator Disconnect: **YES** ___ **NO** ___.

✓ **Verify DG System Is Operating (producing power)**

_____ Verify "Generator Disconnect Switch" is **Open**.
_____ Verify voltage is **zero volts** on DG side of open "Generator Disconnect Switch": **YES** ___ **NO** ___.
_____ **Close** "Generator Disconnect Switch".
_____ Verify DG inverter **alarms** and **voltage present** on utility side of "Generator Disconnect Switch":
YES ___ **NO** ___.

✓ **Restoration of Utility Power Test**

_____ **Open** "Generator Disconnect Switch", **pause at least 1 to 2 minutes**, then **Close** "Generator Disconnect Switch". Record time when "Generator Disconnect Switch" is closed: _____
_____ Record time when **DG Inverter starts** producing power: _____. Is the time between the "Generator Disconnect Switch" closure and when DG Inverter permits synchronization to utility source **greater than 5 minutes**? **YES** ___ **NO** ___

✓ **24-hour Telephone Number Contact**

Name: _____ Number (____) _____

Performed by: _____ signature: _____ Date: _____
Name (Customer's qualified installer)

Witnessed by: _____ signature: _____ Date: _____
Name (Company witness)

Electric System Bulletin No. 756 Appendix D:
**Distributed Generation Connected to National Grid
Distribution Facilities per the Rhode Island Standards
for Connecting Distributed Generation**

Version 5.0,12/04/2019

ESB 756 Appendix D is part of the ESB 750 series

TABLE of CONTENTS

SECTION	PAGE
TABLE of CONTENTS.....	2
1.0 Purpose	4
2.0 Scope.....	5
3.0 Applicable Codes, Standards and Guidelines.....	5
4.0 Definitions	6
5.0 Interconnecting Customer Interface Procedures.....	7
5.1 APPLICATION PROCESS OVERVIEW	7
5.1.1 Customer Technical Data Submission.....	8
5.1.1.1 Control Diagrams	8
5.1.1.2 Interconnection Facility Equipment Data Sheets.....	8
5.1.1.3 Site Plan.....	8
5.1.1.4 Data Required for Energy Storage System Applications.....	8
5.1.1.5 Data Required for Facility or Campus-style Microgrid Applications.....	9
5.2 INTERCONNECTION PROCESS FOR DER NOT ELIGIBLE FOR THE SIMPLIFIED PROCESS .9	9
5.3 OBJECTIVES IN THE APPLICATION PROCESS	9
5.4 CONSIDERATIONS DURING THE APPLICATION PROCESS FOR DER INTERCONNECTIONS	
IN THE SECONDARY GRID AND SPOT NETWORK AREAS	11
5.5 INTERCONNECTION CHARGES	12
Table 5.5-1: DER Projects where no EPS upgrades are expected	13
Table 5.5-2: Complex DER Projects.....	13
6.0 Potential Issues Related to Interconnection.....	13
6.1 GENERAL CONSIDERATIONS	13
Illustration 6.1.5-1: Typical DG Installation Areas on Radial Distribution Feeders.....	14
6.2 SIGNIFICANT EPS CONSIDERATIONS	15
6.2.1 Direct Transfer Trip	15
6.2.2 Transmission Ground Fault Detection	15
Illustration 6.2.2-1: Simple One Line for Transmission Ground Faults for Typical	
Substation Transformer Configuration.....	17
7.0 General Design and Operating Requirements	17
7.1 GENERAL CRITERIA.....	18
7.1.1 Single Phase.....	18
7.1.2 Three Phase	18
7.1.3 Phase Balance and Voltage Tolerance	18
7.1.4 Neutral Stabilization, Ground Faults, and Grounding.....	18
7.2 SERVICE EQUIPMENT AND REVENUE METERING	19
7.2.1 Service Equipment Requirements.....	19
7.2.2 Company Revenue Metering Requirements.....	21
7.2.3 Company Revenue Metering Requirements (RI REGrowth Program).....	21
Illustration 7.2.3-1 Typical RI REGrowth Metered Service.....	21
7.3 TRANSFORMER	22
7.3.1 Secondary Served Customers	22
7.3.2 Primary and Higher Voltage Served Customers.....	22
7.3.2.1 Effectively Grounded, Four-wire Multi-grounded 3-phase Wye EPS:.....	23
7.3.2.2 Not Effectively Grounded, Three-wire 3-phase EPS:.....	23
7.4 MANUAL GENERATOR DISCONNECTING MEANS	23
7.5 GENERATOR INTERRUPTING DEVICE REQUIREMENTS	25
7.5.1 General.....	25
7.5.2 Local Power Supply Requirements	25
7.6 PROTECTION AND PROTECTIVE EQUIPMENT REQUIREMENTS	26
7.6.1 Type Tested (Certified) Equipment.....	27
7.6.2 Non-Type tested Equipment.....	27
7.6.3 Number of Relays Required.....	27

TABLE of CONTENTS

<u>SECTION</u>	<u>PAGE</u>
7.6.3.1 Certified Inverter-based Energy Resource Protection Requirements.....	27
7.6.3.2 All Non-Certified Energy Resource Protection Requirements	28
7.6.4 Instrument Transformers for Protective Device Relays.....	28
7.6.4.1 Current Transformers (CT)	28
7.6.4.2 Voltage Transformers (VT) and Connections.....	28
7.6.5 Protective Relay and Trip Circuit Hard-Wire Requirements	29
7.6.6 Protective Relay Test Switch Requirements.....	29
7.6.7 Voltage Relay Devices	29
7.6.8 Frequency Relay Devices	29
7.6.9 Synchronizing Devices.....	29
7.6.10 Overcurrent Relays	30
7.6.11 Utility Grade Relay and Protective Device Settings and Verification	30
7.6.11.1 Default Voltage and Frequency Set Points for All Types of Energy Resources	30
Table 7.6.11.1-1 Utility Grade Relay and Parallel Generation Default Voltage & Frequency Set Points	30
7.6.11.2 Synchronism Check Setting Requirements for all types of Generation	30
Table 7.6.11.2-1 Relay Settings to Parallel with the Company EPS.....	30
7.6.11.3 Company-designated Relays and Customer Settings.....	30
7.6.11.4 Company Verification of Relay Testing.....	31
7.6.12 Unintentional Islanding Protection for DER.....	31
7.6.12.1 General	31
7.6.12.2 Islanding Risk Mitigation Methods Required	32
7.6.12.3 Certified DER	32
7.6.12.4 Non-Certified & Voltage or Frequency Regulating Inverters, Induction & Synchronous Machines	33
7.7 MONITORING AND CONTROL (M&C) AT DER FACILITY	33
7.7.1 For Independent Power Producer (IPP) – “Utility Connected Stand Alone” projects (DER with no load).....	33
7.7.2 For Non IPP - “Behind the meter” projects (DERs with customer Load)	34
Table 7.7.2-1: RTU Requirements by Facility Size	34
7.8 VOLTAGE AND FREQUENCY RIDE THROUGH AND CONTROL REQUIREMENTS.....	35
7.8.1 Voltage and Frequency Ride Through.....	35
7.8.2 Voltage and Frequency Control.....	35
Table 7.8.2.3-1: Default Mode Settings for Inverter-based Utility Interactive DER	35
7.8.3 Return to Service	35
Table 7.8.3-1: Return to Service Parameters for DER.....	35
8.0 Testing and Commissioning.....	35
9.0 Operating.....	36
10.0 Power Quality Monitoring	36
10.1 POWER QUALITY COMPLIANCE VERIFICATION.....	36
10.2 POWER QUALITY DISTURBANCE AND MITIGATION	37
10.3 TRANSIENT OVERVOLTAGE / LOAD REJECTION OVERVOLTAGE (LROV)	37
11.0 Facility Audit.....	37
12.0 Disconnection by the Company (Isolation)	37
13.0 REVISION HISTORY	38
EXHIBITS ATTACHED.....	38
EXHIBIT 1: COMPANY REQUIREMENTS FOR PROJECTS NOT ELIGIBLE FOR THE SIMPLIFIED PROCESS.....	39
EXHIBIT 2: REFERENCE MAPS OF NATIONAL GRID RHODE ISLAND SECONDARY NETWORK EPS AREAS	40
EXHIBIT 3: DISTRIBUTION SECONDARY GRID NETWORK DESCRIPTION.....	41

TABLE of CONTENTS

<u>SECTION</u>	<u>PAGE</u>
EXHIBIT 4: RECOMMENDED GUIDELINES FOR RESIDENTIAL AND COMMERCIAL SINGLE-LINE DIAGRAM SUBMITTALS	42
FIGURE 1: SAMPLE RESIDENTIAL PHOTOVOLTAIC DISTRIBUTED GENERATOR INSTALLATION – SINGLE PHASE, NET METERING.....	43
FIGURE 2: SAMPLE COMMERCIAL DISTRIBUTED GENERATOR INSTALLATION	44
FIGURE 3: TYPICAL SYMBOLOGY FOR ELECTRICAL DRAWINGS	45
EXHIBIT 5: RECOMMENDED GUIDELINES FOR FUNCTIONAL SINGLE-LINE DIAGRAM SUBMITTALS	46
FIGURE 4: SAMPLE FUNCTIONAL SINGLE-LINE DIAGRAM	47
FIGURE 5: TYPICAL 3V₀ REQUIREMENTS FOR LOCAL EPS GROUND FAULT DETECTION	48
EXHIBIT 6: TYPICAL OVERHEAD PRIMARY SERVICE CONFIGURATION IN RI FOR LARGE DER INSTALLATIONS 500 kW AND ABOVE.....	49
EXHIBIT 7: NET METERING COMPLIANCE VERIFICATION CHECKLIST (SIMPLIFIED PROCESS) ..	50

1.0 Purpose

1. Electric System Bulletin (ESB) 756 Appendix D covers requirements for interconnecting customers proposing to install a distributed energy resource (DER) system (“Interconnecting Customer” or “Customer”) to National Grid’s (“the Company”) Rhode Island electric power system (EPS) for State jurisdictional projects.
2. ESB 756 Appendix D does not cover the technical federal and state transmission operator jurisdictional requirements New England Independent System Operator (ISO-NE) and Federal Energy Regulatory Commission (FERC) for connection to the Company’s transmission EPS, community microgrids, and parallel operated DER systems and on-site generators (OSG) that are covered by the Company’s ESB 756 Appendix A.¹
3. This ESB supplements **ESB 750** and the R.I.P.U.C.2180² The Narragansett Electric Company Standards for Connecting Distributed Generation (RI SCDG; see http://www9.nationalgridus.com/non_html/RI_DG_Interconnection_Tariff.pdf)
4. The **RI SCDG** provides general technical requirements, recommendations, and assistance to customers regarding the DER facilities connected in parallel to the Company’s distribution electric power system (Company Distribution EPS). These projects are typically 5 MWs or smaller in size. Note that the RI SCDG does not apply to DER facilities, or group of facilities, having specific requirements under ISO-NE³ Operating Procedures No. 14 and No. 18 and where wholesale DER connections are proposed. Each DER interconnection project will be individually evaluated relative to its unique technical and engineering parameters. As such, the Company reserves the right to amend or revise the technical requirements of this document, should it be justified by a project’s unique circumstances.
5. ESB 756 and this Appendix D are available from the Company’s website at <http://www.nationalgridus.com/electricalspecifications> and in printed form by contacting the Call Center in Massachusetts (see inside cover of ESB 750 for Customer Service Center telephone numbers). However, since printed copies may not reflect the latest updates, please refer to the Company’s website for the latest authorized versions.

¹ If deemed as a FERC jurisdictional projects, the Customer will need to apply and work with the ISO-NE (http://www.iso-ne.com/genrtion_resrcs/nwgen_inter/index.html) for interconnection to the distribution system, following the application requirements of the FERC Small Generator Interconnection Procedure (SGIP) and ISO-NE Schedule 23.

² Rhode Island Public Utilities Commission (PUC or R.I.P.U.C.).

³ Independent System Operator (ISO) for New England (NE); see <https://www.iso-ne.com/>.

2.0 Scope

1. This Appendix D to ESB 756 is provided to assist a Customer desiring to interconnect a generator facility to National Grid's EPS to meet requirements for all generating interfacing equipment to be designed, installed, interconnected, tested, and operated in accordance with applicable government, industry, and Company standards.
2. These requirements are limited and apply to only those types of parallel generation and energy storage systems covered by the RI SCDG connected to the Company EPS with a nameplate rating of 5 MW or less including other distributed energy resources (DER) facility or campus-style microgrids, and where DER owners, or DER owners as clients of registered aggregators, sign onto a retail tariff with the intent to sell energy or ancillary services to the retail market. For FERC jurisdictional projects connected to the Company Distribution EPS, the technical provisions of this document also apply in conjunction with ESB 756 Appendix A. Where conflicts arise, the technical provisions of ESB 756 Appendix D take precedence.
3. These requirements apply only to those points in which the Customer and the Company have a mutual interest of the DER facility's or premises' wiring service connection to ensure safety to Company employees and the public as well as satisfactory operation, compatibility, and reliability with the electrical supply to others served by the Company's EPS. This includes, but not limited to:
 - the location of the service point and facilities under the Company's exclusive control, such as the Company's metering to be installed at any point on either side of the service point;
 - service lateral;
 - service equipment; and
 - the Company's need to automatically isolate parallel sources of the DER facility from the EPS should there be an unacceptable disturbance, event, or condition within the facility.Conditions of electric service are based on governmental laws or regulations that determine the Company's authority to provide electric service under their tariffs. See 90.2(B)(5) in the National Electrical Code® and the Company's ESB 750 for more information.
4. For the Company's interconnection process requirements of the RI SCDG, please refer to the retail tariff requirements at the following Company website:
RI: http://www9.nationalgridus.com/narragansett/business/energyeff/4_interconnection-process.asp
5. These requirements may also be applied, at the discretion of the Company, to other methods used to generate electricity in parallel with the Company's EPS, including but not limited to energy storage system (ESS) facilities, regenerative drives used in elevators, and component power inverters used in exercise equipment and any other micro-scale type energy recapture systems.

3.0 Applicable Codes, Standards and Guidelines

1. The Customer's DER facility shall conform to the latest revision of all local, state and federal codes and national standards that apply, including issued amendments unless the Company has taken exception to such standard. Specific codes and standards applicable to this bulletin include, but are not limited to:
 - Institute of Electrical and Electronics Engineers (IEEE) Std. 1547 "Standard for Interconnection and Interoperability of Distributed Energy Resources with Associated Electric Power Systems Interfaces"
 - Underwriters Laboratories (UL) Std. 1741 "Standard for Inverters, Converters, Controllers and Interconnection System Equipment for Use With Distributed Energy Resources"
 - ANSI/IEEE C2 "National Electrical Safety Code®" (NESC)

- NFPA 70 “National Electrical Code®” (NEC)
 - NFPA 70B “Recommended Practice for Electrical Equipment Maintenance”
 - NFPA 70E “Standard for Electrical Safety in the Workplace”
 - NETA-MTS "Maintenance Testing Specifications for Electrical Power Distribution Equipment and Systems"
2. The Customer’s DER facility shall also conform to any applicable requirements of the Rhode Island PUC and any local, state, federal and/or other agencies from which a review, approval, or a permit is required.
- The minimum “fall zone” clearance of wind turbine generators (WTG) shall be in accordance with the local governmental authority having jurisdiction (AHJ) and in any case, shall not be less than 125% of maximum WTG height measured horizontally to the Company’s overhead distribution lines.
 - Refer to ESB 750 for additional information regarding specifications for electrical installations. The Customer is responsible for securing and coordinating all required easements and permits for installation of equipment on the proposed site.
3. The Customer shall comply with the latest revision of the appropriate Company ESB or tariff requirements, which cover details for the Customer’s electric service installation. These include:
- **ESB 750** - Specifications for Electrical Installations
 - **ESB 751** - General Requirements Above 600-Volt Service⁴
 - **ESB 752** - Service Above 15,000 volts
 - **ESB 754** - Outdoor Pad Mounted or Vault Enclosed Single and Three Phase Transformer
 - **ESB 755** - Operation & Maintenance Requirements for Services Above 600 Volts
 - **ESB 758** - Primary Service to Metal Enclosed Gear
 - **R.I.P.U.C. 2180** - The Narragansett Electric Company Standards for Connecting Distributed Generation (RI SCDG)
 - **R.I.P.U.C. 2130** - The Narragansett Electric Company Terms and Conditions for Distribution Service
 - **R.I.P.U.C. 2178** - The Narragansett Electric Company Net Metering Provision
 - **R.I.P.U.C. 2151-C** – The Narragansett Electric Company Renewable Energy Growth for Residential Customers
 - **R.I.P.U.C. 2152-C** - The Narragansett Electric Company Renewable Energy Growth for Non-Residential Customers
 - **R.I.P.U.C. 2098** – The Narragansett Electric Company Qualifying Facility Power Purchase Rate

Refer to **Exhibits 4** and **5** and **Figures 1** through **3** for information when submitting single-line diagrams to the Company’s electronic mail address at Distributed.Generation@nationalgrid.com.

4.0 Definitions

See ESB750, ESB756, and the **RI SCDG** for definitions of special terms. The following terms are defined for the purposes of this document.

⁴ ESB 751 Applies regardless of service voltage for DER systems.

1. **Certified:** Equipment that is approved by examination for safety; see NEC Articles 90 and 110.
2. **Certified DER:** A UL 1741 certified inverter.
3. **Distributed Energy Resource:** An energy source, either distributed generation, storage, or a combination of both, parallel connected to an area EPS.
4. **Generator:** Equipment that produces power.
5. **Generator Set or Genset:** The singular assembly of an electrical generator and a prime mover.
6. **Line section:** Any EPS circuit segment that can be isolated via an automatic interrupting device such as a sectionalizer, recloser, or circuit breaker on three phase circuits; fuses and cut-out mounted reclosers on single phase ground circuits.
7. **Non-certified DER:** Any induction or synchronous DER, or non-UL 1741 inverter.
8. **Prime Mover:** The equipment that drives the generator to output power. For example, in a typical motor operated generator, i.e., M-G set, the motor would be considered the prime mover, or for photovoltaic installations the DC panel arrays on a solar facility would be considered the prime mover.
9. **Recloser:** A line protective device having automatic interruption and controlled reclosing characteristics.
10. **Utility Grade:** Refers to protective device equipment complying with ANSI/IEEE C37.90, ANSI/IEEE C37.90.1 and ANSI/IEEE C37.90.2.

The terms Customer, distributed generator (DG), distributed resource (DR), interconnecting customer (IC), and isolated are defined in the **RI SCDG**.

5.0 Interconnecting Customer Interface Procedures

5.1 Application Process Overview

This section outlines the process for a Customer to receive Company approval to interconnect DER facilities to the Company distribution EPS.⁵ This process is intended for the following:

1. New DER facilities (as aggregated on the customer side of the point of common coupling (PCC)), that are eligible under the **RI SCDG** process and;
2. Review of any modifications affecting the Company distribution EPS and service connection interface at the point of common coupling (PCC) of existing Customer DER facilities that:
 - (i) Have a nameplate rating of 10 MW or less as aggregated on the customer side of the PCC;
 - (ii) Are eligible under the SCDG process; and
 - (iii) Have been interconnected to the Company EPS where an existing retail interconnection agreement and/or power purchase agreement between the Customer and the Company is in place; and

This application process and its requirements do not apply to generation equipment that will never be allowed to operate in parallel with the Company Distribution EPS. For example, this process does not apply to emergency standby generators with break-before-make transfer switches and any other generation sources that operate independently of any connection to the Company Distribution EPS and have no provision for such connection (even for a short period of time).

As stated above, this application process is mandated by the Rhode Island Department of Public Utilities (DPU) for customer generation equipment that will be connected to the Company Distribution EPS on a full or part time basis; see the **RI SCDG**.

⁵ If the Company approves an application to interconnect a DER facility to the Company's distribution EPS, the terms and conditions of that approval will be set forth in an Interconnection Service Agreement, which is a legally binding document that can only be changed by a written document signed by both parties. See Exhibits H and I in the RI SCDG.

5.1.1 Interconnected Customer Technical Data Submission

The Customer shall submit, at the time of application, all relevant documentation as indicated in R.I.P.U.C. 2180. The Company reserves the right to request additional information as needed specific to the interconnection of Customer equipment including, but not limited to, three line diagrams, control diagrams, equipment test reports and other information; see the Company's ESB 750 and 751. The Customer shall provide proof of land ownership or rights to land use.

5.1.1.1 Control Diagrams

The Customer shall submit all control diagrams ("DC control schematics") of the equipment associated with the interconnection protective system. Control diagrams depict all logic used to control the interconnection protective devices. Relay logic diagrams shall be provided for utility-grade relay functions meeting utility requirements.

5.1.1.2 Interconnection Facility Equipment Data Sheets

The Customer shall submit all technical data associated with the specific distribution, protection, and generation equipment included in the project. Submitted documentation shall highlight product numbers and information for specific equipment/devices that will be installed as part of the project. Examples of required documentation specific to DERs include but are not limited to:

- Rotating machine impedance parameters for modeling
- Inverter-based system models and validation test data
- Inverter islanding detection information, including brief description of islanding detection method, parameters monitored, parameters perturbed (for active islanding methods), and whether positive feedback-based methods are to be used
- For 5 MW or greater inverter-based DER, Customer is required to provide a stability model. Please see ("[Guideline for Modelling Inverter-Based DER Greater Than or Equal To 5MW](#)").

5.1.1.3 Site Plan

A site plan shall be submitted showing the location of major customer equipment, the Company equipment to be installed on site, and site details that will be helpful to define accessibility of the site. The site plan shall show the following equipment at minimum:

1. Interfacing transformer
2. Interrupting devices
3. Isolation device(s) (e.g. Generator Disconnect)
4. Point of Common Coupling (PCC)
5. Company pole number nearest the proposed PCC
6. Company line extension to site and from nearest Point of Interconnection
7. Restricted accesses, fences, gates and access controls
8. Existing and proposed Access road(s) including, at a minimum, road material, surface loading criteria, and dimensions to confirm Company personnel and equipment access requirements are met.
9. Generator location
10. Existing service(s)

Site plans shall be to scale with approximate distances indicated, north arrow and scale bar. In addition to site plan, the Company may request an assessor survey map to determine property lines, wetlands and easements. The Customer's site plane shall indicate proposed Utility equipment or pole locations for coordination. Locations of company equipment shall be noted as: "For information purposes only. Final location determined by Utility". Final location of Company equipment is determined by the Company, typically during the design and construction phase.

5.1.1.4 Data Required for Energy Storage System Applications

For applications having ESS proposed, additional information may be required at the time of application for interconnection such as but not limited to:

- Method of ESS connection whether: (1) ESS directly connected to utility EPS; (2) Distributed Generator (DG) and ESS DC coupled; (3) DG and ESS AC coupled; and (4) ESS on load side of service point and utility revenue meter with the premises load, as applicable to the proposal.
- Sequence of operation for the ESS' charging and discharging capabilities and the maximum ramp rate in Watts/second.
- Non-UL 1741 listed inverters will require a utility intertie relay with the appropriate IEEE 1547 functions, settings, and islanding protection according to the Company's [ESB 756](#) jurisdictional requirements.
- Service configuration and revenue metering provisions shall meet the Company's [ESB 750](#) and its applicable supplements.

5.1.1.5 Data Required for Facility or Campus-style Microgrid Applications

Additional information may be required at the time of application for interconnection specific to the facility or campus-style microgrid proposed operation. Facility or campus-style microgrid applications have certain characteristics described here, all of which fall under the U.S. Department of Energy (DOE) definition.⁶ Such microgrids consist of one or more buildings and the relationship with the interconnected utility is characterized as either a single customer-of-record or a single operating entity on one property. These can take several forms such as:

1. A single building under a common property owner with a common customer account. The microgrid has generation resources that can operate in parallel with the electric grid or in island mode.
2. A single building under a common property owner/customer, with multiple direct-metered accounts. The microgrid is configured so that all customers within the building can share the benefits of DER.
3. Multiple buildings owned by a common property owner where microgrid loads and DER are tied with common electric distribution facilities generally not owned by the utility.

These facility or campus-style microgrids are premises wiring systems governed by the National Electrical Code (NEC) as adopted by the local jurisdictional authority.⁷

5.2 Interconnection Process for DER Not Eligible for the Simplified Process

The process for installation of those facilities the Company deems necessary for interconnection of the DER system will be specified by the Company in accordance with the [RI SCDG](#) in response to the Customer's DER interconnection application. See **Exhibit 1** for Company requirements for Projects not Eligible for the Simplified Process.

5.3 Objectives in the Application Process

1. Parallel operation of a generator becomes integrated with the Company EPS, in which the Customer and the Company have a mutual interest. The interconnection must preserve the safety, reliability, security, power quality, and operational efficiency needs of the Company's EPS. This is necessary to ensure safety to the public and to Company employees and satisfactory operation and compatibility with the electrical supply to others. The steps and timing requirements of the application process are identified within the [RI SCDG](#).

⁶ The U.S. DOE defines a microgrid as a "group of interconnected loads and distributed energy resources (DER) with clearly defined electrical boundaries that acts as a single controllable entity with respect to the grid [and can] connect and disconnect from the grid to enable it to operate in both grid connected and island mode."

⁷ See *NFPA 70-2017 NEC for installation requirements of premises wiring systems related to microgrids*.

2. Additional site-specific requirements may be indicated once the supply voltage, service arrangement, location, and generation purpose is determined, where such Customer proposed purpose can be either:
 - peak shaving,⁸
 - net energy metering for solar, wind, anaerobic digestion, small hydroelectric, or agricultural or other projects in accordance with the Company's net-metering tariff, RIPUC 2178,
 - Renewable Energy Growth (REGrowth Program) according to RIPUC 2152-C (for Non-Residential Customers), or RIPUC 2151-C (for Residential Customers), or
 - export energy for a QF with an agreement for sales⁹ all according to the Company's tariff provisions.
3. For new electric service or modifications to the electric service connection to accommodate the Customer's DER system, refer to the Company's latest revision of ESB No. 750, Specifications for Electrical Installations. The Customer will be responsible for any permitting and conformance to the latest revision of all local, state and federal codes and national standards that apply. For example,
 - a. Under RI and municipal building code requirements the Customer will need to provide evidence of electrical inspection approval from their local municipal code enforcement agency.
 - b. The Customer will also be responsible for any additional costs associated with work completed by another entity (such as Telco set poles). The Customer should be aware that project construction schedules can be severely impacted by this other work.
4. When considering a DER interconnection arrangement, an R.I.P.U.C. 2180 Exhibit A or B application is submitted to the Company's Distributed Generation Services department.
5. Any subsequent sale of an On-Site Generator (OSG) facility covered by the requirements of the RI SCDG of the original retail Customer's facility will require the new owner to establish a separate interconnection agreement (R.I.P.U.C. 2180 Exhibit G and/or H) for the generation and to comply with these parallel generation requirements.
6. Refer to:
 - The steps to install distributed generation in Rhode Island as specified in the RI SCDG; see Section 3.0 of R.I.P.U.C. 2180 https://www9.nationalgridus.com/non_html/RI_DG_Interconnection_Tariff.pdf,
 - The Company's Distributed Generation Services **electronic mail address** as follows for inquiries: Distributed.Generation@nationalgrid.com, and
 - The Company's (www.nationalgridus.com) "Distributed Generation" web site at http://www.nationalgridus.com/narragansett/home/energyeff/4_interconnect.asp for information and forms listed below (from R.I.P.U.C. 2180 https://www9.nationalgridus.com/non_html/RI_DG_Interconnection_Tariff.pdf) when making an application with the Company:
 - Simplified Process application form and service agreement ([Exhibit A](#))
 - Generating Facility Expedited/Standard Pre-Application Report Form ([Exhibit B](#))
 - Expedited and Standard Process application form ([Exhibit C](#))

⁸ Peak shaving generation is Customer-owned generation operated in parallel with the Company to reduce a Customer's electrical demand. Unlike net metering, peak shaving generation is not permitted to flow into the utility supply system upstream of the billing meter and will require the installation of protection devices to limit such power export onto the Company's EPS. The Company's revenue metering is detented in this case to prevent reverse billing meter registration.

⁹ An Agreement for Sales of Export Energy for a QF under a RI SCDG application may be made per the Company's R.I.P.U.C. 2098 electric tariff and is a Power Purchase Agreement.

- Supplemental Review Agreement (for those projects which have failed one or more screens in the Expedited Process) (Exhibit D)
 - Feasibility Study Agreement (Exhibit E)
 - Impact Study Agreement or Impact Study for Renewable DG (ISR DG) Agreement under the Standard Process (Exhibit F)
 - Detailed Study Agreement (for the more detailed study under the Standard Process which requires substantial System Modifications) (Exhibit G)
 - [Schedule B](#) Additional Information Required for Net Metering service
 - Interconnection Service Agreement (Exhibit H)
 - Agreement between the Company and the Company's Retail Customer ([Exhibit I](#))
 - The following Independent System Operator-New England (ISO-NE) requirements apply under this bulletin:
 - DER projects 60 kW or larger that will export power require asset registration by the Company's Customer Energy Integration (CEI) department to ISO-NE.
 - DER projects greater than 1 MW but less than 5 MW will require a notification by the Company's CEI department to ISO-NE via Attachment 4 under ISO-NE Planning Procedure (PP) 5-1.
 - DER projects 5 MW and greater will require a review of transmission system impacts and a Proposed Plan Application (PPA) filed with ISO-NE. Refer to ISO-NE PP 5-1.
7. The application process and attendant services are offered by the Company on a non-discriminatory basis to any Customer. As part of the process, the Company may identify the need for detailed engineering studies, EPS upgrades and additional protection requirements. As allowed by the Rhode Island PUC, the costs of the detailed study and upgrades are the responsibility of the Customer. If the Customer makes significant changes in the design or scheduling of their DER project, then any previous information furnished by the Company to the Customer is subject to review and possible change, which may cause a delay in service.
8. The following website contains the Company's application of the RI SCDG net metering rules: http://www.nationalgridus.com/narragansett/home/energyeff/4_net-mtr.asp.

5.4 Special System Considerations

The Company will identify in the DER impact study any systems that may require special considerations including but not limited to those in this section.

5.4.1 Secondary Grid and Spot Network Areas

1. When applying for a DER interconnection within the Company's secondary area network and secondary spot network EPS located in the downtown districts of Pawtucket and Providence in Rhode Island, DER installations on distribution secondary network systems may require a study to be undertaken to ensure the DER facility does not degrade the reliability, power quality, safety, or operation of the Company's network system. For these areas, the study may be required regardless of DER size, type, or complexity. Therefore, customers in the downtown districts of Pawtucket and Providence **should check the National Grid Website: "Area Network Maps"** [https://www9.nationalgridus.com/narragansett/home/energyeff/network/5_area_networkmaps.asp]. **If that street location is highlighted in red (or near) the red line, then contact the Company at (Distributed.Generation@nationalgrid.com)** to determine if the proposed location is served by a distribution secondary network system. This should be done while the project is still in the planning stage, and certainly before purchasing equipment or beginning installation. The Company's CEI department will review the Customer's plans and discuss options with the Customer. Refer to attached [Exhibit 2](#) for area maps locating the Company's secondary network service areas.

2. Unlike radial distribution systems that deliver power to each customer in a single path from source to load, underground secondary area network systems deliver power to each customer through a complex and integrated system of multiple transformers and underground cables that are connected and operate in parallel; refer to attached **Exhibit 3** for more information.
 1. Connecting customer DER to the low voltage secondary networks can cause the power flow on network feeders to shift (i.e., reverse) causing network protectors within the network system to trip open. The Company's network system protection is designed without time delay. Synchronous generators are not permitted to interconnect to the Company's secondary voltage network systems. Small induction and inverter-based generators are considered on the secondary voltage network systems on a case-by-case basis.
 2. Spot networks are similar to area networks except they serve a single premise. Connection of DER systems on the spot networks are only permitted if the secondary bus is energized by more than 50% of the number of installed network protectors as required by the current version of the IEEE Std. 1547.
 3. As a result, the connection of customer DER facilities on networks **(i)** poses some issues for the Company to maintain adequate voltage and worker safety and **(ii)** has the potential to cause the power flow on network feeders to shift (i.e., reverse) causing network protectors within the network grid to trip open. Therefore, to ensure network safety and reliability additional information will be required for the Company's engineering analysis such as:
 - Customer's existing¹⁰ or proposed electric demand profile showing minimum load during peak generation time,
 - Customer's expected generation profile shown for a 24-hour period and typical seven (7)-day duration based on nameplate generation rating, and
 - Customer's complete electric service single-line diagram showing the configuration of the proposed generation and other metered tenants, if any, up to the service point supplied by the Company's secondary network EPS.

5.4.2 Less than 5kV Distribution Systems

Due to the existing limitations and company requirements for 4kV systems, DER interconnections equal to or greater than 150kW that are proposed to interconnect to the 4kV EPS require a System Impact Study. Any DER customers proposing to interconnect greater than 300 KVA, are no longer be permitted to interconnect to the 4 kV system.

5.4.3 High Tension (HT) and Underground Systems

The National Grid high tension HT system is an impedance grounded, non-effectively grounded distribution system and has a mix of complex relaying schemes including directional and pilot wire protection schemes. Other portions of National Grid's system are underground (non-network) systems and have similar complexities that may require impact study regardless of facility size. All interconnections to these systems shall be non-effectively grounded with zero sequence overvoltage (59N) ground fault protection, which commonly requires external relaying – requirements for which are determined in the impact study. Interconnections of all sizes proposed to connect to these systems may require an impact study.

¹⁰ In addition, the Company may need to install recording equipment at all metered electricity users to determine the total demand of the building's network service when obtaining the service connection's electric demand profile. The cost to the Customer will be according to the Company's electric customer load survey flat rate and charged in accordance with the terms of the RI SCDG.

5.5 Interconnection Charges

Customers shall be subject to charges for interconnection costs. To permit interconnected operations with a Customer, the Company may incur costs in excess of those it would have incurred had the Customer taken firm service. These costs, called interconnection costs, are directly related to the installation of those facilities the Company deems necessary for interconnection. They include initial engineering evaluations, purchase and installation of additional switching, transmission, distribution, and communication equipment at Company's facilities, safety provisions, engineering and administration. These costs shall be paid in full by the Customer prior to commencement of service in accordance with the Company's tariffs, R.I.P.U.C. 2180 and 2130. For typical Company interconnection cost items expected in DER projects that will be defined in either an Impact or a Detailed Study, see the following two tables. Tables are not intended to be all inclusive. Costs will be determined according to the Company's electric tariff and the RI SCDG.

Table 5.5-1: DER Projects where no EPS upgrades are expected

Item No.	Typical Company Support Activities Attributed to Customer's Project Requiring Charges to the Customer)
1	Engineering acceptance review of Customer's construction design submittals where the Company has mutual interest such as service connection facilities, meter mounting provisions, Company-designated protective devices and control schemes according to the Company's ESB 750 series.
2	Revenue metering equipment changes/additions.
3	Field audit of Customer installation to accepted design.
4	Field compliance verification - witness tests of Customer protective devices coordinating with the Company Distribution EPS.
5	CEI Project Management

Table 5.5-2: Complex DER Projects

Item No.	Typical Company Support Activities Attributed to Customer's Project Requiring Charges to the Customer)
1	Company Distribution EPS upgrades (e.g., Current Limiting Fuses, Primary Conductors, Line Reclosers, Switches, Voltage Regulators, Capacitors, etc.) as a result of DER impact.
2	Where Local EPS anti-islanding protection is required, Direct Transfer Trip (DTT) transmit addition to Distribution EPS substation feeder breaker (and/or Line Recloser) for DER impact on distribution feeder.
3	Where Company-provided Radio Communications can be applied, additions to support DTT equipment at Distribution EPS substation feeder breaker (and/or Line Recloser) for DER impact on distribution feeder.
4	Where Local EPS feeder selectivity may require prompt control measures for DER impact on distribution feeder operations, EMS-RTU (status & control) addition at the DER facility.
5	Service Connection modifications and additions for DER impact on the Company Distribution EPS.
6	Revenue metering equipment changes/additions.
7	Engineering acceptance review of Customer's construction design submittals where the Company has mutual interest such as service connection facilities, meter mounting provisions, Company-designated protective devices and control schemes (e.g., DTT receive package installation at DER) according to the Company's ESB 750 series.
8	Field audit of Customer installation to accepted design.
9	Field compliance verification - witness tests of Customer protective devices coordinating with the Company Distribution EPS.
10	Project Management (CEI, Distr. Line, Distr. Station, etc.)

6.0 Potential Issues Related to Interconnection

6.1 General Considerations

1. Customer generation connected to the distribution system can cause a variety of system impacts including steady state and transient voltage changes, harmonic distortion, and increased fault current levels. Parallel generation systems, which located individually on higher capacity feeders may not cause very serious impacts, can, on weaker circuits, in aggregation or in special cases (such as lightly loaded networks), significantly impact the Company's distribution EPS.
2. An Impact Study and a Detailed Study in some cases is needed to identify the severity of system impacts and the upgrades needed to avoid problems on the Company EPS.

Typically, an Impact or Detailed Study will be performed by the Company to determine if the proposed generation on the circuit results in any relay coordination, fault current, and/or voltage regulation problems.

3. There is a wide range of potential issues associated with the interconnection of DER facilities to the Company Distribution EPS including, but not limited to:
 - a. Impact on step voltage regulation equipment
 - b. Increased fault duty on Company and Customer protective devices and equipment
 - c. Interference with the operation of protection systems
 - d. Harmonic distortion contributions
 - e. Voltage flicker
 - f. Ground fault over voltage
 - g. Risk of islanding
 - h. System restoration
 - i. Power system stability
 - j. System reinforcement
 - k. Metering
 - l. Arc Flash
4. It is important to scrutinize the interconnection of Customer DER facilities to the Company EPS so that any negative impacts to the Company EPS performance can be avoided without degradation of EPS safety and reliability. It is the intent of any Company study in accordance with the RI SCDG requirements when applicable to avoid negative power system impacts by identifying the particular type of impact that will occur and determining the required equipment upgrades that can be installed to mitigate the issue(s).
5. In general, DG facilities connected to various locations on the radial distribution EPS (see Illustration 6.1.5-1) are initially evaluated for the maximum possible DER capacity under ideal situations that can be installed on the Company's EPS through technical screens. Where initial technical screens identify concerns on the Company's EPS, site specific system studies (e.g., available short circuit current contributions, minimum network loading in light loading seasons, voltage regulator interactions, etc.) will be required and will identify the interconnection requirements.

Illustration 6.1.5-1: Typical DG Installation Areas on Radial Distribution Feeders

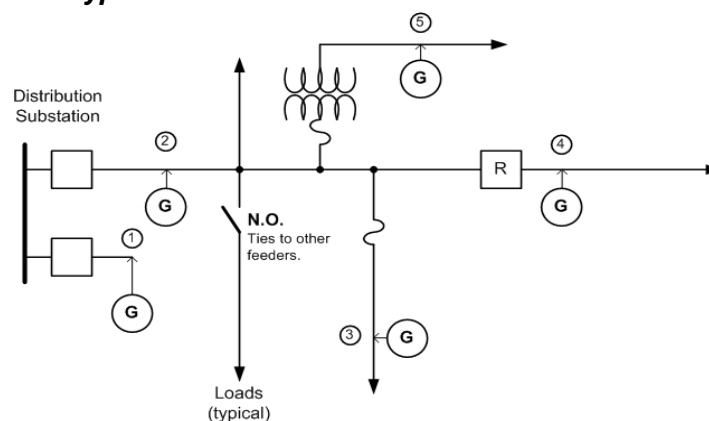

“O” - DG Interconnection Location Point on Feeder

1. Express (dedicated) radial feeder
2. Feeder Main
3. Feeder Branch protected by fuse
4. Sectionalized Feeder Main
5. Feeder Branch protected by fuse with ratio transformer

6. DER saturation, such that it becomes technically infeasible to operate on the distribution feeder or line section becomes problematic when multiple proposed projects or additional proposed projects are submitted in excess of the designed capacity of major EPS infrastructure. The Company will identify DER saturation in screening and feasibility reviews and in the results of impact studies for DER applications. Studies will be more complex and accommodating interconnections will likely require more involved infrastructure development, costs, and duration to construct.
 1. The EPS substation bus voltage regulation, transformer capacity, and high voltage side protection may be impacted by large DER systems and the Company may specify interconnection to a higher voltage EPS, which allows for continued growth of small DER on the Company's Distribution EPS (e.g. residential solar).
 2. On single-phase radial distribution systems, generator interconnections with aggregate generator nameplate ratings over 50 kVA may require three-phase service and will be determined by the Company on a case-by-case basis.
7. The Company's distribution substations are subject to fault duty limitations. Adding generation to the Company Distribution EPS increases the amount of fault current imposed on the substations and equipment on the feeder(s). Exceeding the fault duties of equipment and devices at the substation(s) and on the feeder(s) as a result of DER facilities will not be permitted. Where the equipment fault duty ratings have been reached or exceeded, alternate methods of interconnection shall be explored or equipment shall be replaced at the expense of the Customer with comparable equipment of the appropriate withstand and/or AIC rating.
8. Normally, one service is provided to the customer according to the Company's Electric Tariff, **RIPUC 2098**. However, under specified conditions, multiple service facilities may be supplied to the Customer from a Company Distribution EPS. The interconnection of multiple services shall be specified by the Company within the Company's operating practices and electric service requirements.¹¹

6.2 Significant EPS Considerations

6.2.1 Direct Transfer Trip

IEEE 1547 requires any DER on a distribution feeder to detect and be tripped offline within two (2) seconds upon formation of an island from the area EPS. *An island is a condition in which a portion of an area EPS is energized solely by one or more Local DERs while it is electrically separated from the rest of the area EPS.* There are some cases where a DER's on-site equipment (such as voltage and frequency relaying or islanding detection) cannot reliably detect utility islands. Where the Company determines that a significant risk of islanding exists, direct transfer trip (DTT) may be required. DTT typically requires utility substation modifications to send a signal to trip the DER facility offline when the substation breaker opens. This also typically requires the Customer to lease a communication medium between the substation and the DER facility, as well as install a receiver and tripping device in their facility. DTT has inherent high costs and physical limitations associated with equipment installation due to the typical leased telecommunication line requirement at the EPS source and at the generator(s), as well as required utility substation modifications. The initial and recurring costs for DTT are at the expense of the Interconnecting Customer. See section 7.6.12 for more detail on when DTT may be required, which includes but is not limited to islanding

6.2.2 Transmission Ground Fault Detection

The addition of generation sources to distribution feeders can result in the backfeeding of the substation transformers, effectively turning a station designed for load into a generation step-up transformer. The Company's most common

¹¹ See Section 3 in the Company's ESB750 for more information on multiple service requests.

distribution substation transformer has a delta connection on the transmission side and a wye-grounded connection on the distribution side. Due to the transformer's configuration,¹² it cannot contribute zero sequence ground fault current to single line to ground faults on a transmission line, and the voltage on the unfaulted phases rises significantly and rapidly. These overvoltages have the potential to exceed insulation levels of the station and transmission line equipment, and maximum continuous operating voltage of surge arresters. This situation can also leave transmission ground faults energized by the distribution-connected DER. Zero sequence voltage protection (commonly referred to as "3V₀") on the primary side of the transformer is required in order to detect these overvoltage conditions. This 3V₀ protection will disconnect the generation from the substation transformer, and stop the generation and transformer from contributing to the transmission-side overvoltage condition.

If the Company determines there is a likelihood of a zero sequence overvoltage event, transmission ground fault detection equipment and substation modifications may be required.

¹² *There may be other transformer configurations for which zero sequence continuity is broken and/or the DER is unable to reliably detect and trip offline for transmission ground faults. The Company determines when and which type of transmission ground fault detection is required based on the substation configuration on a case-by-case basis.*

Illustration 6.2.2-1: Simple One Line for Transmission Ground Faults for Typical Substation Transformer Configuration

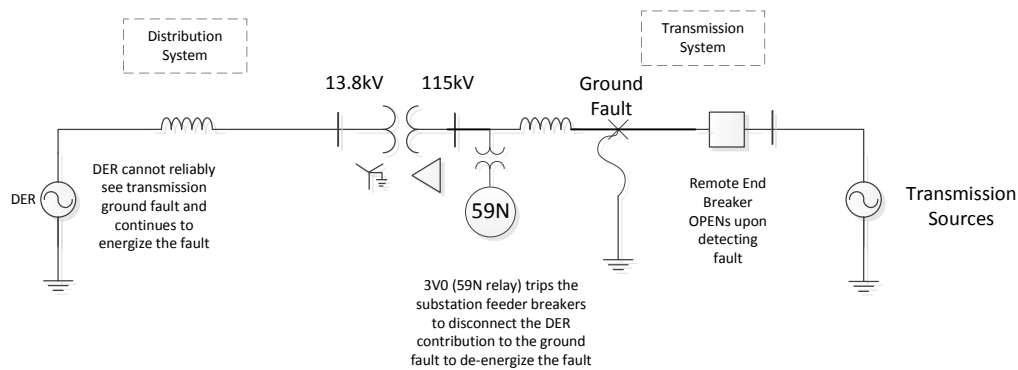

Illustration 6.2.2-1 shows an example transformer configuration for which it is difficult for distribution-connected DERs to detect and trip for transmission ground faults. Where the DER can contribute to this condition without tripping on the 88% undervoltage trip point, $3V_0$ may be required to be installed at the substation. Three voltage sensors (typically coupling capacitor voltage transformers (CCVT), are connected to the transmission side of the utility substation transformer. These voltage sensors are wired to a 59N relay (“ $3V_0$ ” or zero sequence overvoltage function), which trips the DER offline via utility breakers in the substation. This helps de-energize the ground fault from all sources. (Not all details or configurations are shown. Some substations may require protection for detecting transmission ground faults other than $3V_0$, such as scheme modifications, transformer replacement, or teleprotection systems). Customers should be aware that these modifications to the Company’s substations require significant cost and time to install. The cost and time requirements are provided in the impact study according to the RI SCDG and the Company’s Electric Tariff when performed for the Interconnecting Customer.

7.0 General Design and Operating Requirements

From the perspective of interconnection, there are three main types of customer generation systems that interface to the Company’s Distribution EPS. These include:

- Induction Generators
- Static Power Converters (inverter-based)
- Synchronous Generators

Each type has its own specific characteristics regarding synchronization equipment, protective functions, starting practices, and electrical operating behavior. There may also be additional specific requirements that may be identified as part of any impact study that is performed for a specific DER system and/or location as part of any Impact or Detailed Study that is performed for a specific location. For the purposes of this bulletin, any reference to DER ratings herein refers to the nameplate rating of the generation. Equipment nameplates shall meet ANSI standards.

- For inverter based generation, this shall refer to the nameplate rating of the inverter(s). De-rating of inverter-based DER shall only be considered if the equipment is provided by the Customer’s manufacturer with a permanent means of reducing the rated output, and so marked with an equipment nameplate stating the de-rated output.
- For rotating machines, this shall refer to the nameplate rating of the generator (as opposed to the nameplate rating of the generator-set). De-rating of rotating machine generators by their prime mover capabilities shall not be permitted.
- Equipment nameplates shall meet ANSI standards. De-rating of inverter based DER shall only be considered if the equipment is provided by the Customer’s generator manufacturer with a permanent means of reducing the rated output, and provided with an equipment

nameplate stating the de-rated output. De-rating of DER equipment shall be evaluated for acceptance on a case-by-case basis, with consideration given to specific project conditions, and will be accepted at the discretion of the Company.

For facility or campus-style microgrid connections, DER interconnection equipment, protective systems and microgrid controllers connected at the PCC to the Company's EPS are to be designed and operated according to the Company's requirements in this bulletin as well as to applicable codes and industry standards. Facility or campus-style microgrids may be permitted to automatically trip their PCC isolation device in order to island and serve the premises load; however, this device is required to be blocked from closing until authorized to do so by the Company. The control scheme that will disconnect and reconnect the facility or campus-style microgrid from the Company's EPS must be reviewed and approved by the Company through the RI SCDG process and is subject to witness testing and/or periodic testing as necessary. These situations will require that specific operating protocols to ensure that customer safety and the overall EPS safety and reliability are not in any way compromised.

7.1 General Criteria

The interconnection of all DER systems in parallel with the Company's EPS requires safeguards for synchronization and back feed situations in accordance with the RI SCDG. Each specific connection must be studied with respect to size, type, and the nature of the Company's Distribution EPS at the POI. Only the results of a specific study can indicate the suitability of a given generator connection to the Company's Distribution EPS and its possible economic viability. See the RI SCDG for detailed requirements.

7.1.1 Delivery Voltage

The Company will designate the type of service and delivery voltage based on the location of the Customer and the size and character of its proposed DER.

7.1.2 Single Phase

Single phase DER system connections to the Company's EPS circuits under 600 volts present power quality and phase balance challenges. Single phase connections shall have these minimum characteristics:

- Nameplate rating of a single generator or group of generators equal to or less than 50 kVA unless otherwise specified by the Company on a case-by-case basis.
- Configured as a three-wire, line-to-line with neutral, or line-to-neutral with adequate load balance.
- A dedicated service lateral with a dedicated transformer, when required by the Company.

7.1.3 Three Phase

Other than permissible single phase connections, three phase connections are required. The aggregated nameplate rating of all DER systems operating in parallel with the Company's EPS on the premise equal to or greater than 5 MW according to the RI SCDG for facilities, or group of facilities, have specific requirements under ISO-NE Operating Procedures No. 14 and No. 18. Refer to ESB 756 Appendix A for additional information in these cases and where wholesale DER connections are proposed.

7.1.4 Phase Balance and Voltage Tolerance

1. The Customer's DER facility shall permit equal current in each phase conductor at the service point or PCC. Voltage unbalance resulting from unbalanced currents shall not exceed 2% and shall not cause objectionable effects upon or interfere with the operation of the Company's facilities and service to others. This criterion shall be met with and without generation.
2. The interconnection of the DER facility shall not affect the Company's nominal voltage delivery at the PCC by greater than 3%.

7.1.5 Neutral Stabilization, Ground Faults, and Grounding

Multi-grounded distribution area EPS:

1. An effectively grounded system with respect to the Company's EPS must be provided to ensure neutral stability, facilitate ground fault detection, and avoid distribution circuit over voltage during accidental isolation of the Company's area EPS from the Company's main system. This may require an additional ground source. see Section 7.3 for acceptable effective grounding options.
2. Contributing to ground faults on the Company's distribution EPS can desensitize the relays at the Company's substation. The effects of such grounding on the Company's ground-relay sensitivity shall be limited. The Company requires ground fault protection on any system that can be a generation source and to protect transformers that can be paralleled and supplied from two sources. When generator tripping is needed to sense ground faults on the Company's distribution EPS:
 - The winding arrangement of the Customer's DER facility transformer and the generator winding shall be such that the Company's system remains effectively grounded (see Section 7.3).
 - The Company may require that the grounding impedance be limited to the highest value suitable for neutral stabilization, or to limit generator ground fault contributions. Contribution to the faults on the Company's distribution EPS can desensitize the relays upstream of the Customer's interconnection. For that reason, it is required that the Customer provide a means to install a grounding reactor/resistor within their facility to limit the ground fault current. Where possible, this shall be limited to three times the generator rating and limit the rise of ground fault current at the point on the high voltage (primary) level nearest the proposed service point by no more than 10%. The grounding reactor/resistor shall not violate the effectively grounded system requirements. The impedance of the grounding reactor/resistor will be specified by the Company. If the 10% criterion is not met with the grounding impedance, other methods, upon Company acceptance may be required by the Customer to mitigate the increase in fault current.
3. As a minimum, the Customer's DER system equipment shall be grounded in accordance with the latest requirements of the NEC. For specific installations, refer to the applicable sections of this document and the Company's ESB 750.
4. Distribution circuits may have unbalanced loads (i.e. single phase loads) which result in neutral currents on equipment connected to multi-grounded circuits. Customers installing grounding equipment (i.e. grounding reactors, grounding transformers) are encouraged to consider this unbalance current when designing neutral-connected equipment where there is no transformer isolation from the Company's EPS. The Company recommends the Customer consider a minimum 100A continuous current rating (or the actual unbalance current, whichever is greater) for 15kV class-connected grounding reactors, and similar equipment parameters for other voltages.

If the Customer is permitted to interconnect through an un-grounded source, a 3V₀ scheme may be required on the primary (utility) side of the accepted ungrounded source (ungrounded transformer serving the DER system, or generator as applicable) (see Figure 5) supplying the DER system. Refer to Section 7.3.1 for further discussion on service transformer requirements. Directly-connected ungrounded generators, where accepted, may require a 3V₀ scheme in a location appropriate for detecting utility-side ground faults.

It is the Customer's responsibility to detect and trip the facility for ground faults on the Company's distribution EPS – the Customer shall not rely on Company equipment for the protection of customer equipment (e.g. grounding transformers).

7.2 Service Equipment and Revenue Metering

7.2.1 Service Equipment Requirements

1. The Customer shall provide service entrance equipment as a part of their installation; see the Company's ESB 750. The Customer's service equipment shall be rated, at a minimum,

for the maximum fault current available from the Company EPS and their own contribution from the generator(s), motors, etc.

2. Marking: The Customer shall install and maintain clearly marked permanent labels in accordance with the NEC, RIPUC 2180, and the Company's applicable ESB series requirements. All Utility required marking shall be preprinted or engraved (no hand marking), have a minimum 5-year warranty for indoor or sheltered applications and have a minimum of 25-year warranty for use in outdoor applications. Labels shall be replaced when they no longer meet the legibility requirements of ANSI Z535.4. Labels shall be UL969 compliant. Materials used shall be weather resistant, UV stabilized and suitable for the environment where it is installed. Labels may be of engraved plastic, metallic foil, or polymer plastic mechanically or adhesive applied. For labels using adhesive, ultra-high strength bond adhesive shall be required. Data sheets shall be provided to indicate compliance with labeling requirements.

Exception: Residential installations \leq 25kW with feed-through type meters may have labels with a minimum 5-year warranty regardless of location.

In addition to NEC required marking, the following Utility requirements apply:

The utility meter enclosure shall be labeled with the following: "WARNING: MULTIPLE POWER SOURCES" or "WARNING: DUAL POWER SOURCE" as applicable.

- The utility meter sockets shall be labeled as follows¹³, where applicable:
 - Utility Service Meter
 - Utility [DER type] Sub-Meter, where "DER Type" shall be designated by generation type as follows:
 - "PV Generation" or other type Generation as required per Tariff, or
 - Storage.
- The Interconnecting Customer's AC utility disconnect switch shall be labeled "AC DISCONNECT".
- If the AC utility disconnect switch is not adjacent to the meter and/or PCC, the Interconnecting Customer shall provide marking as to the location of the switch.
- All Interconnecting Customer-Owned meters shall be labeled "CUSTOMER-OWNED METER"

3. For large Customers with aggregate generation equal to or greater than 500 kW, refer to the typical primary overhead service configuration requirements in Exhibit 6.

4. For situations where a higher voltage service connection is required, refer to the Company's ESB 752, 753, or 758 as applicable.

13 Some installation may require multiple of the above meters depending on the incentive mechanism. Where multiple meters exist of the same DER type, each meter shall be labeled (i.e. Utility PV Generation Meter 1, Utility PV Generation Meter 2, etc...)

7.2.2 Company Revenue Metering Requirements

1. The Company will specify the location and arrangement of all equipment required for the revenue metering of the Customer's service and DER facility as well as the monitoring of compliance with all applicable laws, regulations, interconnection agreements, and power purchase agreements. Reference the Company's ESB 750, Section 7 for additional information and requirements. The Company's net metering tariff, R.I.P.U.C. 2178, which describes qualifications for net energy metering. Where net metering does not apply, the Company's revenue metering will have multiple channels for power delivered and received for power purchase agreements (PPA) or be detented¹⁴ to prevent reverse billing meter registration. When applicable, credit metering will be installed if arrangements have been made for energy sales to the Company.
2. The Customers may be required to provide a telecommunications line to each Company-owned revenue meter location. The telecommunication line would be required only in the event a cellular signal is not present for standard revenue meter reporting. The telephone line shall be capable of direct inward dial without human intervention or interference from other devices such as fax machines, etc. The Company will make the final determination of any Customer proposed alternate telecommunications service for Company-owned revenue metering, if any, for the specific Customer's DER system installation.
3. For fully rated meter installation, the DER source shall terminate to the lugs at the bottom of the meter socket. The Utility side connection shall terminate to the lugs at the top of the meter socket.

7.2.3 Company Revenue Metering Requirements (RI REGrowth Program)

RI REGrowth DER projects require a separate meter for DER metering such that two meters are normally installed including the supply meter at each location at the IC's expense. The service supply to the two meters can be one combined service connected to a multi-gang meter socket and then split for the final meter connections; see the Company's ESB 750 (<https://www.nationalgridus.com/ProNet/Technical-Resources/Electric-Specifications>).

The installation of a single service from the weatherhead to a junction box mounted on the side of the house, which would subsequently serve individual meter sockets is not acceptable. Bifurcation of the service for the purposes of serving multiple meters related to RI REGrowth is only acceptable at the weatherhead.

Refer to illustration 7.2.3-1 for this meter location and installation and note:

- $\leq 25\text{kW}$, IC installs 2-gang meter socket trough at service location accessible for the Company's AMR meters (standard for load, net type for DG).
- $> 25\text{kW}$, IC installs metering provisions at service location for the Company's wireless communications meters (detent for load, bi-directional for DG).

Illustration 7.2.3-1 Typical RI REGrowth Metered Service

¹⁴ "Detented metering" is measuring and registering power flow in a single direction by either mechanical, or electronic, or programming means in a revenue meter.

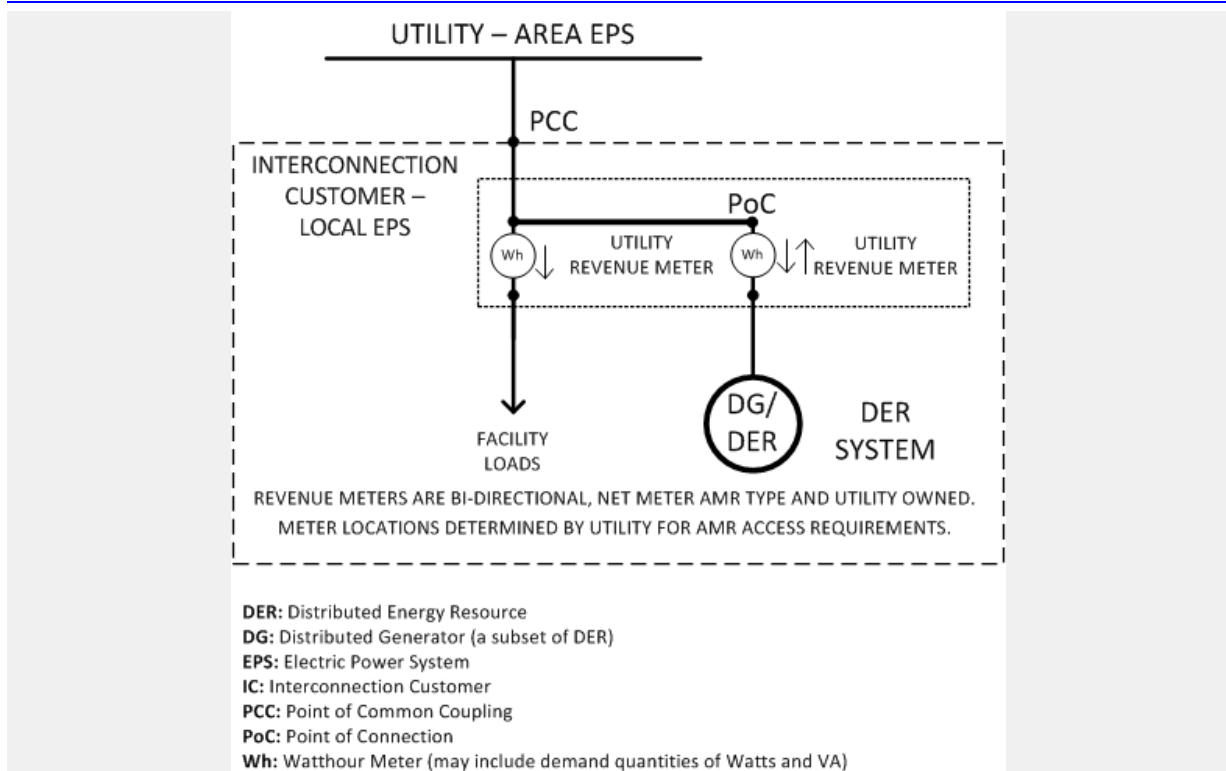

7.3 Transformer

7.3.1 Secondary Served Customers

Where the Company provides secondary service, the Company's transformer is an equipment standard for service delivery voltages; see Section 3 in **ESB 750**. The maximum transformer size the Company will supply for a new secondary connected DER connection is 300 kVA where the non-DER premises electricity use is 300 kVA or less. Non-standard transformers will not be provided by the Company. The Company will determine when dedicated services and a dedicated transformer are required in order to reduce the impact on other adjacent customers. The need for a dedicated transformer(s) may be determined at any point in the Customer's life cycle. If a dedicated transformer(s) is required, the Customer will be advised by the Company in writing. The cost of the transformer(s) will be the responsibility of the Customer according to R.I.P.U.C. 2130 and as permitted by the **RI SCDG**. DER facilities proposed on the customer side of an existing Company-owned transformer may require the existing transformer service to be replaced under the following typical conditions, although not all inclusive:

1. DER exceeds the Company's transformer nameplate ratings
2. Interconnection of DER to the customer side of the transformer creates undesirable effects on the company system.
3. Transformer is a non-standard design no longer provided by the Company's standard (see ESB 750 for standard service voltages) to meet the power quality, safety, and/or reliability to the individual Customer, or the EPS.
4. Existing transformer configuration is such that an additional primary side protection scheme is necessary for the DER facility to detect and trip the generation source for faults on the Company's EPS that would require the Customer to have primary service.

7.3.2 Primary and Higher Voltage Served Customers

The Company reserves the right to specify the winding connections for the Customer's interconnection transformer between the Company's delivery point and the Customer's DER facility output terminals as well as whether it is to be grounded or ungrounded. The Customer

shall provide their interconnection transformer's specifications and ratings for the Company's review and acceptance in the impact and detailed studies.

7.3.2.1 Effectively Grounded, Four-wire Multi-grounded 3-phase Wye EPS:

To avoid over voltage on the distribution EPS, the Company's policy requires that any DER facility 500 kW and above connected to a four wire distribution feeder to provide an effectively grounded system with respect to the Company's EPS. Refer to Section 7.1.4 for specific grounding requirements.

The Company requires that the Customer select their interface transformer's winding configurations so that the DER system is interconnected effectively grounded. The Customer's DER facility shall be designed such that the DER cannot connect to the Company EPS without the means of effective grounding in service. In all instances, when the means of effective grounding is out of service or disconnected from the system, the DER site shall be disconnected from the Company EPS.

Aggregate DER below 500 kW in a Customer's facility may be permitted to utilize an ungrounded interconnection (e.g. primary delta - secondary wye grounded or primary wye grounded – secondary wye grounded transformer with an ungrounded source). The Company reserves the right to require an effectively grounded source for generation 250 kW and above depending on DER saturation and other conditions on individual distribution EPS feeders. Effective grounding may be accomplished with the following configurations:

1. A wye-grounded to wye-grounded transformer with a grounded generator source. A neutral grounding reactor between generator neutral and ground may be required in event the generator's contribution to faults on the Company's EPS results in undesirable fault current values. See section 7.1.5.
2. A wye-grounded connected primary winding with a fully insulated neutral and a delta connected secondary winding. The insulated neutral is to establish provisions for the addition of a grounding reactor or grounding resistor in the event the generator's contribution to faults on the Company's EPS results in undesirable fault current values. See section 7.1.5.
3. A wye-grounded to wye-grounded transformer with an associated grounding transformer.
4. A delta primary winding with a primary side grounding transformer and having any secondary configuration.
5. A wye-grounded primary with wye-ungrounded secondary with a primary side grounding transformer.
6. A wye-ungrounded primary with wye-grounded or wye-ungrounded secondary with a primary side grounding transformer.

7.3.2.2 Not Effectively Grounded, Three-wire 3-phase EPS:

On three-phase Company EPS circuits other than effectively grounded, only the connection of ungrounded primary interface transformers shall be permitted. A delta primary is normally required.

7.4 Manual Generator Disconnecting Means

The Customer's DER facility shall have an electrical load break disconnect switch accessible at all times to the Company to electrically isolate the Company's distribution EPS from the customer's DER system. The Customer shall provide direct 24/7 unencumbered access to the disconnecting switch to allow Company personnel to operate the disconnecting switch and apply protective grounds as needed, without the need to contact the Customer. The Company will make efforts whenever possible to notify the Customer should the DER facility need to be de-activated, however the Company reserves the right to operate the DER facility's disconnect directly in emergency situations in accordance with Section 7 of R.I.P.U.C. 2180.

The Customer shall provide contact information for Customer personnel that can be reached 24/7, should complications arise with access to the Customer's equipment. Should there be any complications with Company access to the DER disconnecting means, the Company reserves the right to disconnect the Customer's service in its entirety via the next upstream Company owned disconnecting means in accordance with Section 7 of R.I.P.U.C. 2180.

The disconnecting means shall have the following characteristics:

1. **Rating:** Disconnecting means shall be rated to interrupt the maximum generator output; meet applicable (UL), (ANSI), and IEEE standards; and shall be installed to meet the NEC and all applicable local, state, and federal codes.
2. **Arrangement:** The disconnect switch shall be installed to have the line connection (i.e., jaw side) of the switch connected to the utility source. Disconnects with more than one current carrying conductor shall be gang operated. It shall be capable of being grounded on the Company side. The grounding means must be compartmentalized such that the location where the ground is applied is completely barricaded from any live parts.
3. **Type:**
 1. The type of disconnecting means for all DER is subject to Company approval
 2. For DER systems that are connected directly to the area EPS requiring a manual disconnecting means at the PCC that can be opened for isolation, the device shall be a gang-operated, blade-type switch. Pull-out switches or blocks are not permitted for this application. In accordance with the Company's safety rules and practices, this isolation device must be used to establish a visually open, working clearance boundary when performing maintenance and repair work. The visual open must be observable without opening the equipment.
 3. For DER systems connected directly to a Customer's building distribution system downstream of the PCC requiring a manual disconnecting means for isolation of the DER, the disconnecting means may be a draw out circuit breaker, disconnect, or comparable device mutually agreed upon by the Company and the Customer. In accordance with the Company's safety rules and practices, this isolation device must be used to establish a visually open, working clearance boundary when performing maintenance and repair work. For installations above 600 V, the visual open of all three phases shall be capable of being observed without opening the equipment. Site-specific technical requirements will be considered by the Company if permitted to grant draw-out breakers with the provision for padlocking at the draw-out position, above 600 V or with a full load output of greater than 960 A, that are proposed to meet these isolation requirements. If the Company grants such use, the Customer will be required, upon the Company's request, to provide qualified operating personnel to open the draw-out circuit breaker and ensure isolation of the DER system, with such operation to be witnessed by the Company followed immediately by the Company locking the device to prevent re-energization. In an emergency or outage situation, where there is no access to the draw-out breaker or no qualified personnel, the Company may disconnect the electric service to the premise to isolate the DER system.
4. **Location:**
 1. The location of the disconnecting means shall comply with Company standards for working clearances, access road construction, vegetation management, and other similar requirement to ensure adequate access for Company personnel and equipment.
 2. The location of disconnecting means for all DER projects is subject to Company approval on a case-by-case basis, shall comply with Company standards for working clearances, access road construction, vegetation management, and other similar requirements to ensure adequate access for Company operating personnel and equipment.
5. **Access and Locks:**

1. The disconnecting means must be readily accessible at all times to the Company to electrically isolate the Company's Distribution EPS from the Customer's generator facilities. In all instances, the disconnecting means shall have provisions to be locked in the open position with space for Company and Customer padlocks.
 2. Should the disconnecting means be located behind the Customer's locked gate, double locking is required, where both the Company's and Customer's locks would be employed.
7. **Identification:** All required disconnecting means shall be identified by a permanent sign as required by the NEC and the ESB 750.

Exception:

In accordance with the **RI SCDG** and the Company's electric service requirements in ESB 750, inverter-based systems 25 kW and below are not required to have a separate manual disconnecting means if the unit has a disconnecting means integrated into the design and meets the requirements of the National Electrical Code (NEC).

For systems 25 kW and below, a disconnecting or isolation means shall be required to be located between the Company meter and the DER device to allow for Company testing of the meter socket prior to meter installation. This device may be located based on customer preference, although where this device is not accessible to the Company, this may cause delay with associated meter installation and testing.

7.5 Generator Interrupting Device Requirements

7.5.1 General

1. For any aggregate generation connected to a common feeder that is 500 kW and greater, an interconnection interrupting device such as a circuit breaker shall be installed at the Customer's site. The 500 kW criteria is intended to encompass individual sites that are comprised of multiple smaller generators, totaling 500 kW or greater. It is also intended to encompass generation located at multiple sites that total 500 kW. Due to the unique circumstances of each individual installation, the Company reserves the right to require an interrupting device if necessary. As such, interrupting devices may be required for projects below 500 kW, if the project warrants the installation. The Company may elect to waive this requirement if all Company protective and interrupting requirements are met by a Company device at the facility.
2. The generator interrupting device shall be designed to ensure the interrupting of the DER system, and its effective grounding source upon loss of interrupting device supply power, or upon loss of local power supply source.
3. When a local power supply source is utilized, generator interconnection interrupting devices shall have DC trip coils and tripping energy.
4. For primary wye grounded – secondary delta, and for primary delta interconnection transformers, the interrupting device shall be installed on the high voltage side. If there is more than one interrupting device, this requirement applies to each one individually. The interconnection interrupting device shall be capable of interrupting the current produced when the DER facility is connected out of phase with the Company's EPS.
5. The interrupting device shall be located upstream (closer to the Company's source) of the generation and any grounding transformer(s), so that it is capable of disconnecting the fault current contributions of the generation and grounding transformer.

7.5.2 Local Power Supply Requirements

When a continuous local power supply is proposed to comply with the Company's protection element operational requirements to safely remove the generation from the EPS the following conditions shall be met:

1. Failure of an uninterruptible power supply (UPS) rectifier shall not inhibit relay power supply and operation from the local power supply.
2. A fail-safe alarm contact shall be incorporated into the control trip scheme of the generator main interrupting device for loss of local power supply charge source.
3. The local power supply shall be sized to ensure successful operation of generator interrupting device upon loss of charge source. This supply shall be capable of providing all power requirements to initiate and complete the entire operating process of tripping the interconnection interrupting device.
4. The local power supply system shall be hard-wired and permanently installed. Portable cord-and-plug devices are prohibited.
5. System design calculations in accordance with IEEE standards and other industry standards as applicable shall be provided by the Customer for supply voltage, capacity specifications, and charging system provisions and are subject to the Company's review and acceptance.
6. Control circuits associated with protective relays shall be DC powered from a battery and battery charger system. The battery shall be the sole source of tripping energy. Solid state relays shall be self-powered or DC powered from a battery and battery charger system.
7. If the DER facility uses a non-latching interconnection contactor, AC powered relaying may be permitted provided the relay as well as its method of application are fail-safe, meaning that if the relay fails or if the voltage and/or frequency of its AC power source deviate from the relay's design requirements for power, the relay or a separate fail-safe power monitoring relay will immediately trip the generator by opening the coil circuit of the interconnection contactor after a maximum 2 second time delay.

7.6 Protection and Protective Equipment Requirements

The Interconnection Customer is solely responsible for the protection of their DER and premise equipment, including any customer equipment required by the Company to interconnect to the area EPS. The Interconnection Customer is also required to provide electrical equipment and relays with ranges and rating that will allow proper DER and premise relay system coordination with Company protection systems. Coordination margins and parameters will be determined by the Company.

The protection system shall be designed with interlocks and protective functions to ensure that there is proper voltage, frequency and phase angle conditions between the Company's EPS before the DER system is permitted to parallel. The Customer is responsible for voltage excursion detection and the detection of three-phase, line-to-line, and line-to-ground faults on the Company's EPS as well as faults on the Customer's system that cause overcurrent conditions on the Company's EPS.

All DER facilities shall meet performance requirements set forth by Section 4.2.3 in the RI SCDG. DER types of interconnection are categorized as either Group 1 "Facilities Qualified for Simplified Interconnection" or Group 2 "All Facilities Not Qualified for Simplified Interconnection" according to the RI SCDG. The Under Frequency relays for the Group 2 DER facilities shall not trip at frequencies higher than the curve provided for the "Eastern Interconnection Generator Tripping" in Figure 1 of the PRC-006-NPCC-1 Automatic Underfrequency Load Shedding criteria specified in the RI SCDG. The Company may specify values within the allowable ranges of IEEE 1547 subject to the limitations on voltage and frequency trip settings specified by the regional reliability coordinator that consider bulk power system impacts of affected aggregate DER capacity. Where Regional ISO voltage and frequency requirements apply, the Customer shall refer to the Company's ESB 756 Appendix A for specific requirements related to North American Electric Reliability Corporation (NERC) Protection and Control (PRC) standards.¹⁵

The DER Customer's interconnection system shall have the capability to withstand voltage and current surges in accordance with the environments defined in the latest IEEE Standard C62.41.2 or IEEE Standard C37.90.1 as applicable.

¹⁵ See <https://www.nerc.com/pa/Stand/Pages/ReliabilityStandards.aspx> and <https://www.nerc.com/pa/stand/Pages/ReliabilityStandardsUnitedStates.aspx?jurisdiction=United%20States>.

For the purpose of evaluating fault current, short circuit protection, and protective relay settings, current values are based on the full Volt-Ampere (VA) nameplate rating of the equipment, which may be greater than the kW rating of the equipment. For ESS, all protection reviews, regardless of any on-site operational limitations, are performed at the sum of the nameplate ratings of the ESS and any paired DG since fault currents are related to the full kVA nameplate ratings of the inverter(s) and/or generators used.

7.6.1 Type Tested (Certified) Equipment

Protective equipment that has been type tested and recognized under UL Standard 1741.1 by the RI SCDG for Group 1 DER facilities will be permitted. The Customer shall follow the testing requirements as outlined in the RI SCDG. Exhibit 7 attached is a guide for the Company's witness for verifying a type tested net-metered DER installation's operational compliance.

7.6.2 Non-Type tested Equipment

Protective equipment that has not been type tested per the RI SCDG and considered as Group 2 DER facilities will be permitted with the implementation of utility grade protective devices acceptable to the Company. The use of utility grade relays¹⁶ and relay redundancy is acceptable subject to prior Company review and acceptance per section 7.6.3.2.

7.6.3 Number of Relays Required

For all DER facilities equal to or above 500 kW, redundant relaying is required for the detection of Area EPS faults. Relays are considered redundant only when two utility grade relays with identical protective functions are provided.

Where relay performance may affect the operation of the Company's Distribution EPS at service voltages less than 15kV, a single utility grade microprocessor-based relay along with a Company approved scheme, where relay failure automatically trips the associated breaker(s), may be acceptable. If the Customer decides not to use redundant protection systems on their other equipment, then appropriate action such as removing equipment from service shall be taken when a piece of equipment is no longer adequately protected. The utility grade relay failure alarm shall be wired to trip and block close the Company-designated generator interrupting device. Auxiliary relays, where used, shall be fail safe and utility grade. If two utility grade relays are used to provide redundancy, whether relay failure, or being out of service, if neither relay can perform the intended protection functions the protection scheme shall trip and block close the interrupting device. The Company may elect to waive one layer of utility grade relaying if a Company PCC recloser is installed at the facility that meets the utility protection requirement.

7.6.3.1 Certified Inverter-based Energy Resource Protection Requirements

IEEE 1547 compliant and UL-1741 certified¹⁷ inverters shall be equipped with an internal active anti-islanding scheme, under voltage (27), over voltage (59), under frequency (81U) and over frequency (81O) relays. Inverter based generators shall be in compliance with the latest version of IEEE 1547. The Customer shall provide the voltage and frequency ride through capabilities as specified in IEEE 1547 Cat II in any inverters installed as part of a DER facility proposed to interconnect to the Company's EPS. The voltage regulation capabilities shall be turned OFF unless otherwise required by the Company. See section 7.8 for further inverter function requirements. Where an installation of any size, made up of individually certified DER units, is interconnected using a transformer that breaks zero sequence continuity (such as a delta high side transformer), the Company reserves the right to require utility-grade zero sequence overvoltage (59N) protection on the utility side of the transformer.

¹⁶ See definition of "utility grade" for protective device equipment in Section 4.

¹⁷ See definition for "certified" in Section 4.

7.6.3.1.1 Certified Inverter-based Energy Resources below 500 kW

If the inverter(s) are IEEE 1547 compliant and UL-1741 listed in the configuration proposed for interconnection, the internal relays are considered as the only required protection and an additional utility grade relay is not required to be installed. At the Company's sole discretion, the Company reserves the right to require a utility grade relay for certified systems above 250 kW with, at minimum, functions 27, 59, 81U/O enabled.

7.6.3.1.2 Certified Inverter-based Energy Resource equal or above 500 kW

For inverters that are IEEE 1547 compliant and UL-1741 listed in the configuration proposed for interconnection, inverter internal relay functions are considered as primary protection. The Company requires one additional utility grade relay to be installed as secondary to the utility grade protection for inverter-based DER equal or greater than 500 kW. The 27, 59, 81U/O, and 51N or 51G elements shall be activated in the utility grade protection relay. The Customer shall provide either 51G ground time overcurrent or 51N residual neutral time overcurrent as part of their ground protection requirements when meeting the NEC. On circuits where generation is permitted to connect as an ungrounded source, a 59N relay function is required to detect ground faults on the utility. Where Company-required functions are not redundant, such as overcurrent or 59N functions, refer to section 7.6.3 for fail-safe tripping requirements.

7.6.3.2 All Non-Certified Energy Resource Protection Requirements

Where Company-required functions are not redundant, such as overcurrent or 59N functions, refer to section 7.6.3 for fail-safe tripping requirements.

7.6.3.2.1 Energy Resources below 500 kW

For any non-certified generator less than 500 kW one utility grade relay is required to be installed. 27, 59, and 81 U/O at minimum shall be active in the utility grade relay. For all systems 250 kW or larger, the Company reserves the right to require redundant utility grade relay(s).

7.6.3.2.2 Energy Resources equal or above 500 kW

For any non-certified generator equal or above 500 kW, two utility grade relays are required to be installed with 27, 59, 81 U/O, and overcurrent elements for both phase and ground. On circuits where generation is permitted to connect as an ungrounded source, a 59N relay function is required to detect ground faults on the area EPS.

7.6.4 Instrument Transformers for Protective Relays

7.6.4.1 Current Transformers (CT)

CT ratios and accuracy classes shall be chosen such that secondary current is less than 5 amperes normal operation, 100 amperes under maximum fault condition and transformation errors are consistent with Company practices. For the primary wye grounded – secondary delta installations, the CTs shall be installed on the high side. If the interconnection transformer is primary wye grounded – secondary wye grounded, the CTs can be installed on either high or low side, provided the CTs sense the current contribution to Company EPS faults from ground sources installed on the facility. CT accuracy and burden calculations shall be provided for review by the Company.

7.6.4.2 Voltage Transformers (VT) and Connections

Voltage sensing is required on all three phases on the utility side of the interrupting device. VTs for voltage sensing shall be configured wye-grounded (Yg-Yg). Voltage measurements shall have no more than 2% error under the expected ambient temperature range (-10°C (14°F) to +45°C (113°F)) and no higher than 4% error under all operating temperatures (-40°C (-40°F) to +65°C (149°F)). If the secondary voltages can be used to detect voltage depressions for faults that occur on the Utility EPS, and the secondary voltage is within the relay's acceptable operating range, VTs may not be required. The use of Yg-Broken Delta VTs will be considered by the Company on a case-by-case basis.

7.6.5 Protective Relay and Trip Circuit Hard-Wire Requirements

Unless authorized otherwise by the Company, protective relays shall be hardwired to the device they are tripping. Further, interposing computer-based or programmable logic controllers, auxiliary modules, or the like are not permitted in the trip control scheme between the relay and the device being tripped. Trip circuits shall not be fused.

The use of interposing relays is subject to approval by the Company. Interposing relays, if proposed, shall be utility grade, and the tripping scheme shall be fail-safe.

Meter selector switches shall not be connected into the secondary circuits of current transformers used with protective relays specified by the Company.

Generator protective relays shall be located no greater than 30 feet from the device in which they control.

7.6.6 Protective Relay Test Switch Requirements

Microprocessor and non-draw out relays, including relay function 86 shall have ABB FT-1, or equivalent, test switches isolating all inputs and outputs of the relay. All test switches shall be labeled for the associated relay functions.

- **AC Inputs:** Each relay shall have its own AC test switch. DC inputs or outputs are not permitted on AC test switches.
- **DC Inputs and Outputs:**
 - For relays designated by the Company as necessary to protect the Company's Distribution EPS, it is required that each individual relay have its own DC test switch that isolates the positive and negative DC for each input and output.
 - For relays required to protect the Customer's equipment, it is required that each relay have its own DC test switch for inputs and outputs. For ease of maintenance testing and troubleshooting, it is required to isolate the positive and negative DC of the input and output.
- Groups of relays that protect the same piece of equipment, such as a transformer or a feeder, may share a DC test switch under the following conditions:
 - The individual blades of the test switch shall be grouped by relay.
 - A permanent label shall be affixed to the relay panel identifying the use of each blade.

Exception: Where the relay inputs are supplied by a control cable (such as a some recloser installations) and the relay test set uses a control cable that inputs to the same port in the recloser control enclosure, test switches may not be required.

7.6.7 Voltage Relay Devices

Voltage relays shall be frequency compensated to provide a uniform response in the range of 40 to 70 Hz. and meet IEEE 1547 requirements including capability for under/over voltage ride through. See Table 7.6.11.1-1 below for default voltage relay settings.

7.6.8 Frequency Relay Devices

Over and Under Frequency relays shall meet IEEE 1547 requirements including capability for under frequency ride through. The under-frequency trip setting shall not be higher than 58.9 Hz, as to not conflict with the under frequency load shedding schemes on the Company's EPS. For adjustable under frequency settings, the chosen setting shall not fall within the prohibited region of NERC PRC-006-220. See Table 7.6.11.1-1 below for default frequency relay settings.

7.6.9 Synchronizing Devices

The Customer shall designate one or more synchronizing devices that employ a synchronizing protection element (25) such as motorized breakers, contactor/breaker combinations, or a fused contactor (if mutually agreeable) to be used to connect the DER facility's generator to the Company's EPS. This synchronizing device could be a device other than the interconnection interrupting device and shall be utility grade. The synchronizing device shall be capable of interrupting the current produced when the DER facility is connected out of phase with the Company's EPS. Synchronism check relay functions are required at all breakers through which the generation will be synchronized with the utility source. This includes any breakers where any

part of the Customer’s DER facility will island and then synchronize back to the Company’s EPS.

7.6.10 Overcurrent Relays

Overcurrent protection is required to detect faults on the Company’s EPS, as well as faults on the Customer system that cause overcurrent conditions on the Company EPS. Overcurrent elements are required for both phase and ground in accordance with 7.6.3. Where a voltage controlled phase element (51C) is required, the relay shall utilize voltage sensing via the Yg-Yg VTs specified in section 7.6.4.2

7.6.11 Utility Grade Relay and Protective Device Settings and Verification

7.6.11.1 Default Voltage and Frequency Set Points for All Types of Energy Resources

Unless otherwise specified by the Company, the default settings for voltage and frequency trip elements are required to have setting ranges according to the following table 7.6.11.1-1 and the final time delay settings shall be approved by the Company:

Table 7.6.11.1-1 Utility Grade Relay and Parallel Generation Default Voltage & Frequency Set Points

DEVICE	PICKUP RANGE (Default set points in bold)	DEFAULT CLEARING TIME (sec)
Under Frequency (81U)	\leq 56.5 Hz	0.16
Under Frequency (81U)	\leq 58.5 Hz	300
Over Frequency (81O)	61.2 Hz \leq f <62.0Hz	300
Over Frequency (81O)	\geq 62.0 Hz	0.16
Under Voltage (27)	\leq 50% of Nominal	1.1
Under Voltage (27)	50% <V \leq 88% of Nominal	2
Over Voltage (59)	110% \leq V < 120% of Nominal	2
Over Voltage (59)	\geq 120% of Nominal	0.16

Settings other than the default, within the settings ranges in IEEE 1547, may be acceptable on a case-by-case basis and are subject to review and approval by the Company. DER facilities with Direct Transfer Trip installed may be required to have wider than the default settings to comply with ride through requirements. Note that consistent with IEEE 1547, the pickups are exact set points and the time delays are maximum total clearing times (including relay and device interruption time). The above default voltage and frequency trip settings are consistent with the National Grid Source Requirements Document ([National Grid SRD](#)) for DER.

7.6.11.2 Synchronism Check Setting Requirements for all types of Generation

Unless otherwise specified by the Company, the default settings for utility-grade synchronism check elements are required to have settings according to the following table 7.6.11.2-1 and the final settings shall be approved by the Company:

Table 7.6.11.2-1 Relay Settings to Parallel with the Company EPS

Generator Size (kVA)	Max. Frequency Difference (Δ f, Hz)	Max. Voltage Difference (Δ V, %)	Max. Phase Angle Difference (Δ Φ , degrees)
0-500	0.3	10	20
>500 – 1,500	0.2	5	15
>1,500 – 10,000	0.1	3	10

7.6.11.3 Company-designated Relays and Customer Settings

- 1) The Company will review the Customer’s settings and their calibration and test results of those relays that the Company designates as being required to satisfy the Company protection practices. In addition, the Company may require the relaying summary and logic diagrams depending on the complexity of the installation.

- 2) Any relay setting specified by the Company shall not be changed or modified at any time without the written consent of the Company.
- 3) The Customer shall be responsible to specify the settings, calibrate, test, and maintain the balance of their equipment.

7.6.11.4 Company Verification of Relay Testing

Prior to the Witness Test, the Company requires a letter from the Customer stipulating that all Company-designated protective devices have:

- control wiring verified against the accepted design drawings, and
- the calibration test performed satisfactorily according to the relay setting document of the accepted design.

7.6.12 Unintentional Islanding Protection for DER

The Customer's DER system shall not energize a de-energized Company circuit; therefore, anti-islanding protection is required for parallel generation on the Company's distribution EPS. If the Company determines that an anti-islanding protection scheme is required to mitigate the risk of a formation of an island in addition to the generator facility's own islanding detection scheme then the Company will require direct transfer trip (DTT). The Customer may propose alternative methods of anti-islanding protection of their own generation facility, although it is the Customer's responsibility to demonstrate comprehensively the validity of such methods and the Company reserves the right to make the final determination as to which anti-islanding protection method is suitable to meet the EPS safety and reliability requirements.

Note: A Customer wishing to use a generation system as a stand-by or emergency generator shall submit details regarding an interlocking scheme, or transfer switch to prevent the energization of a de-energized Company circuit that complies with National Grid ESB 750, Section 11.

7.6.12.1 General

1. The Company may reclose at any distribution EPS segment at any time without checking for de-energized segments as normal system operations to maintain service reliability. It is important to the DER operator to be aware of this possibility as it is the responsibility of the DER operator to trip off within 2 seconds in the event the EPS utility source is not present.
2. During DER impact evaluation, when a DER on the circuit causes the Company's system protection to be unable to trip for end of line faults, appropriate measures will be taken to correct this protection gap. The Company's device setting adjustments, additional protection devices, and/or customer impedance grounding may be required.
3. The requirements outlined below in regards to unintentional islanding mitigation risks are not applicable for DER proposed to be interconnected to a Company secondary network system. The Company's network systems are not designed for and cannot accept back feed.
4. Utility interactive inverters evaluated under these requirements shall not actively regulate frequency and/or voltage or provide Var support functions. Any inverter type generation established as frequency and/or voltage regulating or Var supportive will be reviewed under section 7.6.12.4 requirements.
5. DER threshold values shall be analyzed in aggregate where multiple DER projects are supplied from a single point of connection to the EPS. Individual DER projects on subdivided or adjacent parcels may be evaluated based upon total aggregate nameplate ratings as an equivalent single point connection to the EPS.
6. For cases where the line section aggregated DER is $\leq 33\%$ of minimum load regardless of DER type mix and is connected to < 35 kV distribution EPS no additional requirements identified below shall be required.
7. For DER equipped with DTT, those DER facilities will not be factored into the 10 and 25% ratio screens identified in this bulletin.
8. Where used within this document, reclose blocking is a voltage supervised reclose permissive feature required at any mid-line automated interrupting device identified through the steps outlined. Where this feature is required, each mid-line device is also

required to be SCADA equipped through National Grid's distribution EMS cellular network.

9. A complete distribution feeder may contain multiple line sections. Depending on the aggregate DER size to load ratio, multiple line sections may require review and be screened accordingly per the steps outlined.
10. Each screen shall be repeated for each line section applicable to the proposed DER. Where DTT or reclose blocking is required based on the screens, it shall be applied at the sectionalizing device for that line section.

7.6.12.2 Islanding risk mitigation methods required

Special conditions outlined within this section are required at minimum, regardless of the screening outcomes applicable in the following sections.

1. Cases where the Company's PCC recloser is required regardless of DER type:
 - a. DER \geq 300 kW and DER > 33% minimum load and is connected to < 5 kV EPS.
 - b. DER connected to > 15 kV and < 35 kV EPS where DER > 50% onsite minimum host load.
2. Cases where additional EPS protection schemes, including but not limited to transfer tripping, may be required regardless of DER type:¹⁸
 - a. If line faults (phase and ground where applicable) cannot be cleared by DER protective device or the Company's PCC recloser.¹⁹
 - b. Unique arrangements not explicitly defined within this document at the Company's discretion.
 - c. If the DER cannot be tripped off with utility-owned devices when automated sectionalizing schemes will operate.
 - d. DER connected to > 35 kV EPS where DER > 50% onsite minimum load and the connecting line is radially supplied.
3. The Company shall be provided with access rights, whether easement or fee-owned right-of-way, of the Company's facilities on the Customer's property for the PCC recloser installation serving their DER facility. See Exhibit 6 for a typical one-line configuration of a PCC recloser primary metered overhead service.

7.6.12.3 Certified DER²⁰

1. All inverters shall have an 88% voltage trip within 2 seconds to be considered in this section.
2. Proposed DER rated \leq 50 kW
 - a. No requirements.
3. Proposed DER rated > 50 kW and < 1000 kW
 - a. Line section aggregated non-certified DER is \leq 10% of mix.
 - i. No additional requirements.
 - b. Line section aggregated non-certified DER is > 10% and \leq 25% of aggregate DER.
 - i. Sandia screening²¹ may be applicable depending on inverter models on segment.

¹⁸ While the intent of this unintentional islanding protection policy is to encourage DER installations while minimizing inhibitive impacts to the DER installation, the Company reserves the right and flexibility to enforce protective measures deemed required for the safety and reliability of the EPS.

¹⁹ Customers should be aware that >15kV class circuits typically involve more complex protection schemes, which can be more likely to require DTT due to inability to see and trip faults in an acceptable time frame, in addition to operational issues that may be present at these voltage classes (23kV and 34.5kV).

²⁰ Inverter firmware derating is not acceptable for reduction of system size to satisfy thresholds within this section.

²¹ The Sandia screens (<http://energy.sandia.gov/wp-content/gallery/uploads/SAND2012-1365-v2.pdf>) are valid only for those certified inverters that have been confirmed, in writing from the manufacturer, to meet the definition of the Sandia Frequency Shift (SFS), or Sandia Voltage Shift (SVS) as positive feedback

- ii. Company-owned PCC recloser and reclose blocking on line segment sectionalizing device required if Sandia screens not passed.
 1. Detailed risk of islanding (ROI) study may be performed at the Customer's request. If results of the detailed study show no significant risk of islanding for a period greater than 2 seconds, then the recloser and reclose blocking is waived.
- c. Line section aggregated non-certified DER is > 25% of all DER.
 - i. Company owned PCC recloser required
 - ii. Reclose blocking required on line segment sectionalizing device ²²
 1. Detailed ROI study may be performed at the Customer's request. If results of the detailed study show no significant risk of islanding for a period greater than 2 seconds, then reclose blocking is waived. Company-owned PCC recloser is waived for aggregate DER ≤ 67% of line load to generation ratio or < 500 kW.
4. Proposed DER rated DER ≥ 1000 kW
 - a. Company-owned PCC Recloser required.
 - b. Reclose blocking required on line segment sectionalizing device if line segment aggregate DER > 50% of minimum load.

7.6.12.4 Non-Certified & Voltage or Frequency Regulating Inverters, Induction & Synchronous Machines

1. Require ANSI C37.90 utility-grade protective relay with IEEE 1547 voltage and frequency tripping and restoration functions.
2. Total aggregate line section DER > 33% minimum load
 - a. DTT required.

7.7 Monitoring and Control (M&C) at DER Facility

DER ranging from 250 kW in capacity and up on radial distribution systems may require supervisory control and data acquisition (SCADA) communication for visibility to the Company's energy management system (EMS) and to incorporate the ability for the Company's system operators via EMS to remote trip the generation, or DER facility, from the Company's EPS. This visibility is essential in maintaining daily system operability and the flexibility to transfer loads and feeder segments to allow for system upgrades, repairs, seasonal loading transfers, and other normal distribution system management functions that may require a SCADA remote terminal unit (RTU) or a PCC Recloser at a DER facility.

7.7.1 For Independent Power Producer (IPP) – "Utility Connected Stand Alone" projects (DER with no load)

1. The Company generally does not require any RTU system for IPP generators, regardless of the size or voltage class.
2. For all standalone DER > 1MW in facility size, a Company-owned PCC recloser is required for monitoring & control.
3. Where available, the Company will utilize the Company-owned PCC recloser serving the DER installation to obtain Company's operational polling data.

based methods according to the report or for inverters using impedance detection with positive feedback. SFS and SVS both rely on positive feedback to work.

Positive feedback – detecting a deviation in grid parameters and acting to try to make that deviation from nominal worse. Where acting to try to make that deviation worse, the perturbations must push harder as the deviations from nominal increase. The algorithm must be able to push bi-directionally in order to be considered for this screen.

²² *Where feasible, installing a PCC recloser in front of the non-certified DER may reduce or eliminate any further requirements to the subject applicant DER.*

4. The Interconnecting Customer (IC) is advised to communicate with Independent System Operator (ISO) -New England for any telemetry requirement as ISO-NE may require real-time monitoring between ISO-NE EMS and the DER site. The IC shall refer to the ISO-NE website and ISO-NE customer service help desk for details.
5. The Company reserves the right to require the IPP customer to install an RTU at their facility for any special circumstances. One situation where an EMS-RTU may be required is where there is Distribution EPS feeder selectivity operation.

7.7.2 For Non IPP - “Behind the meter” projects (DERs with customer Load)

1. For Non IPP projects, the Company will require the Interconnecting Customer(IC) to install RTU at their facility based on the Company’s delivery voltage level and the DER size. RTUs will be required for “behind the meter” DER installations for the feeder voltage class values provided in the table below.

Table 7.7.2-1: RTU Requirements by Facility Size

Delivery Voltage Class	Non IPP Generating Capacity
5kV or below.	500 kW or greater
greater than 5kV but less than 15kV	1 MW or greater
>15kV	1.8 MW or greater

2. EMS-RTU installations may be required for DER applications not covered by the conditions above as determined by the Company on a case-by-case basis. One situation where an EMS-RTU may be required is where there is Distribution EPS feeder selectivity operation.
3. The control portion would only involve the remote trip and block closing of the Customer’s interrupting device(s) designated by the Company. The block close function will be performed by control circuitry and is subject to review by the Company for acceptance.
4. The required inputs from the RTU to the Company’s EMS shall be as follows:
 - Status of main or interconnect breaker at the point of common coupling (PCC)
 - Status of individual generator breakers
 - Control input for the “designated generator interrupting device” for trip, block close & permit close functionality
 - Three phase line current for each generator
 - Three phase line current at the PCC with the Company (when there is multiple generator breakers)
 - Three phase line-to-line voltage for each generator
 - Three phase line-to-line voltage at the PCC with the Company(when there is multiple generator breakers)
 - Output kW for each unit (+ delivered to the Company, - received)
 - Output kVAR for each unit (+ delivered to the Company, - received)
 - Total MW (+ delivered by generator, - received by generator) at the PCC
 - Total MVAR (+ delivered by generator, - received by generator) at the PCC

Exceptions to the above list may be considered by the Company on a case-by-case basis.

Note: The Company will provide an EMS-RTU point list for inputs required at the DER system.

5. When a Company EMS-RTU is specified for a parallel generation project, the Company will determine the requirements for equipment, installation, and communications media in the interconnection study for the DER system. The Customer will be responsible for all initial and recurring costs associated with communications for their RTU.

- The Interconnecting Customer (IC) is advised to communicate with Independent System Operator (ISO) -New England for any telemetry requirement as ISO-NE may require real-time monitoring between ISO-NE EMS and the DER site. The IC shall refer to the ISO-NE website and ISO-NE customer service help desk for details.

7.8 Voltage and Frequency Ride Through and Control Requirements

7.8.1 Voltage and Frequency Ride Through

Inverter-based DER shall meet the requirements of IEEE 1547 Category II and the requirements of the [National Grid SRD](#). See section 7.6.11 for corresponding voltage and frequency default trip settings in accordance with the [National Grid SRD](#).

7.8.2 Voltage and Frequency Control

- All generators shall be in compliance with the latest revision of IEEE 1547.
- Field adjustable settings shall not be changed without express written consent of the Company.
- The voltage and frequency capabilities permitted in IEEE 1547 shall be disabled by default in accordance with Table 7.8.2.3-1 unless otherwise approved by the Company.

Table 7.8.2.3-1: Default Mode Settings for Inverter-based Utility Interactive DER

Function	Default Activation State
SPF, Specified Power Factor	OFF ²³
Q(V), Volt-Var Function with Watt or Var Priority	OFF
SS, Soft-Start Ramp Rate	ON Default value: 2% of maximum current output per second
FW, Freq-Watt Function OFF	OFF

The above mode settings are in accordance with the [National Grid SRD](#). If a device does not have the above mode settings and is not within the scope of the [National Grid SRD](#), the device shall operate in unity power factor mode with any available grid support functions disabled.

7.8.3 Return to Service

The DER shall not connect or return to service following a trip (including any ground fault current sources) until detecting 5 minutes of healthy utility voltage and frequency. Detection and return to service function shall be performed by utility grade relay where utility grade relay is required. “Healthy Utility Voltage and Frequency” is defined by Table 7.8.3-1, in accordance with the Enter Service Criteria in IEEE Std. 1547-2018 section 4.10:

Table 7.8.3-1: Return to Service Parameters for DER

Utility Voltage Parameter	Default Value
Minimum Return to Service Voltage:	0.95 per unit of nominal voltage
Maximum Return to Service Voltage:	1.05 per unit of nominal voltage
Minimum Return to Service Frequency:	59.5 Hz
Maximum Return to Service Frequency:	60.5 Hz

8.0 Testing and Commissioning

- The Company reserves the right to witness the Customer’s functional testing of the required devices, i.e., trip tests.

²³ OFF and operating at unity PF. Or set to ON with unity PF.

2. All Company-designated relay functions and all synchronizing elements will be witness-tested/verified by the Company's personnel prior to energization.
3. A letter, written by the Customer or their assigned agent, indicating the protection and control scheme has been functionally tested in accordance with the Customer's submitted design as accepted by the Company, shall be completed prior to the Company's witness testing.
4. The Customer shall submit a testing and commissioning plan (TCP) to the Company for review at least 20 business days prior to the scheduled witness test. If needed, consult the Company for guidance on preparing a TCP. This activity will normally be performed as specified by Section 4.2.4 in the **RI SCDG**.
5. All required equipment test reports shall be submitted per ESB 751 prior to final TCP acceptance.
6. The TCP shall be finalized as accepted by the Company no later than five (5) business days prior to functional testing of the Company-designated protective devices.

9.0 Operating

1. The Customer's DER system shall maintain a power factor at the PCC in accordance with the **RI SCDG** between 0.90 leading or lagging (VAR or voltage support can also be considered within machine ratings) unless more strict requirements apply according to the Company's Impact or Detailed Study. Corrective equipment may be required and, if so, it will be at the Customer's expense; refer to ESB 750. It is the Company's expectation that the Customer will strive to maintain a power factor at their service point that does not adversely affect the power quality (PQ) of the Company's EPS; see ESB 750
2. The Company requires a Sequence of Operations (SOO) from the Customer. The Company also requires an operating description from the Interconnection Customer for normal, alternate, and emergency (if proposed) operations, if the Customer desires to operate in these modes and in the event of any changes to the existing procedures.
3. The Customer is responsible for performing all operating functions associated with their equipment and for maintaining all equipment under their ownership. The Customer shall arrange to have trained personnel available for the proper and safe operation of their equipment.
4. The Customer shall follow the Company's specified switching protocol upon commissioning, synchronizing, and return-to-service situations with the Company's distribution system operator; see ESB 755 for more information on Customer operating and maintenance responsibilities.
5. The Customer's service and backup service requirements from the Company's system shall be requested using the prescribed forms in the Company's Electric Tariff, R.I.P.U.C. 2130.
6. Where the Company is requested to supply demand pulse information (either analog or digital), its use is not intended for generator dispatch or control.
7. Should the Customer Facility experience unexpected tripping of their interrupting device, the Customer shall first perform their own extensive analysis of all possible causes for trips of their own system before attempting to resolve those issues through the Company.
8. The Customer shall provide relay event records upon request following a system disturbance.

10.0 Power Quality Monitoring

10.1 Power Quality Compliance Verification

If during the study a DER interconnection project is identified as having the potential to cause power quality (PQ) effects on the EPS, then PQ monitoring shall be installed by the Company or Company-accepted third party PQ testing company to verify the Customer is maintaining its power quality with and without generation. Third party PQ test methods and results may be submitted to the Company for review and acceptance. These verification tests shall include, at a minimum, the following in accordance with the Company's Electricity Tariff, R.I.P.U.C. 2130 and the limits and cost responsibilities specified in the RI SCDG:

- Check service point voltage for any discernible voltage fluctuation.
- Check service point frequency for any discernible frequency fluctuation.
- Check PCC power factor to ensure it is no less than 90% (leading or lagging).
- Check service point harmonic distortion to ensure limits specified in ESB 750 and the **RI SCDG** as applicable, are maintained. Current harmonic distortion shall not adversely affect voltage harmonic distortion, the Company Distribution EPS, or service to other customers.

10.2 Power Quality Disturbance and Mitigation

1. If disturbances on the EPS and/or to other customers are suspected to originate from a Customer with DER, PQ monitoring shall be installed to verify the Customer is maintaining their power quality in accordance with the Company's ESB 750 and the RI SCDG.
2. If it is determined that system modifications or changes are needed in order to mitigate the disturbance issue, the cost of such modifications or changes shall be borne by the Interconnection Customer.
3. If any power quality concerns as a result of the Customer's DER installation cannot be immediately corrected, the Customer will not be permitted to continue generation until such concerns are resolved to the Company's satisfaction.

10.3 Transient Overvoltage / Load rejection Overvoltage (LROV)

The DER facility shall limit its cumulative instantaneous overvoltage according to Figure 3 of IEEE Std.1547-2018 section 7.4.2.

Most inverters have a 'self-protective overvoltage' setting in the inverters that, if enabled, is capable of tripping for no higher than 1.4pu voltage in 1ms or less clearing time. This set point is one acceptable means to meet the requirements if a letter from the inverter manufacturer is provided to the Company stating that this setting (or tighter) is enabled in the inverters to be installed on the site, and the inverter voltage response adheres to the curve in IEEE 1547. The Customer shall provide a letter from the inverter manufacturer or a National Recognized Testing Laboratory (NRTL) confirming that the requirements from the standard are met. The letter shall be on the manufacturer or NRTL's letterhead and include the firmware version and serial numbers of each inverter for the installation. Test data and/or standards certification supporting these statements may also be required at the discretion of the Company.

11.0 Facility Audit

The Company reserves the right to periodically audit the Customer's generation equipment installation and service connection for compliance with the Company's requirements.

12.0 Disconnection by the Company (Isolation)

Pursuant to Section 7 in the **RI SCDG**, the Company reserves the right to have the Customer remove their generation from the Company EPS at any time upon the Company's request. Normally, such requests result from the need to facilitate maintenance, test, or repair of Company facilities. The Customer's generator disconnect switch²⁴ may be opened by the Company (i.e., isolating the Customer's generating equipment), without prior notice to the Customer, for any of the following reasons:

- System emergency operations require such action.
- Company periodic checks of Customer's interfacing equipment reveal a hazardous condition, or lack of necessary maintenance for equipment necessary to protect the Company's EPS.

²⁴ Refer to Section 7.4 regarding technical requirements for draw-out breakers over 600V and the Company's ESB 750.

- Generating equipment interferes with other customers or with the operation of the Company's EPS.
- When required protective relaying and/or tele-protection is altered, inoperable, or missing
When required special equipment necessary for operating control (e.g., telemetering/SCADA) on the Company's EPS is inoperable or missing.
- Parallel operation, other than for **RI SCDG** testing of type tested inverters, prior to Company approval to interconnect.
- Failure to make available records of verification tests and maintenance of the Customer's protective devices designated by the Company, unless otherwise specified in the **RI SCDG**.
- Situations where the area EPS is in a non-normal operating scenario and the generator has not been studied for interconnection in that specific operating scenario.

13.0 REVISION HISTORY

<u>Version</u>	<u>Date</u>	<u>Description of Revision</u>
1.0	06/01/07	Initial version of new document superseding all previous revisions of ESB 756.
1.1	07/29/11	September 2010 ESB 750 Series Errata changes, formatting, and general editing.
2.0	08/06/12	Revised and formatted incorporating technical requirements of RI PUC 2078 Nov. 2011.
3.0	08/03/17	June 2017 revised for RI PUC 2163 Feb 26 2016, IEEE 1547a amendment, and technical updates
3.1	12/15/17	October-December 2017 interim amendments to Sections 7.6.11, 7.8, and Figures 2 & 5.
3.2	02/09/18	January-February 2018 interim amendments to Sections 7.6.11, 7.6.12, and 7.8.
4.0	06/29/18	June 2018 revised for IEEE 1547-2018 and updated National Grid practices.
5.0	12/04/19	December 2019 revised for updated National Grid practices.

EXHIBITS ATTACHED

EXHIBIT 1: Company Requirements for Projects Not Eligible for the Simplified Process

These are Company items to be considered in the Customer's DER Project Schedule.

ID	Activity Description	RI SCDG § or ESB ref.
Project Definition & Conceptual Analysis Phase		
1	Customer R.I.P.U.C. 2180 Exhibit C Expedited/Standard Interconnection Application Form w/technical submittal & prelim. design received	3.2 or 3.3, Figure 1, Table 1
2	Company Preliminary Technical Assessment & cost estimate for Impact or Detailed Study	3.0, Table 2
3	Company R.I.P.U.C. 2180 Exhibit I Retail Connection Agreement executed with Customer	Exhibit I
4	Customer commits to Impact or Detailed Study and provides advance payment	5.0
Final Design Review Phase		
5	Company completes Impact or Detailed Study/Service Plan	3.2 or 3.3, Figure 1, Table 1
6	Customer commits to utility system modifications in Impact or Detailed Study/Service Plan and provides advance payment	4.0, 5.0
7	Customer's project schedule and final design & specifications received	4.0 – 8.0, ESB 750 & 752 or 753 or 754 or 758
8	Company reviews Customer's design & returns comments	4.0 – 8.0, ESB 752 or 753 or 754 or 758
Installation Progress Review Phase		
9	Customer's corrected design, test reports & settings received	4.0 – 8.0, ESB 752 or 753 or 754 or 758
10	Company reviews Customer's design & returns comments	4.0 – 8.0, ESB 752 or 753 or 754 or 758
11	Company field audit of Customer's installation progress	4.0 - 6.0
Installation Compliance Verification Phase		
12	Customer's advance notice of functional testing received	4.2.4, ESB 755
13	Electrical inspection certification approval received from municipal codes enforcement	ESB 750 & 752 or 753 or 754 or 758
14	Customer's acknowledgement of satisfactory wiring & relay calibration tests received	4.2.4, ESB 755
15	Company witness of Customer's functional testing	4.2.4, ESB 755
16	Company field audit of Customer's service connection	4.0 – 6.0, ESB 750 & 752 or 753 or 754 or 758
17	Customer resolves open items	ESB 750 & 752 or 753 or 754 or 758
Energization & Synchronization Phase		
18	Verification testing satisfied	4.2.4
19	Company's metering installation complete	8.0, ESB 750 & 752 or 753 or 754 or 758
20	Company's supply system interconnection complete	4.0, 5.0
21	Company review/acceptance of Customer's resolved open items	
22	Customer's Certificate of Completion received (and energization sequence plan for interconnections >600V)	3.2 or 3.3, ESB 755
23	Company proceeds with energization	
24	Customer is permitted to synchronize generation facility in parallel to the Company's supply	
Project Closeout Phase		
25	For interconnections >600V, remainder of Customer's protective system functional testing documented in an acknowledgement letter submitted to the Company within 10 business days after energization	ESB 755
26	Customer's as-built design drawings received within 90 days for interconnections >600V	ESB 750 § 1.7
27	Company reconciliation of project costs with Customer	When requested by Customer.

EXHIBIT 2: Reference Maps of National Grid Rhode Island Secondary Network EPS Areas

Pawtucket

https://www9.nationalgridus.com/narragansett/home/energyeff/network/Eastern/Pawtucket_Network_Feeder_10-02-12.pdf

Providence:

https://www9.nationalgridus.com/narragansett/home/energyeff/network/Eastern/Providence_Network_Feeder_10-02-12.pdf

National Grid customers in the downtown districts of Pawtucket and Providence should check the National grid websites above. **If the street location is highlighted (or near) the red line, contact the Company's Customer Energy Integration department** via E-mail addressed to Distributed.Generation@nationalgrid.com to determine if the proposed location is served in National Grid's Secondary Network area.

EXHIBIT 3: Distribution Secondary Grid Network Description

In Rhode Island, National Grid generally has two types of electrical distribution systems: radial and distribution secondary network systems. While the vast majority of customers are served from radial power systems, some customers in the downtown districts of Pawtucket and Providence in Rhode Island are served by distribution secondary network systems; see **Exhibit 2** for area maps. These systems are designed to meet the higher reliability needs, dense load levels, and limited space commonly encountered in urban areas.

A distribution secondary network system delivers electricity through a complex and integrated system of transformers and underground cables that are connected and operate in parallel. Power can flow in either direction on the secondary service delivery lines, commonly called secondary distribution lines. The loss of a single line or transformer in a secondary network system does not cause an interruption of power, unlike radial systems where there is only one line and one path for power to flow from the distribution substation to the customer's point of service. If a radial system experiences an outage, service is interrupted to the customers until repairs are completed; this is less likely to be the case in a distribution secondary network system.

In distribution secondary network systems, devices called “network protectors” are usually arranged to automatically connect its associated transformer to the network system when conditions are such that the transformer when connected will supply power to the network and to automatically disconnect the transformer from the network when power flows from the network to the transformer. The integration of DER into a distribution secondary network system may result in network protectors exceeding their original design criteria or nameplate ratings.

Example Distribution Secondary Grid Network Diagram

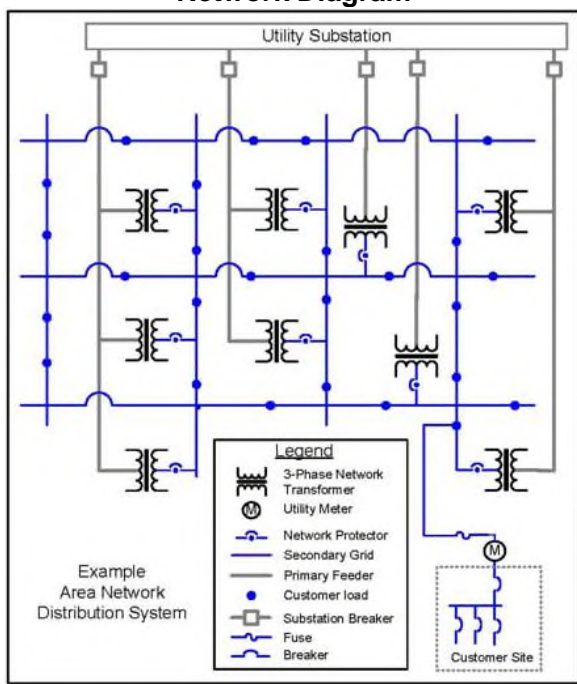

Underground secondary grid (area) network systems deliver power to each customer through a complex and integrated system of multiple transformers and underground cables that are connected and operate in parallel.

Example Distribution Secondary Spot Network Diagram

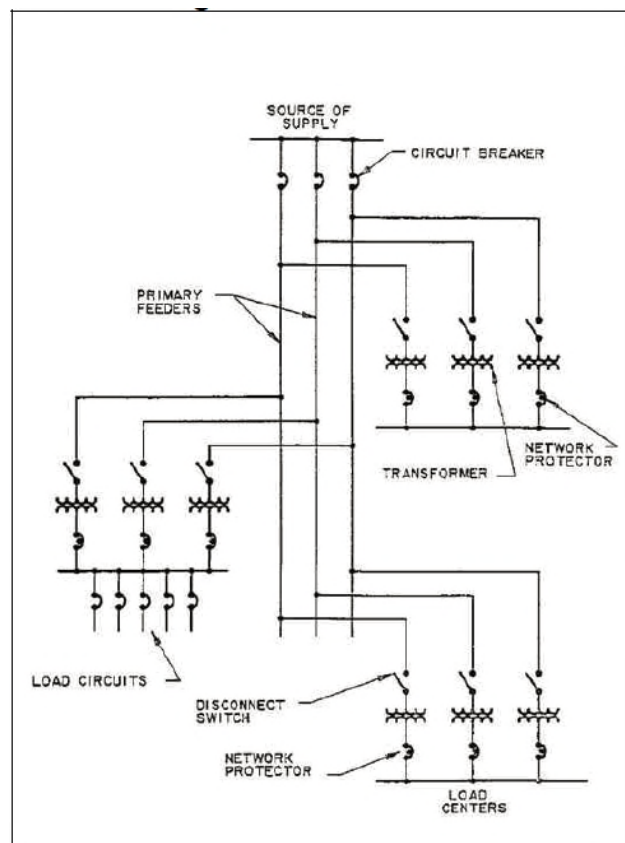

Spot networks are similar to grid (area) networks except they serve a single premise.

EXHIBIT 4: Recommended Guidelines for Residential and Commercial Single-line Diagram Submittals

Refer to **Figures 2 and 3** for typical illustration and symbology.

1. Identify the project, Company's electric service order (ESO) number, location and submitter's name and address.
2. Indicate standard and any non-standard system voltages, number of phases, and frequency of the incoming circuit. Indicate wye and delta systems; show whether grounded or ungrounded.
3. Identify cable, conductors and conduit, the type and number. The Company is interested in how the power is getting from the service point to the protective equipment.
4. Identify wiring troughs and/or junction boxes where used.
5. Use standard symbols. See **NFPA 70B** or **IEEE Standard 141** for symbols in typical electrical single-line diagram development.
6. Identify the service equipment's switch and fuse or circuit breaker as to manufacturer, type, rating, catalog number, etc. Service equipment must be able to safely interrupt the maximum available fault current from the supply; refer to **NEC** Articles 110 and 230.
7. Show billing meter trough or instrument transformers' cabinet (C.T. cabinet) in circuitry. Indicate source and load for the circuit. Refer to Section 7 in the Company's **ESB 750** for acceptable metering configurations.
8. Identify other protective devices and ratings. Include ratings in volts and amps, the interruption rating, and type and number of trip coils on circuit breakers. Also, note any special features of fuses (current limiting, dual element, etc.).
9. Identify ratios of current and potential transformers, taps to be used on multi-ratio transformers, and connection of dual ratio current transformers if used.
10. Identify any relays, if used, and their functions. Indicate which interrupting device(s) are tripped by the relay(s) used.
11. Show connections, winding configuration, and ratings of power transformers for any to be used. Show the transformer impedance and X/R ratio.
12. Indicate the connections, winding configuration and ratings of grounding transformers if any are to be used. Show the impedance and X/R ratio.
13. Identify Generator Disconnect and its ratings, the service point, and the PCC.
14. Provide catalog cut-sheets clearly identifying exact model to be installed for devices and equipment of mutual interest to the Company and of the Customer. Equipment shall be inclusive but not limited to the main service arrangement, any transformer in the circuit path between the point of common coupling and the generator, the generator interrupting device, the utility disconnect, and inverter(s) and/or relay(s).

FIGURE 1: Sample Residential Photovoltaic Distributed Generator Installation – Single Phase, Net Metered

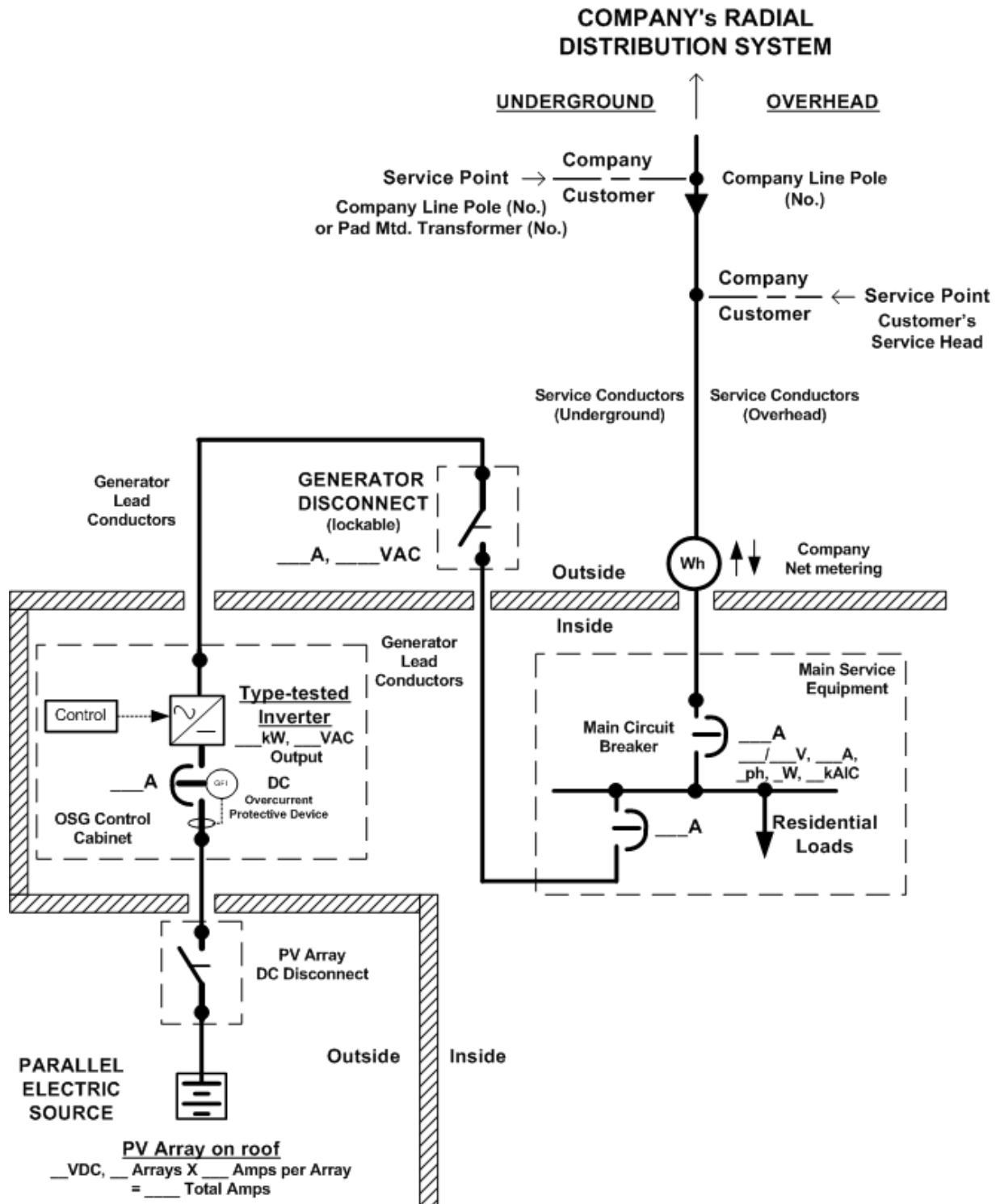

FIGURE 2: Sample Distributed Generator One-Line Diagram

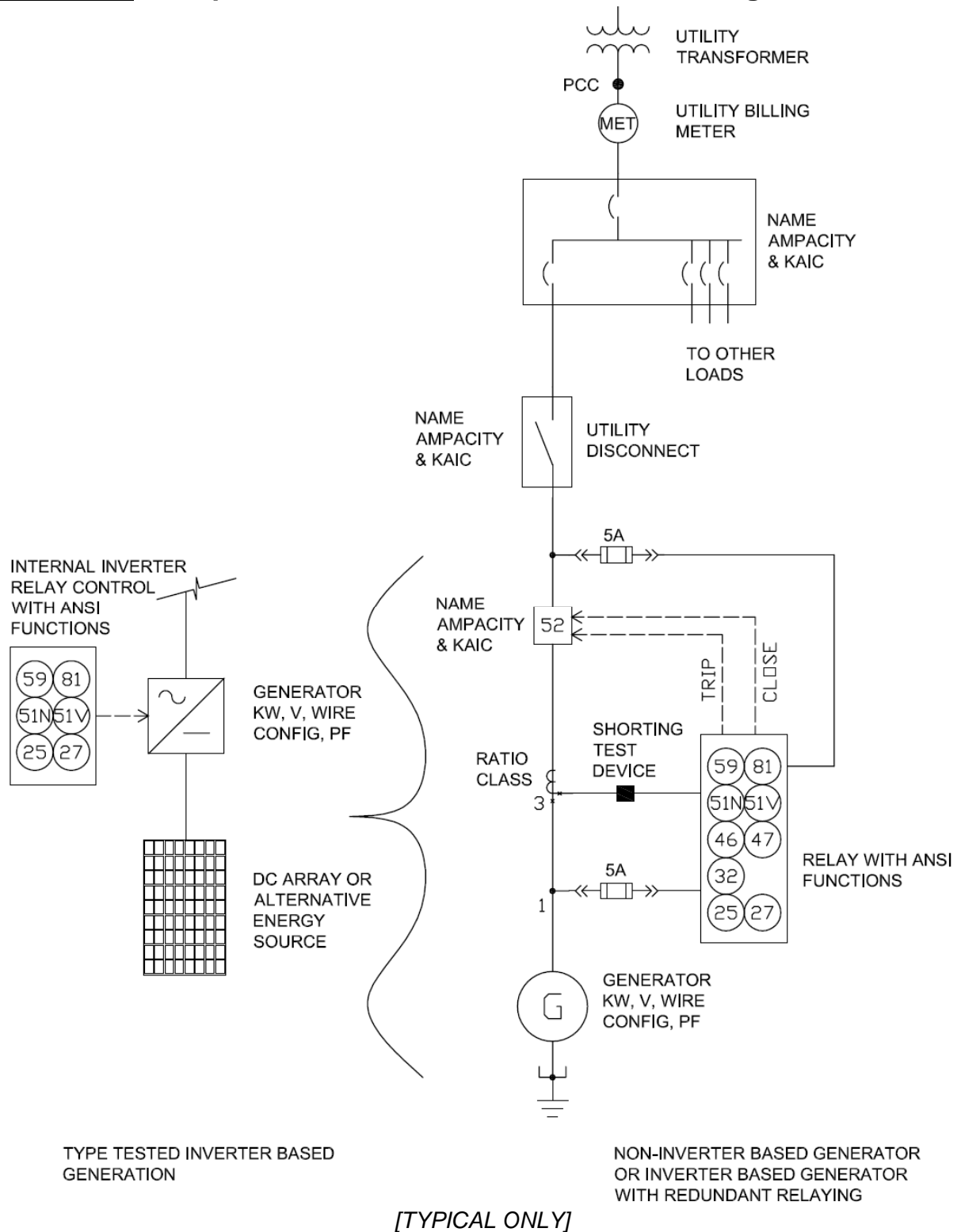

FIGURE 3: Typical Symbolology for Electrical Drawings

ELEMENTARY SWITCH DEVICES								CONTACTS AND RELAYS	
FLOW		PRESSURE		LIQUID LEVEL		TEMPERATURE		CONTACTS	
CLOSED RISING	OPENS RISING	CLOSED RISING	OPENS RISING	CLOSED RISING	OPENS RISING	CLOSED RISING	OPENS RISING	NORMALLY OPEN OR "a" CONTACT	NORMALLY CLOSED OR "b" CONTACT
LIMIT				PUSHBUTTON		RELAY COIL			
NORMALLY OPEN	NORMALLY OPEN - HELD CLOSED	NORMALLY CLOSED	NORMALLY CLOSED - HELD OPEN	NORMALLY OPEN	NORMALLY CLOSED				
ELEMENTARY FUSE DEVICES			BATTERY OR DC SOURCE			CONNECTIONS			
FUSE	SOLID LINK	IN REMOVABLE CARTRIDGE OR PULL BLOCK	GENERAL OR SINGLE CELL	MULTI CELL (COMMON)	GROUND	SHORT CIRCUIT (3-PHASE CONNECTION)	SEPARABLE CONNECTORS OR DRAW OUT FEATURE		
DISCONNECTS (UNDER 600 V)		CIRCUIT BREAKERS			TRANSFER SWITCH				
NON-FUSED DISCONNECT	FUSED DISCONNECT	GENERIC OR AIR TYPE	CB OR INTERRUPTING DEVICE (OTHER THAN AIR)		TWO POSITION	THREE POSITION			
CAPACITOR	ANTENNA	THERMAL OVERLOAD	INDICATING LIGHT * = LENS COLOR:						
			A - AMBER B - BLUE C - CLEAR G - GREEN O - ORANGE P - PURPLE R - RED W - WHITE Y - YELLOW						
TRANSFORMERS AND INSTRUMENT TRANSFORMERS									
3-PHASE, WYE		3-PHASE, DELTA					3-PHASE ZIGZAG		
GROUNDING NEUTRAL	UNGROUNDING	DELTA	CORNER GROUNDING	OPEN DELTA	OPEN DELTA CORNER GROUNDING	BROKEN DELTA	UNGROUNDING	GROUNDING	
GENERIC TWO WINDING TRANSFORMER	GENERIC THREE WINDING TRANSFORMER, TERTIARY TYPE		CURRENT TRANS. WITH POLARITY MARKS SHOWN		FUSED POTENTIAL TRANSFORMER				
			EXTERNAL TO BUSHING	BUSHING MOUNTED					
			■ OR • OR ×						

EXHIBIT 5: Recommended Guidelines for Functional Single-line Diagram Submittals

Refer to **Figures 1** and **2** for typical illustrations.

In addition to **Exhibit 4**:

15. On functional single-line diagram submittals, industry standard device numbers are necessary. Refer to the following List of Standard Device Numbers (See latest edition of **ANSI C 37.2**):

<u>Device Number</u>	<u>Function</u>
25	Synchronizing Device / Synchronism check device
27	Undervoltage Relay
32	Directional Power Relay
46	Negative Sequence Voltage
50	Instantaneous Overcurrent Relay
51	Phase Overcurrent Relay
51N	Neutral Overcurrent Relay
51G	Ground Overcurrent Relay
51V	Overcurrent Relay, voltage restraint
51C	Voltage controlled overcurrent
52	Breaker
52R	Recloser
59	Overvoltage Relay
59G	Neutral Over Voltage Relay
59N	Zero Sequence Over Voltage Relay
62	Time-delay Stopping or Opening Relay
64	Ground Protective Relay
81	Over and Under Frequency Relay
86	Lockout Relay
87	Differential Relay

FIGURE 4: Sample Functional Single-Line Diagram

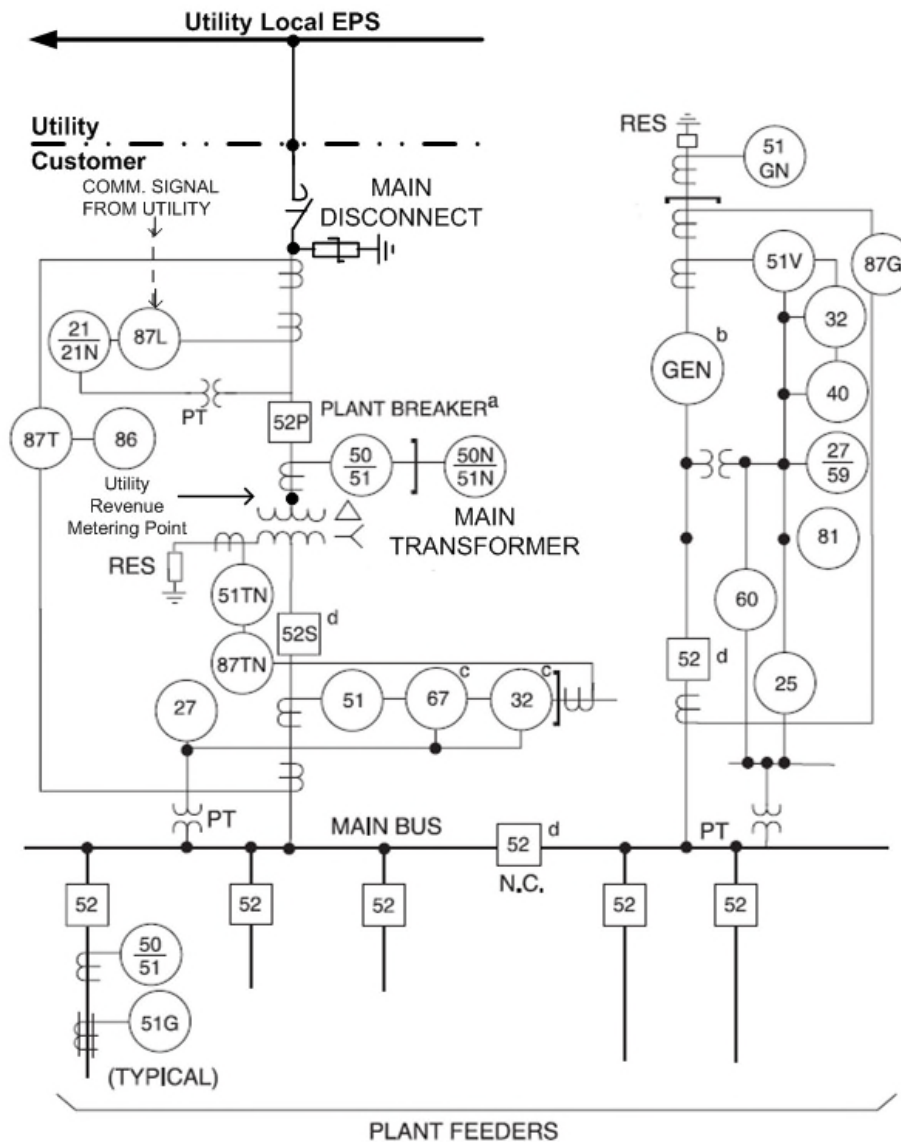

- NOTES:
- a. A fused interrupter switch may also be used instead of the breaker.
If fused interrupter is used, relaying associated with the transformer is not used.
 - b. In-plant generator for partial plant load and back-up.
 - c. Devices 67 and 32 are directional. Polarity of CTs and PTs must be verified.
 - d. Overcurrent and bus differential protection should be provided for the main, generator, and tie breakers, but protection is not shown here. See IEEE Std. C37.95 and C37.97.
- Trip function lines not shown.
See IEEE Std. 242 Buff Book "Recommended Practice for Protection and Coordination of Industrial and Commercial Power Systems" for more information.

[TYPICAL ONLY]

FIGURE 5: Typical $3V_0$ Requirements for Local EPS Ground Fault Detection

The Company requires ground fault protection on any system that can be a generation source to protect any equipment that can be parallel supplied from two sources. In the cases where the primary winding of the transformer supplying the facility is delta, a “zero-sequence” voltage or “ $3V_0$ ” scheme is required. Typically, this is implemented by installing potential transformers (PTs) on the primary system as a source to a voltage sensing relay containing a ground overvoltage device function (59N or 59G) capable of detecting the presence of a single line-to-ground fault on the Local EPS.

Notes:

1. The Company may waive this requirement depending on the restrictions of the local EPS.
2. Trip signal is shown to remove generator from Company’s EPS at the generator interrupting device. Alternatives may be proposed for Company approval for alternative arrangements.
3. Yg-Broken Delta arrangement is typical of an electromechanical relay installation while Yg-Yg is commonly applied for a microprocessor relay installation.

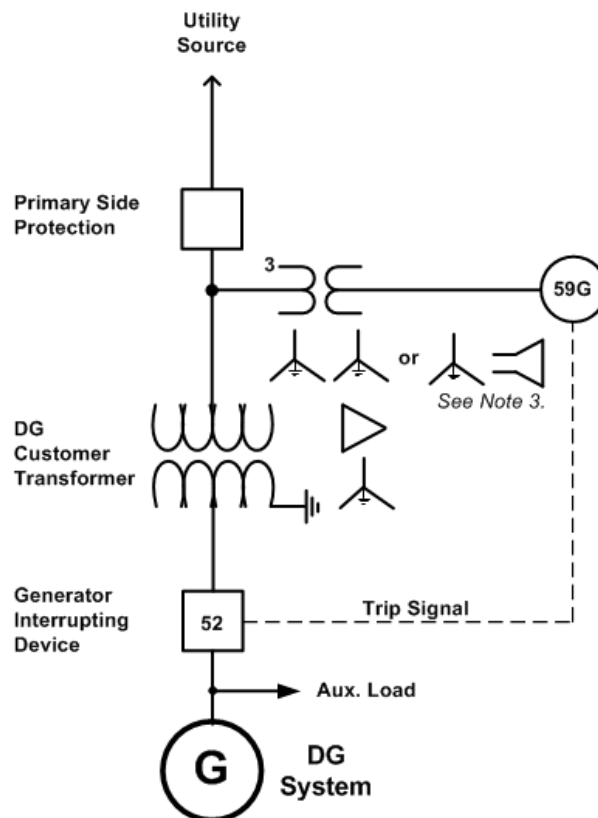

-- INFORMATION ONLY --
 -- SIMPLIFIED DIAGRAM NOT
 ALL DETAILS SHOWN --

EXHIBIT 6: Typical Overhead Primary Service Configuration in RI for Large DER Installations

The Customer will be required to install a pole to the Company's specifications on which the Company will install cross arms and dead end the Company's primary service conductors. This point will be the physical Point of Common Coupling (PCC). At this pole the Customer-owned, 3-phase gang operated, Generator Disconnect switch can be installed and connected to the Company's primary service conductors by the Customer.

All Company-owned service lateral facilities and equipment on private property will require easements. These easements will be the responsibility of the Customer to obtain in accordance with the Company's specific electric service requirements; see [ESB 750](#).

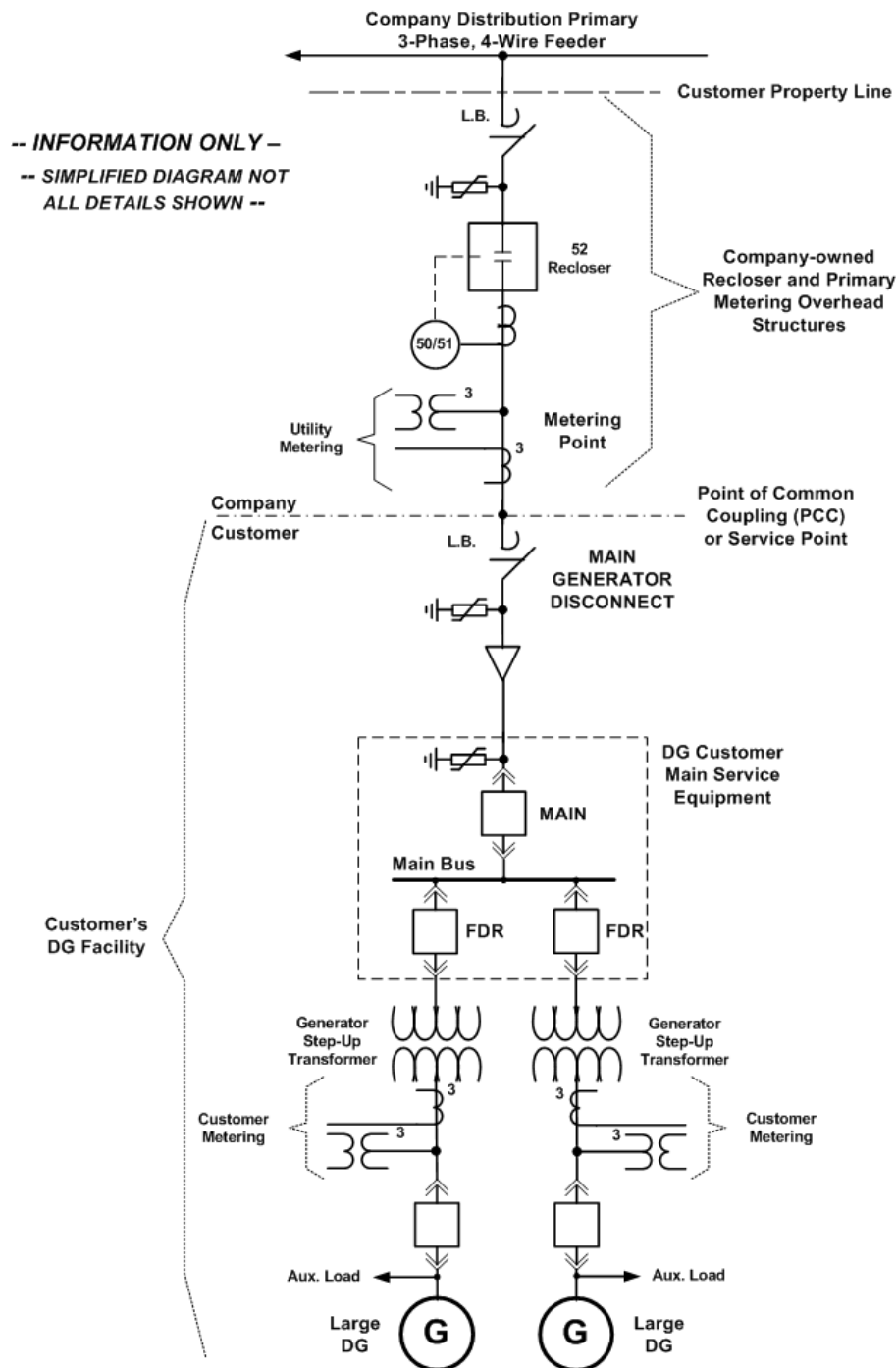

EXHIBIT 7: Net Metering Compliance Verification Checklist (Simplified Process)

Account Number: _____

Customer Name: _____
 Last First Email: _____
 Phone # _____
 Work Phone # _____

Service Address: _____
 Number Street Town/City Zip

Billing Address: _____
 Number Street Town/City Zip

Qualified Installer: _____ License # _____ Phone # _____
 Last First (if available) Cellular # _____

Address: _____ FAX # _____
 Number Street Town/City Zip Email: _____

✓ **Verify One-Line Diagram (installed equipment)**

_____ UL 1741 Certified Inverter Model _____
 _____ Software version _____
 _____ Company billing meter s/n _____ Net-meter One Meter Option: **YES** ___ **NO** ___
 _____ Inspection received? **YES** ___ Number _____ (attach copy of approval certificate)
NO ___, then stop and await inspection approval.

✓ **Verify Plot Plan (equipment's location)**

_____ "Generator Disconnect Switch" is **at agreed location**: **YES** ___ **NO** ___.
 _____ "Generator Disconnect Switch" is **labeled** as such: **YES** ___ **NO** ___.
 _____ **Label is at meter location** to identify location of Generator Disconnect: **YES** ___ **NO** ___.

✓ **Verify DG System Is Operating (producing power)**

_____ Verify "Generator Disconnect Switch" is **Open**.
 _____ Verify voltage is **zero volts** on DG side of open "Generator Disconnect Switch": **YES** ___ **NO** ___.
 _____ **Close** "Generator Disconnect Switch".
 _____ Verify DG inverter **alarms** and **voltage present** on utility side of "Generator Disconnect Switch":
YES ___ **NO** ___.

✓ **Restoration of Utility Power Test**

_____ **Open** "Generator Disconnect Switch", **pause at least 1 to 2 minutes**, then **Close** "Generator Disconnect Switch". Record time when "Generator Disconnect Switch" is closed: _____
 _____ Record time when **DG Inverter starts** producing power: _____. Is the time between the "Generator Disconnect Switch" closure and when DG Inverter permits synchronization to utility source **greater than 5 minutes**? **YES** ___ **NO** ___

✓ **24-hour Telephone Number Contact**

Name: _____ Number (____) _____

Performed by: _____ *signature*: _____ Date: _____
 Name (Customer's qualified installer)

Witnessed by: _____ *signature*: _____ Date: _____
 Name (Company witness)